

AEDM-5xxx

Quick Assembly High Resolution Three Channel Optical Encoders



Data Sheet



Description

Avago Technologies' AEDM-5xxx series encoders are high resolution and high performance three channel optical incremental encoders. These encoders emphasize on high reliability, high resolution, and easy assembly.

Each encoder contains a LED source with lens, an ASIC with integrated photo detector arrays, LED current regulation, interpolator and output driver circuitry, and a code wheel which rotates between the emitter and detector ASIC. The outputs of the AEDM-5xxx are two square waves in quadrature. In addition, a third channel offers index signal, which is a 90 electrical degree, true index pulse which is generated once for each full rotation of the code wheel. The AEDM-5xxx series utilizes a film code wheel allowing for resolutions up to 5000 CPR.

These bearing-less housed encoders may be quickly and easily mounted to a motor. For larger diameter motors, the AEDM-59xx series feature external mounting ears option.

The quadrature signals and the index pulse are accessed through five 0.025 inch square pins located on 0.1 inch centers.

Standard resolutions between 2000 and 5000 counts per revolution are presently available. Consult local Avago sales representatives for other resolutions.

Features

- Two channel quadrature output with index pulse
- High Resolution - up to 5000 CPR
- Operating temperature – 40°C to +85°C
- Quick and easy assembly
- No signal adjustment required
- Cost Effective solution
- Small size
- TTL compatible output
- Single 5V supply with $\pm 10\%$ tolerance
- External mounting ears option available for larger motors.

Note: Avago Technologies encoders are not recommended for use in safety critical applications such as. ABS braking systems, power steering, life support systems and critical care medical equipment. Please contact our sales representative if clarifications are needed.

CAUTION: It is advised that normal static precautions be taken in handling and assembly of this component to prevent damage and/or degradation which may be induced by ESD.

Absolute Maximum Ratings

Parameter	Symbol	Minimum	Maximum	Units
Storage Temperature	T_s	-40	+85	°C
Operating Temperature	T_A	-40	+85	°C
Supply Voltage	V_{CC}	-0.5	7	V
Output Voltage	V_O	-0.5	V_{CC}	V
Output Current per Channel	I_{OUT}		±5	mA
Velocity			12,000**	RPM

Note **: Velocity 12000 RPM applies to Encoder Resolution of 5000 CPR

Recommended Operating Conditions

Parameter	Symbol	Min.	Typ.	Max.	Units	Notes
Temperature	T_A	-40		+85	°C	
Supply Voltage	V_{CC}	4.5	5.0	5.5	Volt	Ripple < 100 mVp-p
Load Capacitance	C_L			100	pF	
Output Frequency	f			500	kHz	2000 – 2500 CPR
				1,000	kHz	4000 – 5000 CPR
Shaft Perpendicularity Plus Axial Displacement				± 0.15 (± 0.006)	mm (in.)	
Spatial play (including shaft eccentricity)				Ø0.40 (0.016)	mm (in.)	

Encoding Characteristics

Encoding characteristics are applicable per the Recommended Operating Conditions, unless otherwise specified. Values are for the worst case error over the full rotation.

Encoder Resolution ≥ 4000 CPR

Parameter	Symbol	Min	Typ.*	Max	Units
Pulse Width Error	ΔP		21	45	°e
Logic State Width Error	ΔS		17	45	°e
Phase Error	$\Delta\phi$		12	25	°e
Cycle Error	ΔC		36	60	°e
Index Pulse Width	P_0	65	90	115	°e

Encoder Resolution ≤ 2500 CPR

Parameter	Symbol	Min	Typ.*	Max	Units
Pulse Width Error	ΔP		20	30	°e
Logic State Width Error	ΔS		15	25	°e
Phase Error	$\Delta\phi$		10	15	°e
Cycle Error	ΔC		17	30	°e
Index Pulse Width	P_0	72	90	108	°e

* Typical values specified at $V_{CC} = 5.0V$ and 25°C and for single ended, unless otherwise stated

Electrical Characteristics

Electrical Characteristics over Recommended Operating Range

Parameter	Symbol	Min.	Typ.*	Max.	Units	Notes
Supply Current	I _{CC}		25	80	mA	No load
High Level Output Voltage	V _{OH}	2.4			V	I _{OH} = -5 mA
Low Level Output Voltage	V _{OL}			0.4	V	I _{OL} = 5 mA.
Rise Time	t _r		10		ns	C _L = 100 pF
Fall Time	t _f		10		ns	C _L = 100 pF

*Typical values specified at V_{CC} = 5.0 V and 25°C.

Mechanical Characteristics

Parameter	Symbol	Dimension	Tolerance ^[1]	Units
Shaft Diameters		Per ordering information	g6	mm (in.)
Moment of Inertia	J	0.6 (8.0 x 10 ⁻⁶)		g-cm ² (oz-in-s ²)
Required Shaft Length ^[2]		14.0 (0.55)	± 0.5 (± 0.02)	mm (in.)
Bolt Circle ^[3]	2 screw mounting	19.05 (0.750)	± 0.13 (± 0.005)	mm (in.)
	3 screw mounting	20.90 (0.823)	± 0.13 (± 0.005)	mm (in.)
	external mounting ears	46.0 (1.811)	± 0.13 (± 0.005)	mm (in.)
Mounting Screw Size ^[4]	2 screw mounting	M 2.5 or (2-56)		mm (in.)
	3 screw mounting	M 1.6 or (0-80)		mm (in.)
	external mounting ears	M 2.5 or (2-56)		mm (in.)
Encoder Base Plate Thickness		0.33 (0.130)		mm (in.)
Hub Set Screw		(2-56)		(in.)

Notes:

1. These are tolerances required of the user.
2. The AEDM-5805, 5905 provide an 8.9 mm (0.35 inch) diameter hole through the housing for longer motor shafts. See Ordering Information.
3. The recommended mounting screw torque for 2 screw and external ear mounting is 1.0 kg-cm (0.88 in-lbs). The recommended mounting screw torque for 3 screw mounting is 0.50 kg-cm (0.43 in-lbs).

Output Waveforms

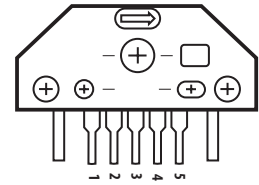
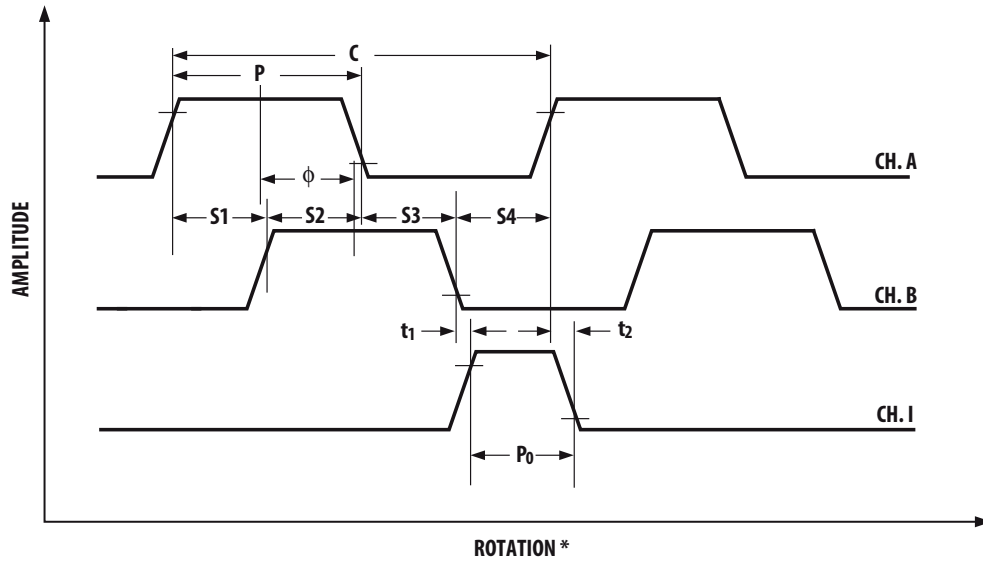

*** SPIN DIRECTION FOLLOWS ARROW MARKING ON ENCODER**

Direction of Rotation: When the codewheel rotates in the counter-clockwise direction (as viewed from the encoder end of the motor), channel A will lead channel B. If the codewheel rotates in the clockwise direction, channel B will lead channel A.

Mounting Considerations

The AEDM-5xxx Series high resolution encoders must be aligned using the aligning pins as specified in Figure 2, or using the HEDS-8910 Alignment Tool as shown in Encoder Mounting and Assembly.

The AEDM-58xx can be mounted to a motor using either the two screw or three screw mounting option as shown in Figure 1. The optional aligning pins shown in Figure 2 can be used with either mounting option

The AEDM-59xx have external mounting ears which may be used for mounting to larger motor base plates. Figure 3 shows the necessary mounting holes with optional aligning pins and motor boss.

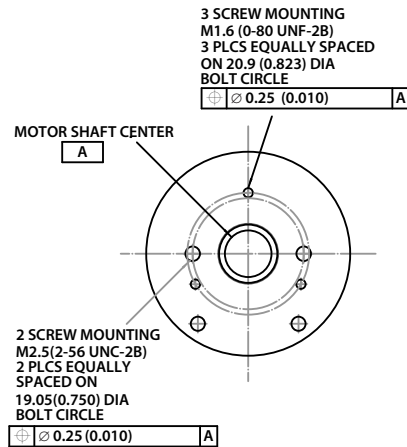

Figure 1. Mounting Holes

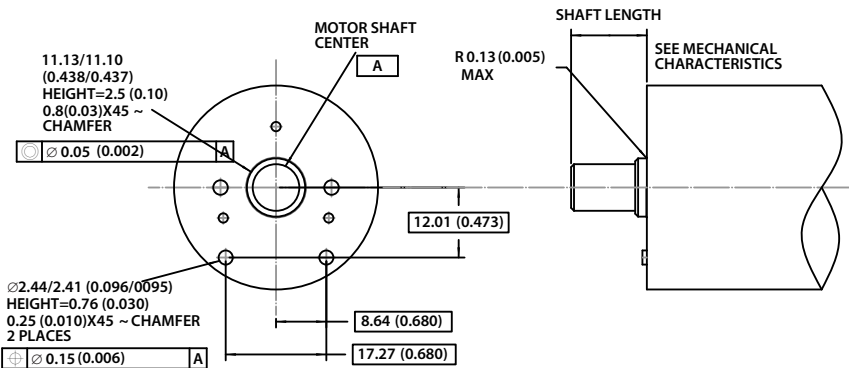

Figure 2. Optional Mounting Aids

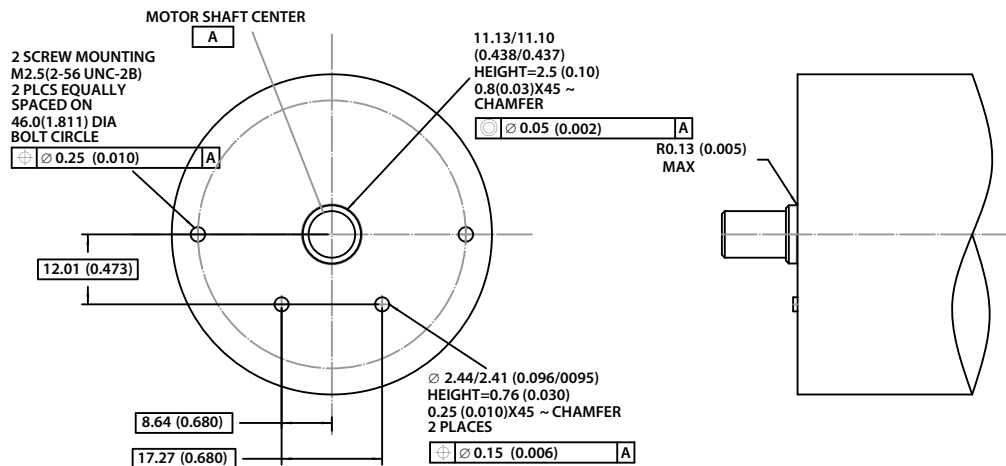

Figure 3. Mounting with external ears

Index Pulse Width (PO): The number of electrical degrees that an index output is high during one full shaft rotation. This value is nominally 90°e or 1/4 cycle.

Encoder Mounting and Assembly

Assembly process for AEDM-58xx and AEDM-59xx

1. Slide the alignment tool onto the motor shaft. With alignment tool in place, mount encoder baseplate onto motor as shown above. Ensure that the holes in the baseplate align with the mounting holes in the motor body. Inset and tighten mounting screws* and remove alignment tool.
2. Snap encoder body onto base plate locking all 4 snaps.

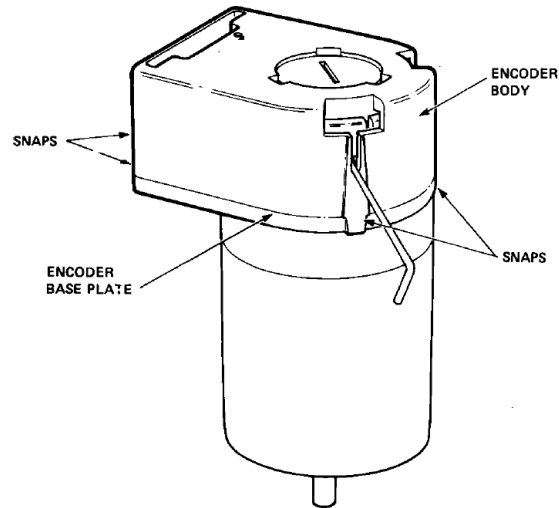
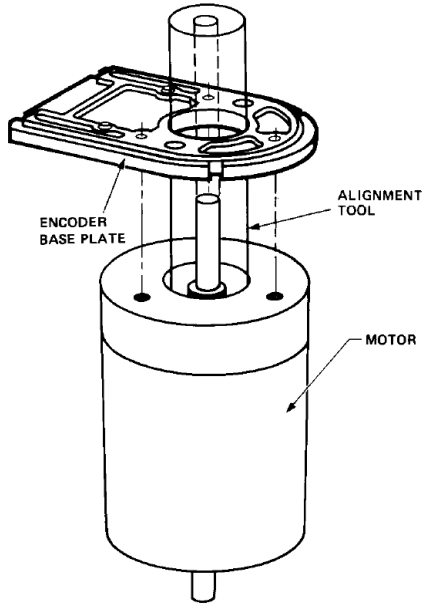

- 3a. Inset the hex wrench into the body of the encoder. Ensure that it is properly seated into the code wheel hub set screws. Then apply a downward force on the end of the hex wrench. This sets the code wheel gap by levering the code wheel hub to its upper position.
- 3b. While continuing to apply a downward force, rotate the hex wrench in the clockwise direction until the hub set screw is tight** against the motor shaft. The hub set screw attaches the code wheel to the motor's shaft.
- 3c. Remove the hex wrench by pulling it straight out of the encoder body.

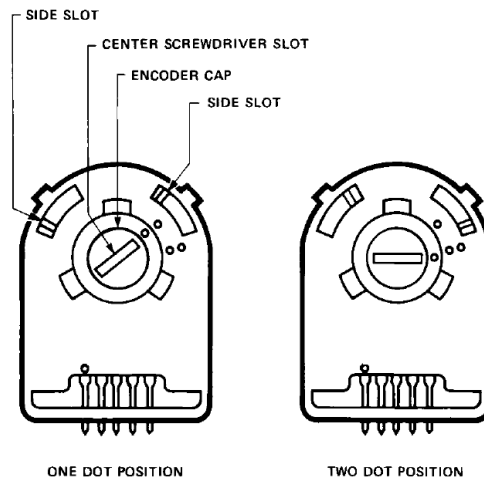
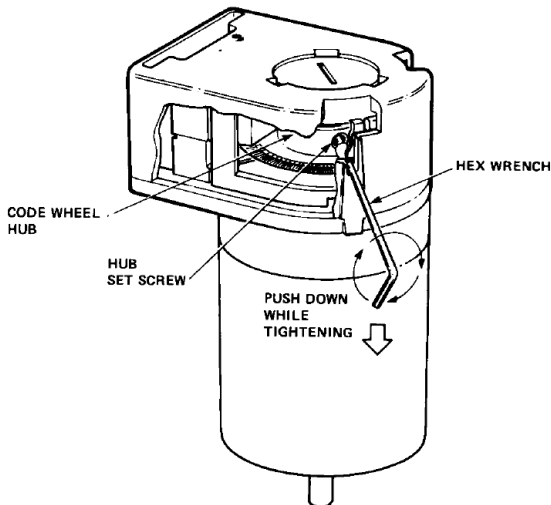

4. Use the center screwdriver slot, or either of the two side slots, to rotate the encoder cap dot clockwise from the one dot position to the two dot position. Do not rotate the encoder cap counterclockwise beyond the one dot position. The encoder is ready for use!

* Adhesive should be applied to the screw-baseplate interface to prevent screws loosening due to the effect of vibration and high temperature on plastic. High temperature rated adhesive such as HERNON Ultra 317 is recommended.

** The recommended torque to tighten the setscrew is 15-18 ozf.inch.

Connectors

HEDS-890x connector dimensions

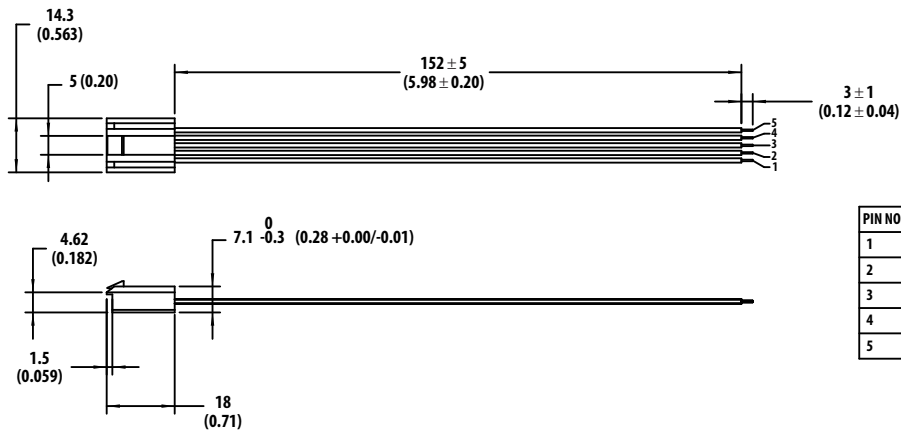

Figure 4. HEDS-8902 and HEDS-8903 Connectors

Connectors

Manufacturer	Part Number
AMP	103686-4
	640442-5
Avago *	HEDS-8902 (2 ch.) with 4-wire leads
	HEDS-8903 (3 ch.) with 5-wire leads
Molex	2695 series with 2759 series term.

* Avago connectors are designed to mechanically lock into the AEDM-5XXX Series.