

AEDR-8600

Two-Channel Reflective Incremental Encoder

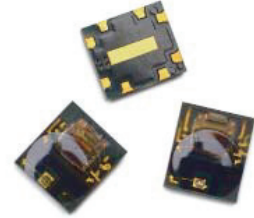

Description

The Broadcom[®] AEDR-8600 is a small two-channel optical encoder with digital outputs. It uses reflective technology for motion control purposes.

The AEDR-8600 offers two-channel quadrature digital outputs. Being TTL compatible, the outputs of the AEDR-8600 encoder can be interfaced directly with most of the signal processing circuitries. Therefore, the encoder provides easy integration and flexible design-in into existing systems.

The AEDR-8600 encoder is designed to operate over -20°C to $+85^{\circ}\text{C}$ temperature range and is suitable for commercial and industrial end applications.

The encoder houses an LED light source and photo-detecting circuitry in a single package. The small size of 3.95 mm (L) x 3.4 mm (W) x 0.9562 mm (H) allows it to be used in a wide range of miniature commercial applications, where size and space are primary concerns.

Features

- Two-channel quadrature digital outputs for direction sensing
- Surface-mount leadless package: 3.95 mm (L) x 3.4 mm (W) x 0.9562 mm (H)
- Built-in interpolator with 1x, 2x, and 4x, selectable via external pinouts
- TTL compatible
- Single 5.0V supply
- -20°C to $+85^{\circ}\text{C}$ absolute operating temperature
- Encoding resolution: 294 LPI (lines per in.) to 304 LPI

Applications

- Ideal for high-volume applications
- Closed-loop stepper motors
- Miniature motors
- Printers
- Copiers
- Card readers
- Scanners
- Projectors
- Consumer and industrial product applications

ATTENTION: This product is not specifically designed or manufactured for use in any specific device. Customers are solely responsible for determining the suitability of this product for its intended application and solely liable for all loss, damage, expense or liability in connection with such use.

Product Overview

Figure 1: Signal Processing Circuitry

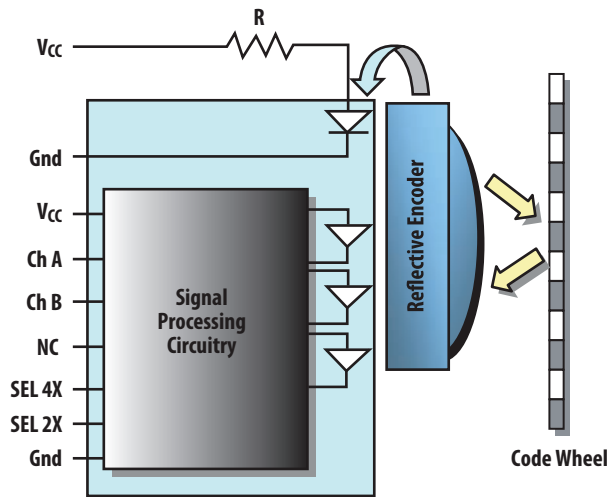

Note: Drawing not to scale.

Output Waveform

Figure 2: Sample of Output Waveforms

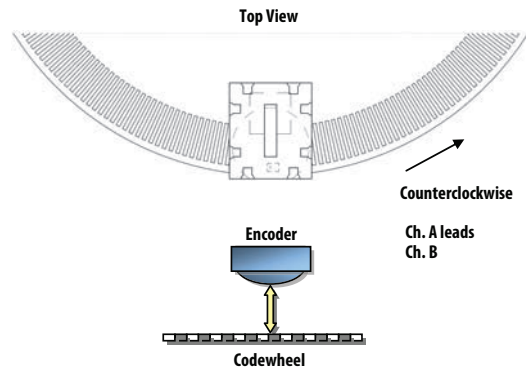
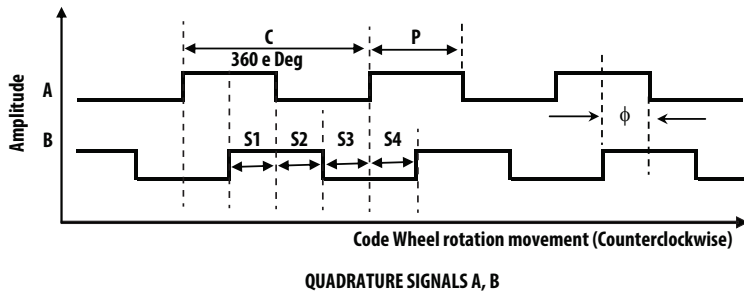

Note: Drawing not to scale.

Absolute Maximum Ratings

Parameter	Symbol	Value
Storage Temperature	T_S	-40°C to 125°C
Operating Temperature	T_A	-40°C to 115°C
Supply Voltage	V_{CC}	7V
Output Voltage	V_O	V_{CC}

NOTE:

1. Proper operation of the encoder cannot be guaranteed if the maximum ratings are exceeded.
2. Exposure to extreme light intensity (such as from flashbulbs or spotlights) can cause permanent damage to the device.

CAUTION! Take anti-static discharge precautions when handling the encoder in order to avoid damage, degradation, or both, induced by ESD.

Recommended Operating Conditions (Code Wheel of R_{OP} at 11.38 mm)

Parameter	Sym.	Min.	Typ.	Max.	Unit	Notes
Operating Temperature	T_A	-20	25	85	°C	
Supply Voltage	V_{CC}	4.5	5	5.5	V	Ripple < 100 mV _{p-p}
LED Current	I_{LED}	—	15	—	mA	Use an 180Ω(±1%) LED current-limiting resistor
Count Frequency ^a	F	—	55	—	kHz	1x interpolation factor
Radial Misalignment	E_R	—	—	±0.2	mm	
Tangential Misalignment	E_T	—	—	±0.2	mm	
Code Wheel Gap	G	0.5	1.0	1.25	mm	1.0 mm nominal gap

a. Count frequency = velocity (rpm) x CPR / 60.

Encoder Pinout

Figure 3: Pin Configuration, Top View

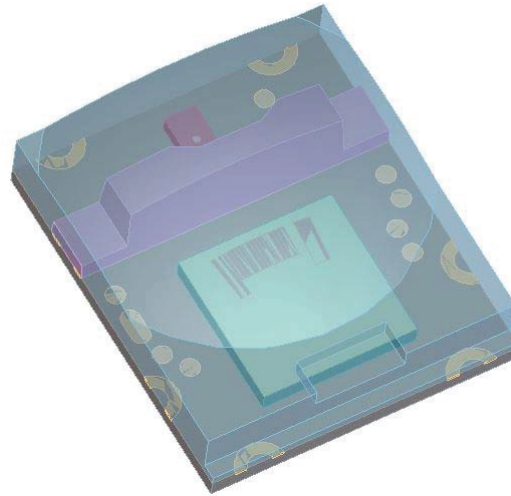
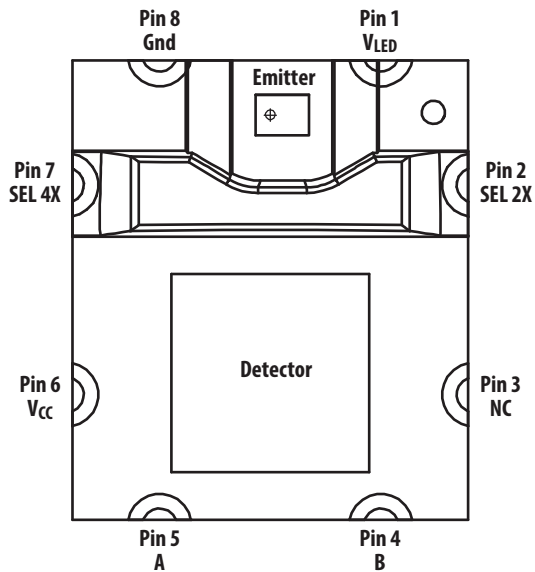

AEDR-8600 Built-in Interpolation

Pin (Interpolation)		Interpolation Factor	CPR ($R_{OP} = 11.38\text{mm}$)	Count Frequency
SEL4X	SEL2X			
Low ^a	Low	1X	828	55 kHz
Low	High	2X	1656	110 kHz
High ^b	Low	4X	3312	220 kHz
High	High	Factory use	—	—

a. Low logic level

b. High logic level

The digital interpolation factor above is used with the following equations to cater to various rotational speed (RPM) and count per revolution (CPR).

$$\text{RPM} = (\text{Count Frequency} \times 60) / \text{CPR}$$

The CPR (at 1X interpolation) is based on the following equation, which is dependent on radius of operation (R_{OP}).

$$\text{CPR} = \text{LPI} \times 2\pi \times R_{OP} \text{ (inch)} \text{ or } \text{CPR} = \text{LPmm} \times 2\pi \times R_{OP} \text{ (mm)}$$

Digital Encoder Characteristics (Code Wheel of R_{OP} at 11.38 mm)

Encoding characteristics over the recommended operating condition and mounting conditions.

Parameter	Symbol	Typical ^a			Unit
		1X	2X	4X	
Interpolation Factor					
Cycle Error	ΔC	18	22	36	°e
Pulse Width Error	ΔP	15	20	30	°e
Phase Error	$\Delta \phi$	9	15	18	°e
State Error	ΔS	10	15	25	°e

a. Typical values represent the average value of the encoder performance at typical mounting alignment, whereas the maximum values represent the encoder performance across the range of recommended mounting tolerance.

Electrical Characteristics

Characteristics over recommended operating conditions at 25°C.

Parameter	Symbol	Min.	Typ.	Max.	Unit	Notes
High Level Output Voltage	V_{OH}	2.4	—	—	V	$I_{OH} = -1.5$ mA
Low Level Output Voltage	V_{OL}	—	—	0.4	V	$I_{OH} = +1.5$ mA
Output Current Per Channel, I_{out}	I_O	—	—	1.5	mA	
Rise Time	t_r	—	<100	—	ns	CL = 25 pF
Fall Time	t_f	—	<100	—	ns	RL = 2.7 kΩ

LED Current-Limiting Resistor

A resistor to limit the current to the LED is required. Use a 180Ω ($\pm 1\%$) resistor. Place it in series between the 5V supply and pin VLED of the encoder. This will result in an LED current of approximately 15 mA for optimal encoder performance.

Figure 4: Resistor Placement

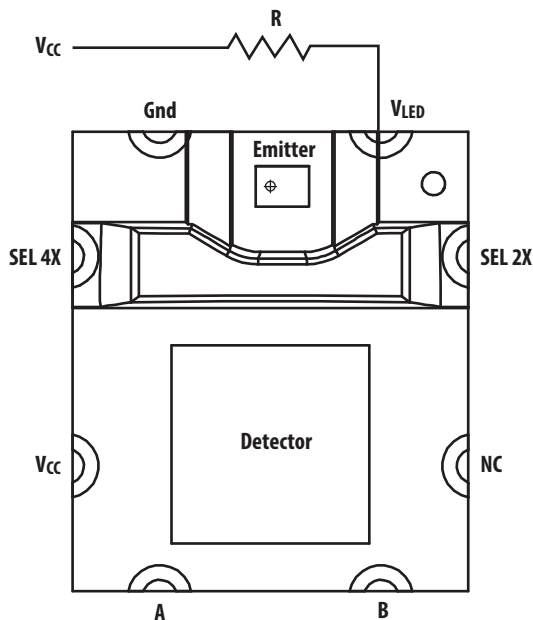

Code Wheel Design Example

The following example demonstrates a code wheel design for a R_{OP} of 11.38 mm at 828 CPR for a typical two-channel encoder.

Figure 5: Code Wheel Pattern for a Two-Channel Encoder

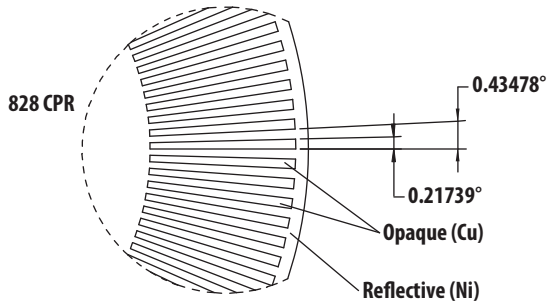

Recommended Code Wheel Characteristics

Parameter	Symbol	Min.	Max.	Unit	Notes
Window/Bar Ratio	W_W/W_b	0.9	1.1	—	
Window/Bar Length	L_W	1.80 (0.071)	—	mm (in.)	
Specular Reflectance	R_f	60	—	mA	Reflective area ^a
		—	10		Non-reflective area
Line Density	LPI	294	304	lines per in.	Recommended LPI = 294
	LPmm	11.575	11.969	lines per mm	$LPmm = CPR / [2\pi \cdot R_{OP}(mm)]$

a. Measurements from TMA μ Scan meter.

NOTE: The LED used in AEDR-8600 has a typical peak wavelength of 630 nm.

Package Outline Drawing

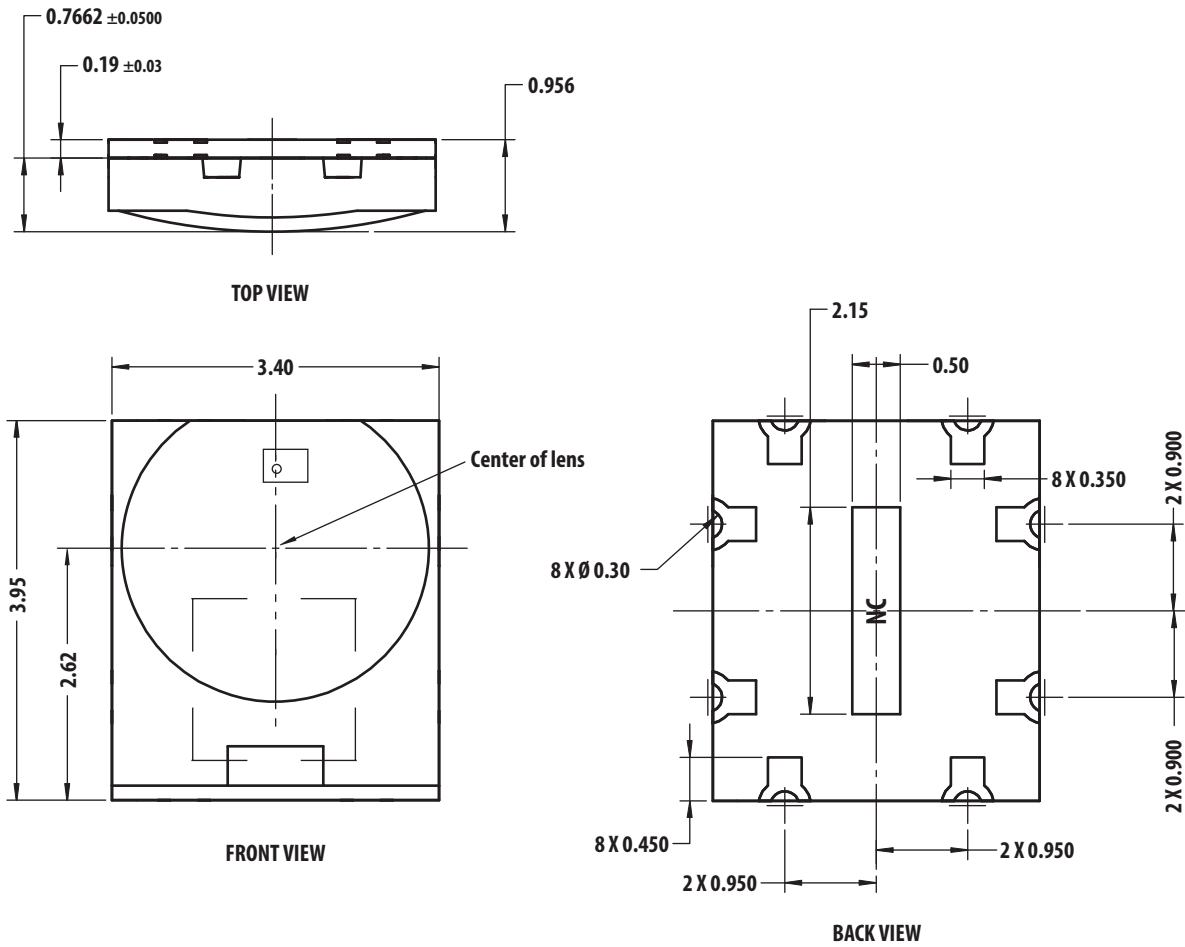

NOTE:

1. All dimensions are in millimeters (mm).
2. Unless otherwise specified, tolerance is x.xx ± 0.15 mm.

Encoder Placement Orientation, Position, and Direction of Movement

The AEDR-8600 is designed with both the emitter and detector IC placed in parallel to the code wheel window/bar orientation. The encoder package is mounted on top facing down onto the code wheel. When properly aligned, the detector side will be closer to the center of the code wheel than the emitter.

The optical center of the encoder package must be aligned with the operating radius of the code wheel's R_{OP} , or rather the center point of L_W (0.5 of the Length of Window). L_W is to be 1.8 mm or greater.

The optimal gap setting recommended is from 0.5 mm to 1.25 mm.

Channel A leads Channel B when the code wheel rotates counterclockwise, and Channel B leads Channel A when the code wheel rotates clockwise.

Figure 6: Placement Orientation of The Encoder on the Code Wheel, Top View

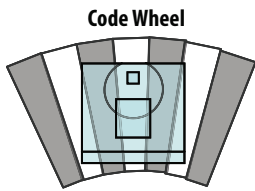

Figure 7: Optimal Code Wheel Encoder Gap, Side View

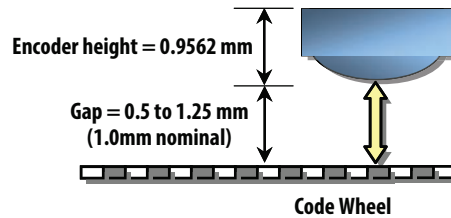
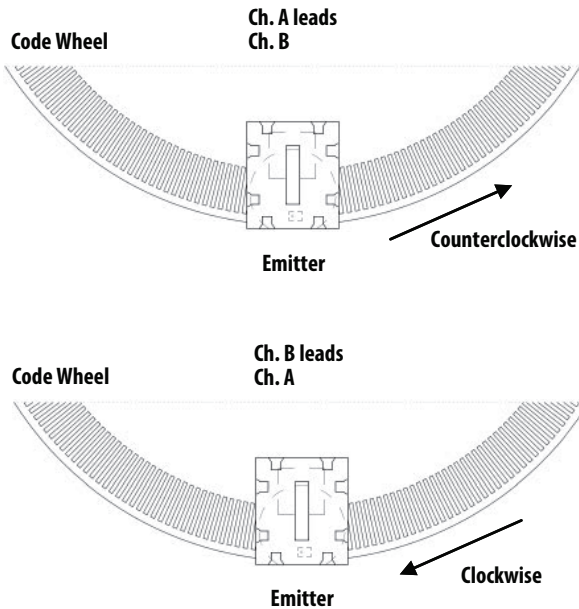

Figure 8: Placement Orientation of The Encoder on the Code Wheel, Top View



NOTE: Drawings are not to scale.

Moisture Sensitivity Level

The AEDR-8600 package is qualified to moisture sensitive level 3 (MSL 3). Precaution is required to handle this moisture sensitive product to ensure the reliability of the product.

Storage before use:

- Unopened moisture barrier bag (MBB) can be stored at $<40^{\circ}\text{C}/90\% \text{ RH}$ for 12 months.
- Open the MBB just prior to assembly.

Control after opening the MBB:

- The encoder that will be subjected to SMT reflow must be mounted within 168 hours of exposure to factory conditions of $<30^{\circ}\text{C}/60\% \text{ RH}$.

Control for unfinished reel:

- Store a sealed MBB with desiccant or desiccators at $<5\% \text{ RH}$.

Baking is required if:

- The humidity indicator card (HIC) is $>10\%$ when read at $23^{\circ}\text{C} \pm 5^{\circ}\text{C}$.
- The encoder floor life exceeded 168 hours after opening the moisture barrier bag.

Recommended baking condition:

- $60^{\circ}\text{C} \pm 5^{\circ}\text{C}$ for 20 hours (tape and reel) or $125^{\circ}\text{C} \pm 5^{\circ}\text{C}$ for 5 hours (loose units).

Figure 9: Recommended Land Pattern for AEDR-8600

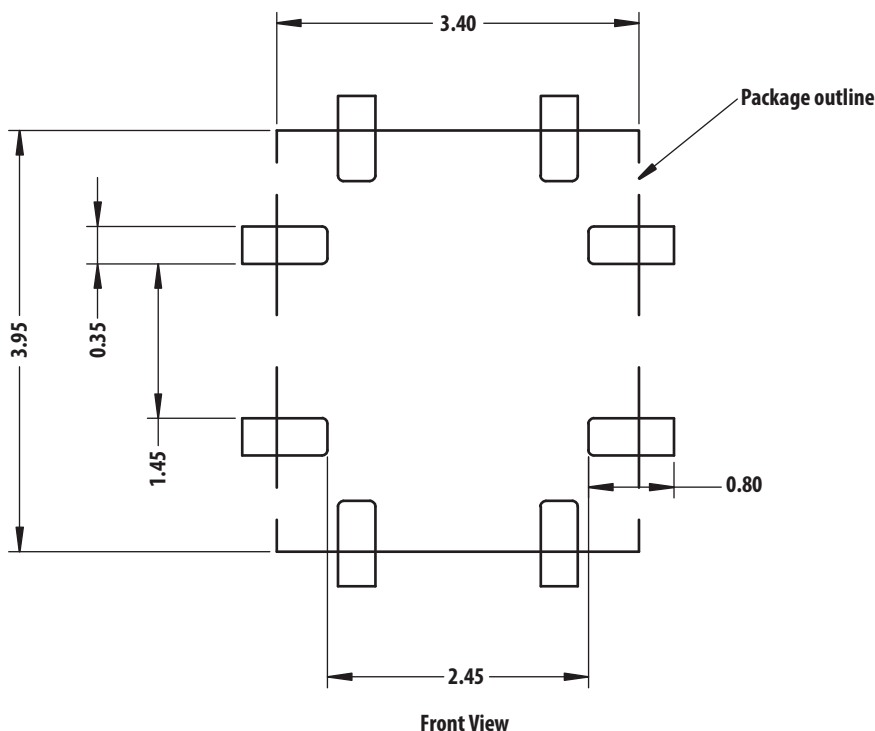

Lead-Free Reflow Soldering

Figure 10: Typical Lead-Free Solder Reflow Profile

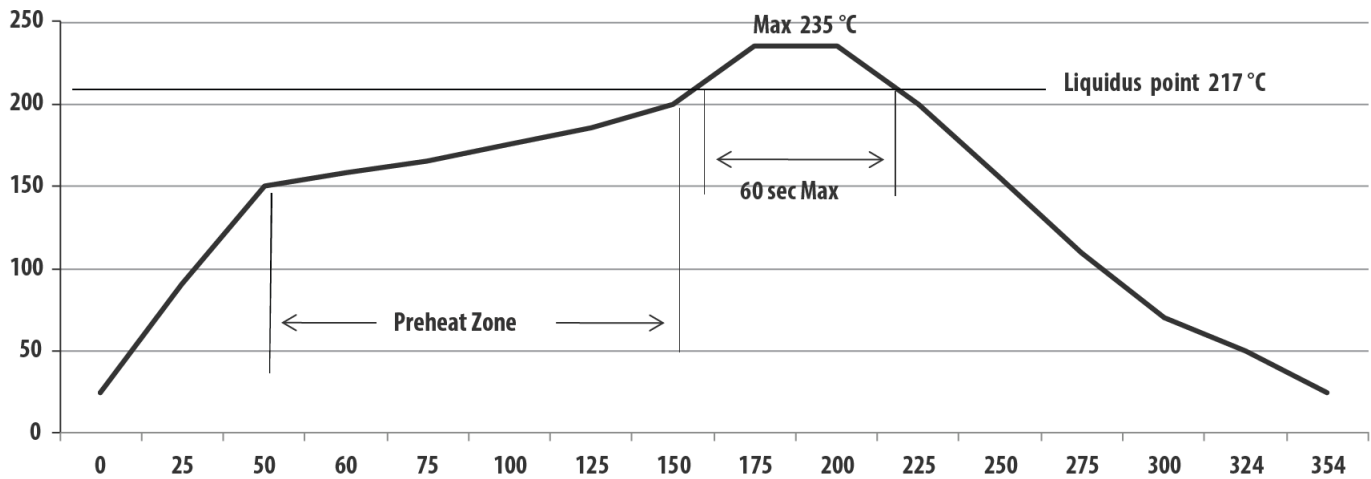

Average Ramp Up Rate	3°C per second
Average Ramp Down Rate	6°C per second
Preheat Temperature	150°C to 200°C
Preheat Time	60 seconds to 100 seconds
Time Maintain Above 217°C	40 seconds to 60 seconds
Peak Temperature	235°C
Time Within 5°C of Peak Temperature	20 seconds to 30 seconds

Figure 11: Thermocouple Placement

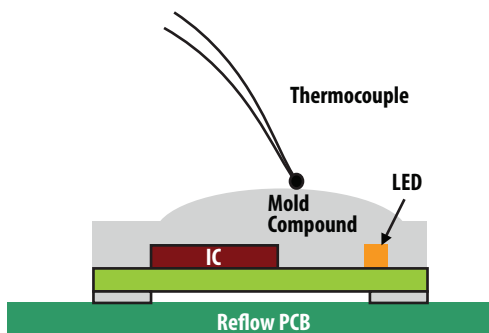

NOTE:

1. Reflow with a peak temperature >235°C may cause damage to the component.
2. Due to treatment of high temperature, this clear compound may turn yellow after IR reflow.
3. The profile shown here is the actual readings from the thermocouple attached to AEDR-8600 as shown in [Figure 11](#) on the reflow board PCB.

Tape and Reel Information

Figure 12: AEDR-8600 Carrier Tape Dimensions

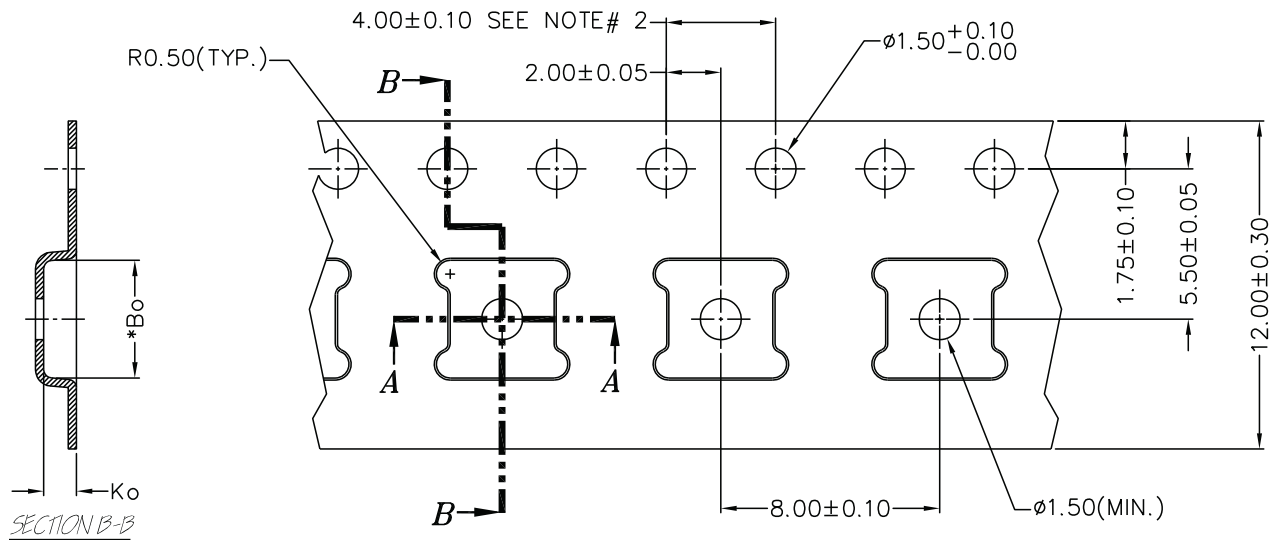

NOTES:—

1. * Ao & Bo measured at 0.3mm above base of pocket.
2. 10 pitches cumulative tol. ±0.2mm.
3. () Reference dimensions only.

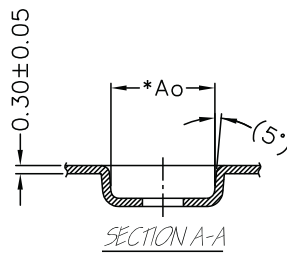

<i>Ao:</i>	3.80
<i>Bo:</i>	4.30
<i>Ko:</i>	1.20
<i>Pitch:</i>	8.00
<i>Width:</i>	12.00

Ordering Information

AEDR - 8600 - x0x

