

Adaptive front lighting connector board with VIPower board slot

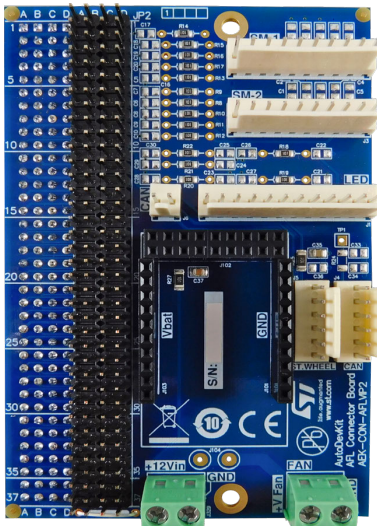

Features

- Designed to connect the following elements for a complete automatic front lighting (AFL) adjustment solution for a LED vehicle headlight:
 - An MCU board such as the AEK-MCU-C4MLIT1 with 4x37 connector
 - Two AEK-MOT-SM81M1 stepper motor boards
 - An AEK-LED-21DISM1 LED driver control board with two L99LD21 LED drivers and providing four independent channels
 - An EV-VNx actuator board such as the EV-VN7050AS to switch a headlight colling fan on and off
- Connected boards are controlled via three separate SPIs
- Input voltage from 8 V_{DC} to 15 V_{DC}
- Board size: 65 x 100 mm. Maximum component height: 27 mm
- Cables included for two stepper motor boards and one LED driver board
- WEEE and RoHS compliant
- All ST components are qualified Automotive grade
- Part of the AutoDevKit initiative



Description

The **AEK-CON-AFLVIP2** connector board is designed to connect a car headlight solution demo featuring automatic adjustment of the low beam direction based on road geometry and tilt angles affected by weight distributions inside the car.

The board can connect an MCU discovery board, such as the **AEK-MCU-C4MLIT1** (with 4x37 connector), with two **AEK-MOT-SM81M1** stepper motor boards governing low beam direction (left-right and up-down), and a **AEK-LED-21DISM1** LED driver board capable of supplying the different LED lights included in a modern front headlight assembly. It can also connect a high-side switch board from the EV-VNx range (e.g., EV-VN7050AS) to control a cooling fan for the LED headlight.

The **AEK-CON-AFLVIP2** board is part of the AutoDevKit initiative, which allows you to build and test various application prototypes from a set of available boards and generating the dedicated drivers and pin assignments using the **SPC5-Studio** integrated development environment.

| Product summary | |
|---|---|
| AutoDevKit connector board | AEK-CON-AFLVIP2 |
| MCU discovery board for SPC5 Chorus 4M automotive microcontroller with CAN transceivers | AEK-MCU-C4MLIT1 |
| AutoDevKit stepper motor driver board for automotive applications | AEK-MOT-SM81M1 |
| AutoDevKit digitally controlled LED driver board | AEK-LED-21DISM1 |
| Applications | Adaptive front lighting systems for vehicles Car chassis lighting Applications requiring up to 3 independent SPIs |

1 Overview

The **AEK-CON-AFLVIP2** connector board plugs onto the 4x37-pin MCU discovery board connector and the stepper motor and LED driver boards are connected by cable harnesses provided with the board. The EV-VN_x board can be plugged directly onto a dedicated slot on the same connector board.

Figure 1. AEK-CON-AFLVIP2 connector board block diagram

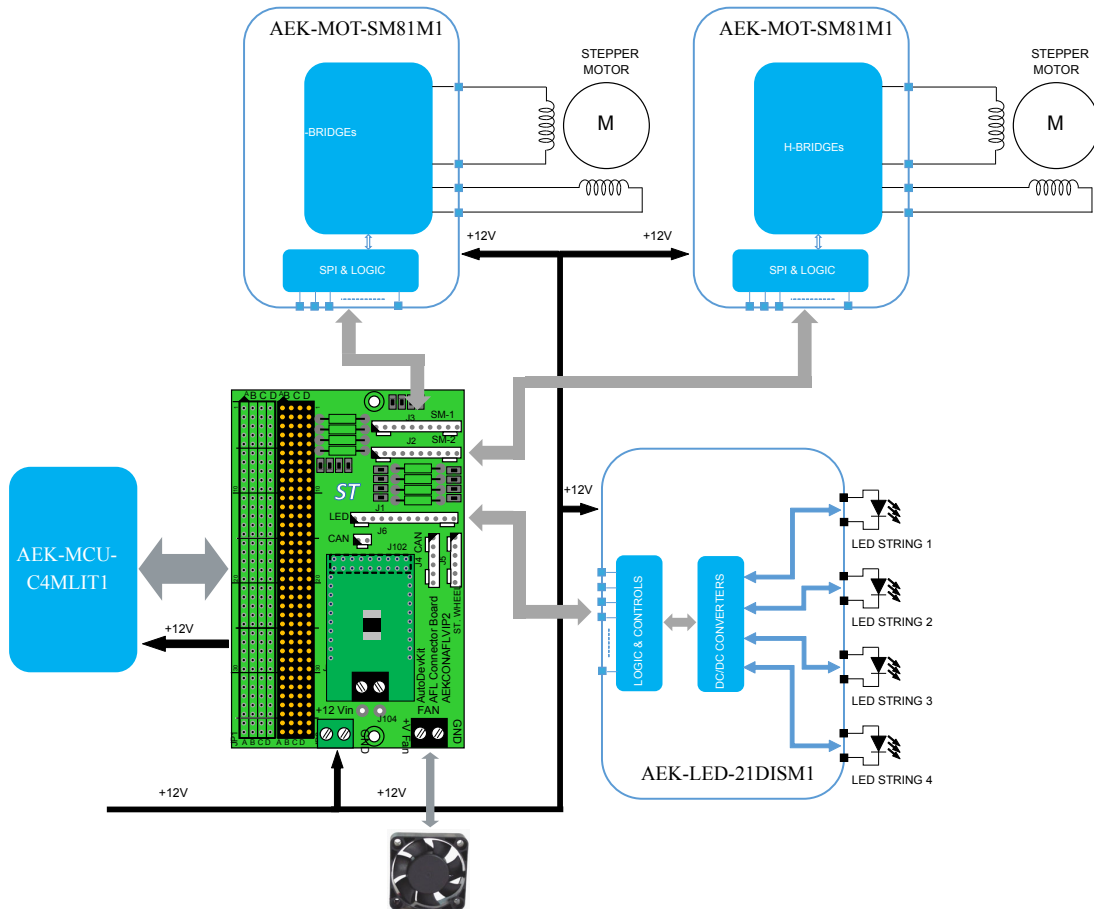

The board features three independent SPI buses to manage communication with the peripheral boards, while the EV-VN_x is directly controlled by a dc signal coming from an MCU GPIO pin. An additional 4x37 male connector is provided on the top layer of the connector board to allow for further expansions with additional functionality not included in the present solution demo.

Figure 2. AutoDevKit adaptive front lighting demonstration system

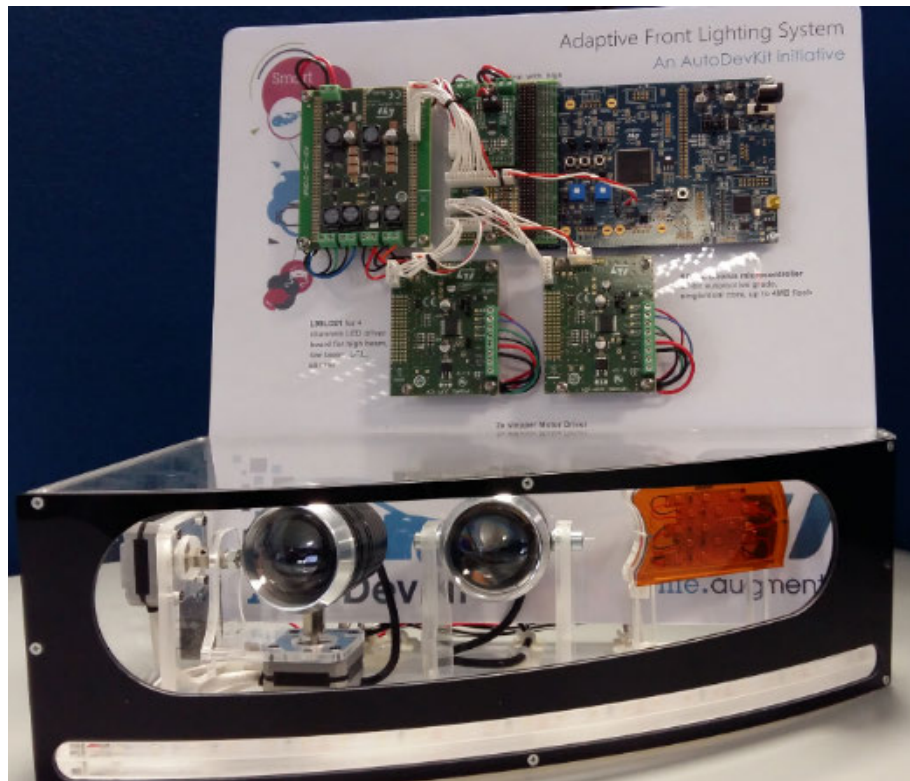

RELATED LINKS

[AutoDevKit: Adaptive Front Lighting demonstration kit video on YouTube](#)

2 Schematic diagrams

Figure 3. AEK-CON-AFLVIP2 schematic diagrams (1 of 2)

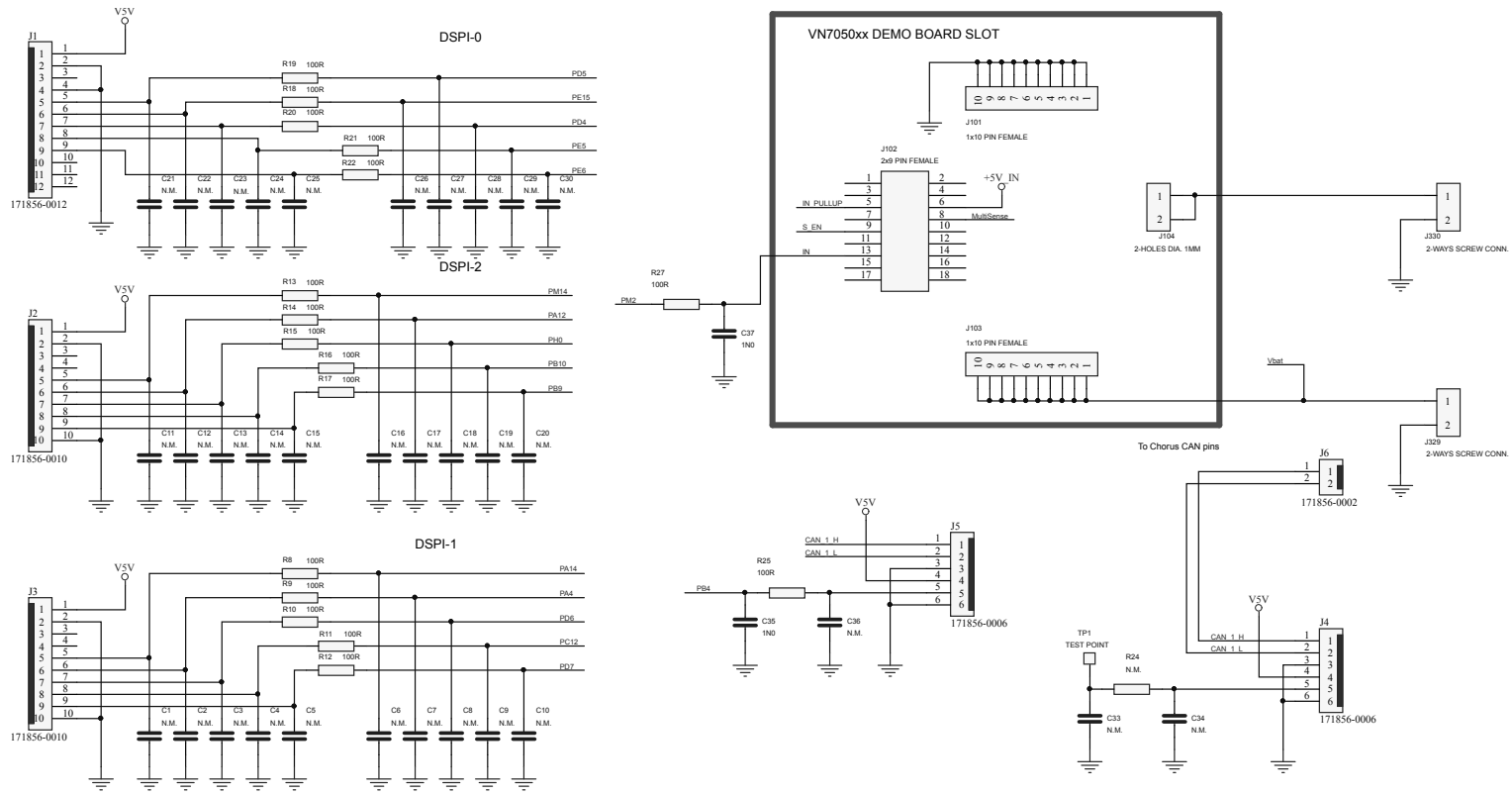
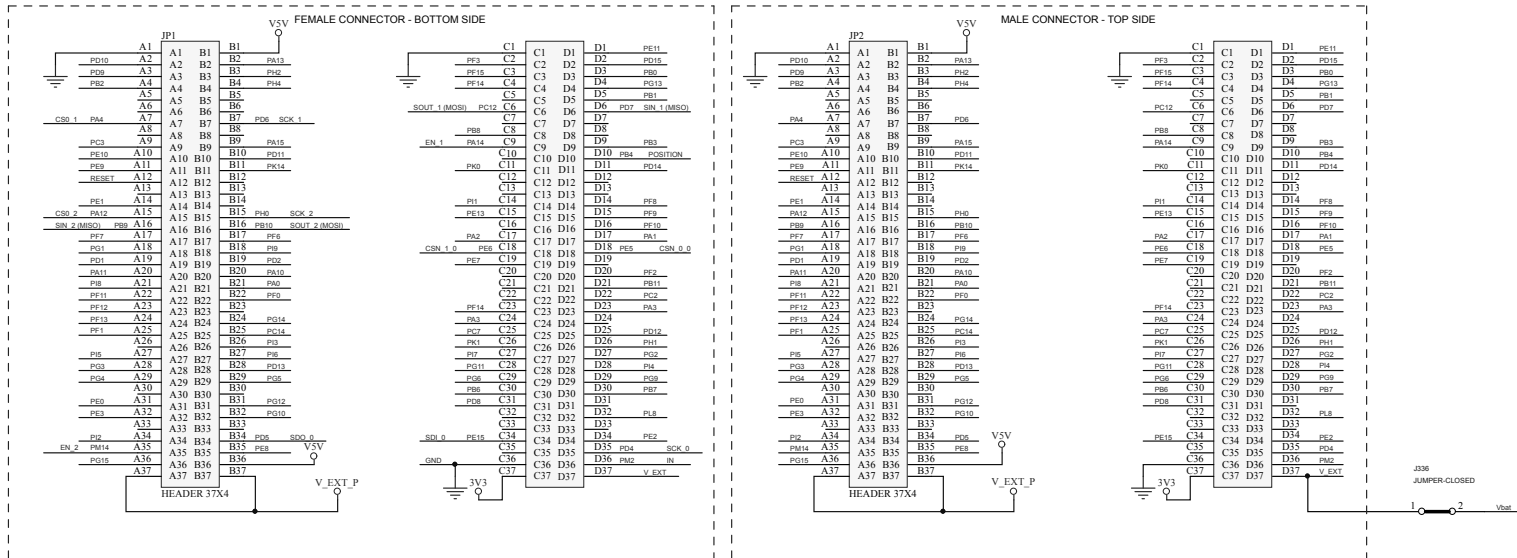

Figure 4. AEK-CON-AFLVIP2 schematic diagrams (2 of 2)



Revision history

Table 1. Document revision history

| Date | Version | Changes |
|-------------|---------|------------------|
| 23-Jul-2019 | 1 | Initial release. |