

## Up to 5 A digitally controlled DC-DC converter based on L5964 for automotive and transportation applications

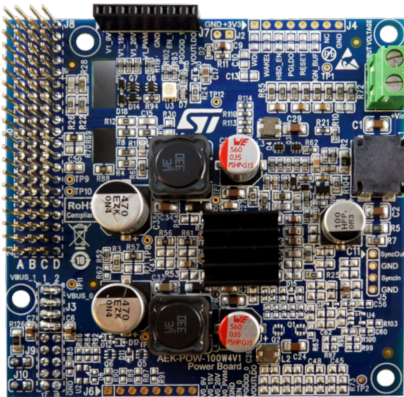

### Features

- Up to 100 W power on a single DC-DC channel
- Input voltage range: 6 V to 26 V
- MCU selectable fixed outputs: 3.3 V, 5 V, 9 V, 15 V, 20 V
- Programmable max. output current up to 5 A in steps of 50 mA
- Programmable output voltages: 20 mV steps from 3.3 to 11 V
- Short-circuit, overcurrent and thermal protections
- Size: 84.7 mm x 81.3 mm
- Included in the AutoDevKit initiative
- RoHS compliant

### Applications

- USB power delivery up to 100 W
- Baby milk bottle warmer
- Mini-fridge
- Laptop car charger
- In-car mini hair dryer
- In-vehicle power conversion

### Description

The **AEK-POW-100W4V1** is a very compact DC-DC converter for automotive and transportation applications which allows regulating the output voltage in the following modes: fixed outputs and Programmable Power Supply (PPS) in 20 mV steps.

The board allows setting the output current from a min. of 0.05 A to a max. of 5 A for the entire output voltage range in 50 mA steps.

It features several protection systems, such as short-circuit, overcurrent and thermal protection.

The AutoDevKit software library includes dedicated components able to configure and drive the board via ST microcontrollers.

Product summary	
Up to 5 A digitally controlled DC-DC converter based on L5964 for automotive and transportation applications	<a href="#">AEK-POW-100W4V1</a>
Monolithic dual 3.5 A step-down switching regulator with LDO	<a href="#">L5964</a>
Dual-port USB Type-C function board	<a href="#">AEK-USB-2TYPEC1</a>
MCU discovery board for SPC5 Chorus 4M automotive microcontroller with CAN transceivers	<a href="#">AEK-MCU-C4MLIT1</a>
Evaluation kit with dual-port USB Type-C function board and SPC58 Chorus discovery board	<a href="#">AEKD-USBTYPEC1</a>
Digitally controlled DC-DC converter with L5964 for automotive applications	<a href="#">AEK-POW-L5964V1</a>
AutoDevKit library plugin for SPC5-STUDIO	<a href="#">STSW-AUTODEVKIT</a>
Applications	<a href="#">Automotive USB Type-C Power Delivery</a>

# 1 Block diagram

Figure 1. AEK-POW-100W4V1 functional block diagram

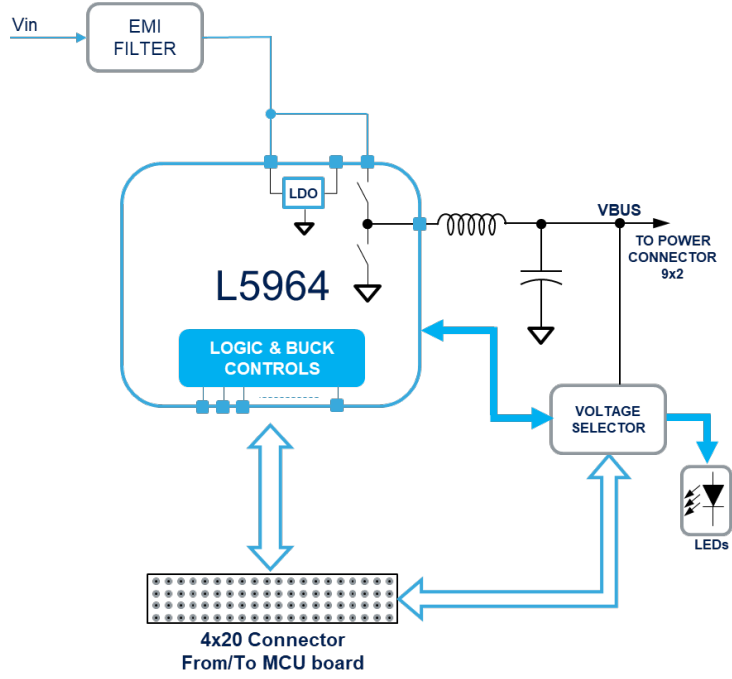

## 2 Hardware setup for USB-PD system level usage with AEKD-USBTYCEC1 kit

You can set the required voltage and current level for the available buck channel by using simple primitives in the microcontroller. Moreover, if the system is complemented with a current sense device, the software performs system control in closed loop (otherwise only open current loop control is possible).

The solution implementation is based on a microcontroller board plus a DC-DC power board, featuring Programmable Power Source (PPS) capabilities.

To build a complete USB-PD system, the following system components are required:

- an **AEK-MCU-C4MLIT1** microcontroller board
- an **AEK-USB-2TYCEC1** USB Type-C dual-port interface board
- USB power delivery protocol stack running on the microcontroller available in the [AutoDevKit](#)

### 2.1 Constant current mode

The **AEK-POW-100W4V1** embeds the circuitry to support constant current operation mode in both converters. In this operating mode, the converter stops maintaining constant output voltage like a voltage generator to start limiting the output current like a current source. This functionality is required to limit the output power in case of failures, as well as to charge the battery charging or connect a load behaving as a voltage source, as in the USB-PD 3.0 load direct charging operation.

The circuit is based on an additional error amplifier in which the output pin is OR-ed with the voltage loop error amplifier output pin (COMP). Voltage and current loops regulate the output voltage or current according to the load resistance value.

The error amplifier inverting input is connected to the current sensing circuit. The current sensing circuitry is not present on the **AEK-POW-100W4V1** power board as it is implemented on the **AEK-USB-2TYCEC1** dual-port USB Type-C expansion board: signals can be routed to the power board via the 4x20 pin connector J8 (I\_SENSE\_x).

**Figure 2. Signal routing diagram**

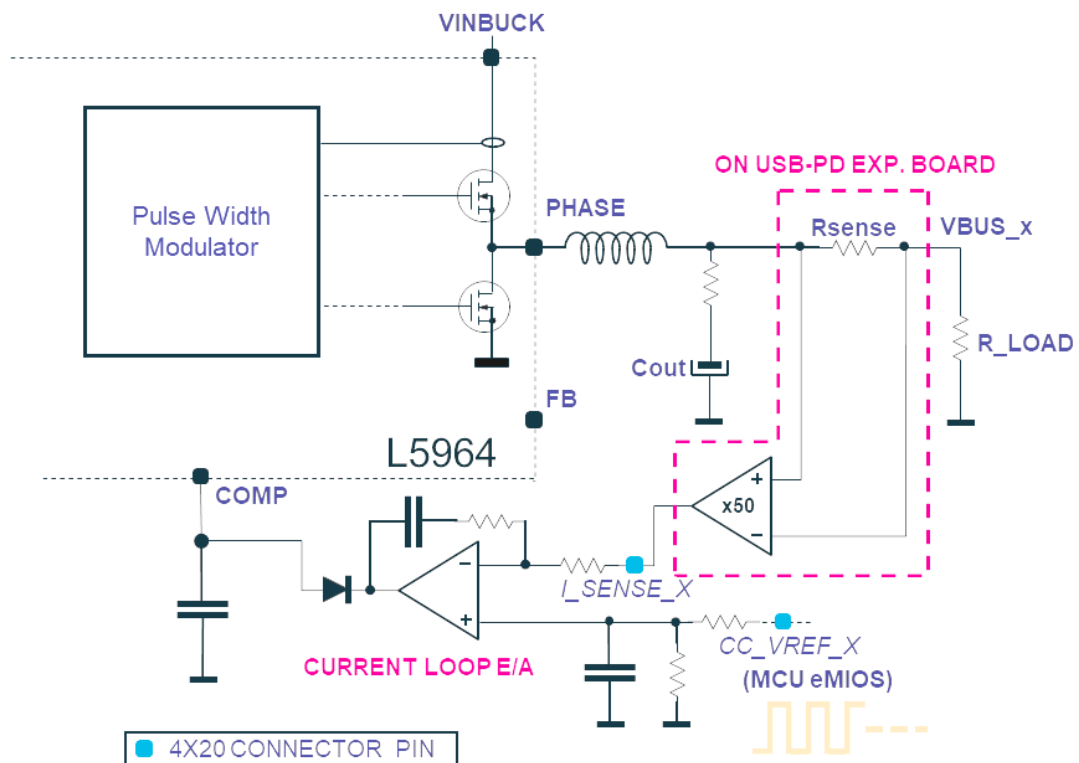

## 2.2 USB Type-C™ and current sensing

The AEK-USB-2TYPEC1 features USB type-C state machine for attachment/detachment and cable orientation detection, high voltage protections on  $V_{BUS}$  and CC lines,  $V_{BUS}$  switch gate drivers,  $V_{BUS}$  monitoring and discharging path and a current sensing circuit for each  $V_{BUS}$  line port.

To use the AEK-USB-2TYPEC1 for current sensing on the AEK-POW-100W4V1 board, decrease the gain of the current sensing signal amplifier (U801) from 100 to 50 by unsoldering the resistor from position R803 to solder it in position R804.

The AEK-USB-2TYPEC1 hosts two USB Type-C port interfaces, but only one (CN701) can be used with the AEK-POW-100W4V1 power board, thus the second one (CN401) has to be disabled by removing R304 resistor.

**Figure 3. AEK-USB-2TYPEC1 configuration for current sensing**

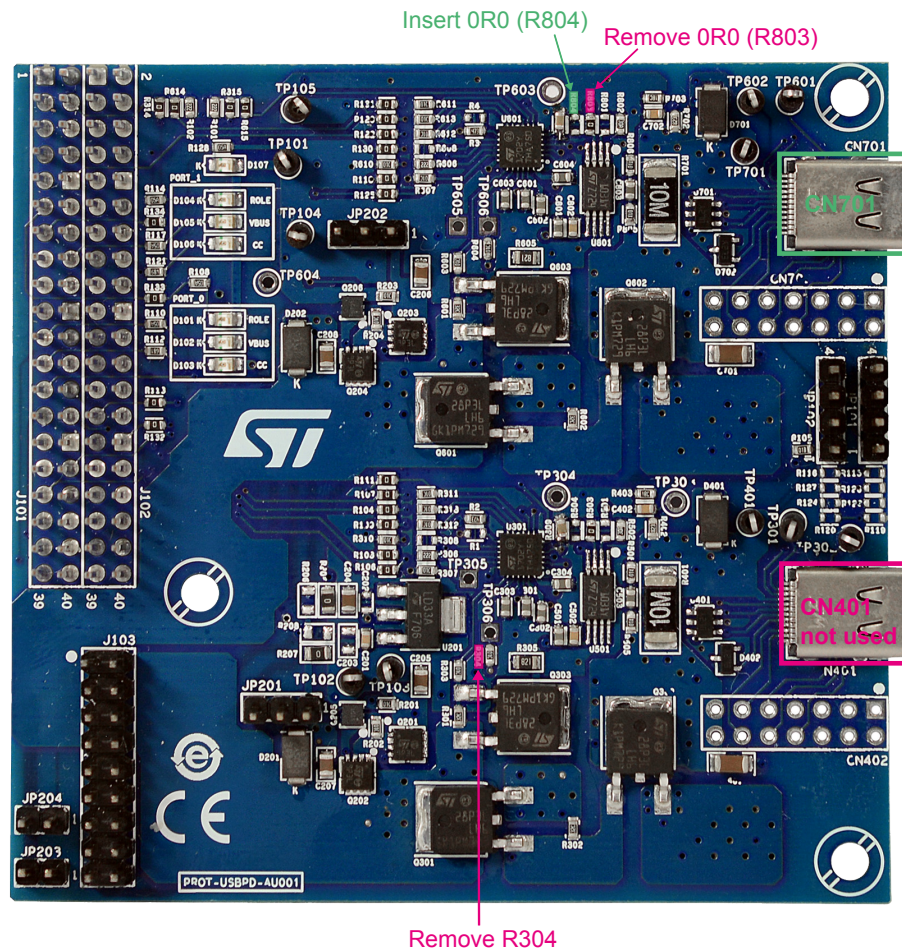

# 3 Schematic diagrams

Figure 4. AEK-POW-100W4V1 circuit schematic

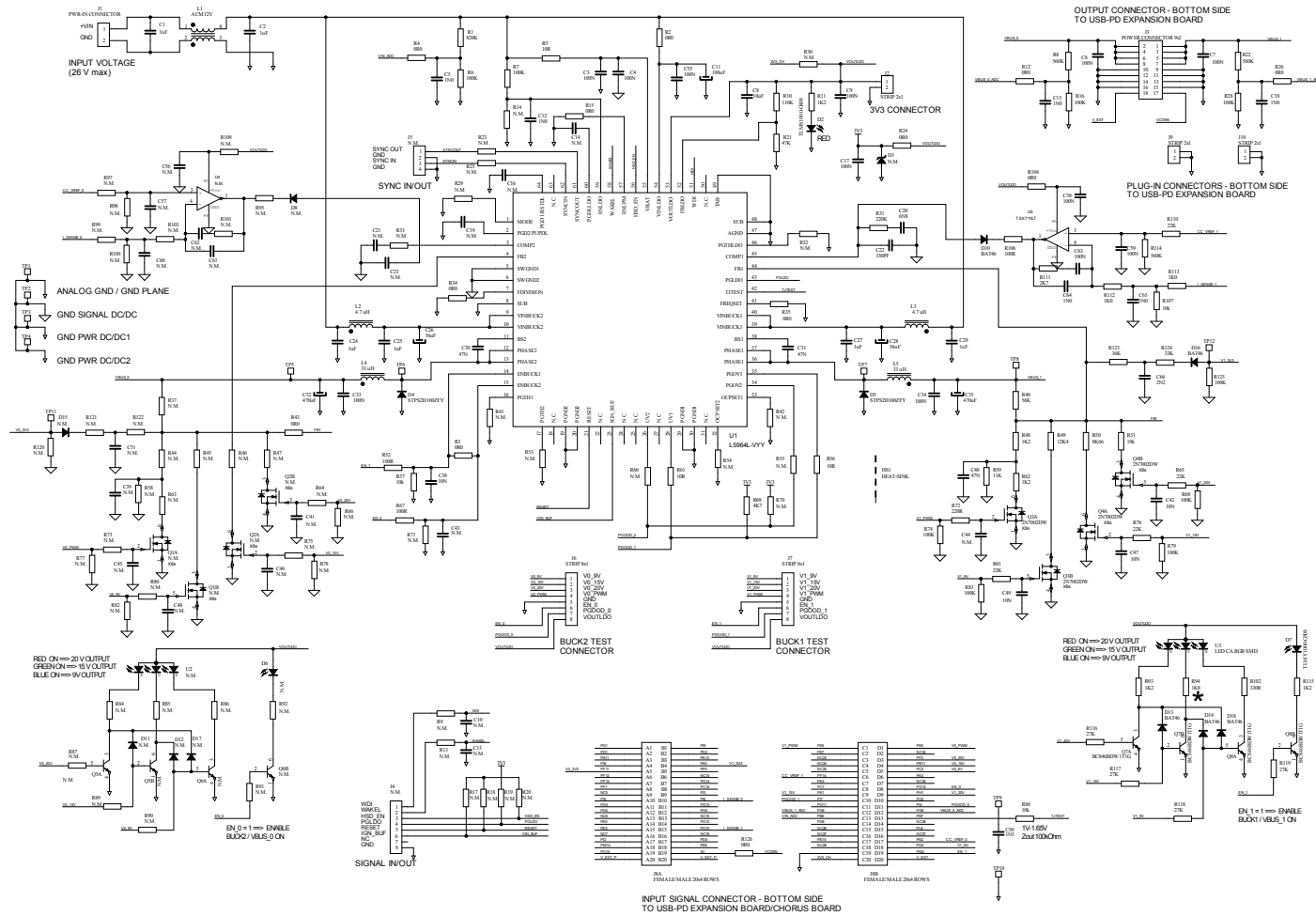

## Revision history

**Table 1. Document revision history**

Date	Version	Changes
04-Nov-2020	1	Initial release.
20-Jan-2021	2	Minor text changes throughout the document. Added Section 2 Hardware setup for USB-PD system level usage with AEKD-USBTPEC1 kit, Section 2.1 Constant current mode and Section 2.2 USB Type-CTM and current sensing.