

## Adaptive Front Light testing and prototyping kit arranged on plexiglass panel

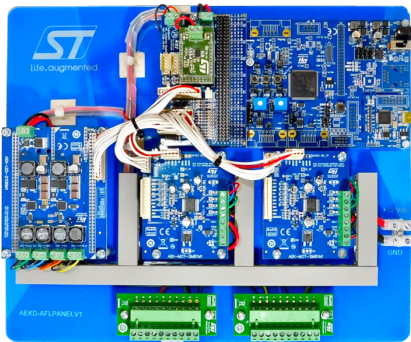

### Features

- Panel arrangement of boards forming an adaptive front light (AFL) system.
- Panel size: 330 x 270 x 40 mm (approx.).
- Designed for application development and testing, allowing rapid interchanging of function and control boards.
- Several evaluation boards mounted on panel provide independent control of:
  - two stepper motors for light projection angle adjustment (X and Y directions)
  - LED string currents for high beam, low beam, daytime running lights (DRL) and direction lights
  - a cooling fan
- All the above loads are included in the (AEKD-AFLLIGHT1) headlight assembly, available separately.
- Kit supplied complete with cables and connectors.
- Includes control board with SPC5 Chorus MCU to monitor entire system.
- Dedicated STSW-AFL001 firmware running on MCU includes sample code modules covering typical AFL functionality.
- Special connector board to easily link demo boards with MCU board.
- WEEE and RoHS compliant.
- All ST components are qualified Automotive grade.
- Part of the AutoDevKit initiative.



Product summary	
Plexiglass panel with AutoDevKit boards for vehicle adaptive front light systems	<a href="#">AEKD-AFLPANEL1</a>
Adaptive front lighting motor, light and fan loads for AutoDevKit	<a href="#">AEKD-AFLLIGHT1</a>
AutoDevKit adaptive front lighting kit firmware	<a href="#">STSW-AFL001</a>
Applications	Adaptive front lighting systems for vehicles Car chassis lighting

### Description

The [AEKD-AFLPANEL1](#) is a panel assembly of the driving hardware for an adaptive front light testing system featuring ST AutoDevKit boards on a specially designed perspex board that facilitates development and prototyping activities.

The panel provides a tidy arrangement of two stepper motor control boards, a four-channel LED driver board, a control board with SPC5 Chorus microcontroller for automotive applications, a connector board with a FAN switch board and further connector board for wiring configuration.

Used in conjunction with the [AEKD-AFLLIGHT1](#) demo automotive headlight assembly with LED lights, stepper motors and fan, these two kits provide a complete adaptive front lighting tool for application and solution development purposes.

## 1 Adaptive front lighting simulation tool overview

The set of AutoDevKit boards in this kit, together with the relevant firmware and sample application code in the [STSW-AFL001](#) software package, form a system that is able to control and drive an automotive adaptive front loading system for development purposes.

To build a complete physical simulation tool, the system must be complemented with appropriate loads, feedback sensors and communication ports.

**Figure 1. AutoDevKit adaptive front lighting system block diagram**

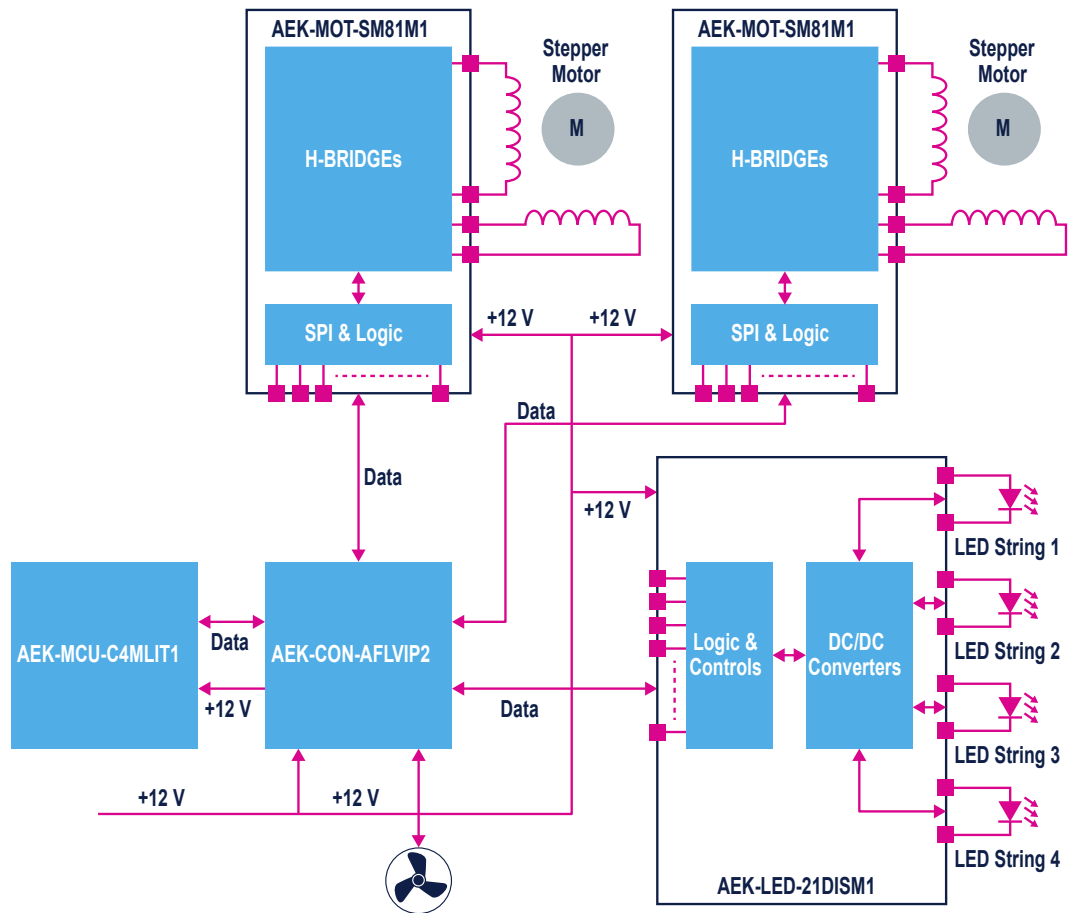

In the block diagram above, the loads are clearly indicated by the following elements:

- two stepper motors: one for up-down and one for lateral angular displacement of a light
- four LED lighting strings: high beam, low beam, DRL, direction light
- a cooling fan

ST conveniently supplies all of the above items in a single [AEKD-AFLLIGHT1](#) assembly inside a specially designed acrylic shroud with appropriate cabling and connectors.

**Figure 2. Adaptive front lighting headlight assembly**

1. Perspex headlight housing
2. turn indicator LED string
3. high beam LED light
4. low beam LED light
5. daytime running light LED string
6. adaptive X-axis position stepper motor
7. adaptive Y-axis position stepper motor
8. cooling fan
9. JPX2 connector
10. JPX3 connector

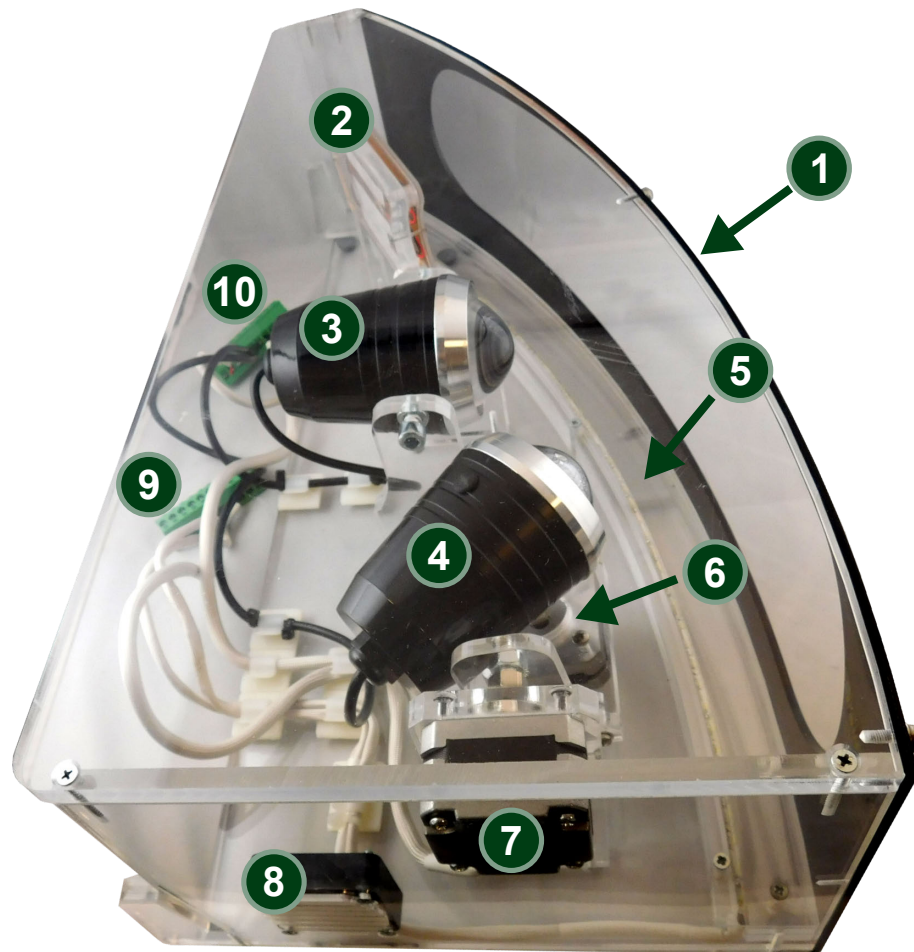

A real adaptive front lighting system would receive feedback data from sensors indicating the position or orientation of the motor vehicle steering wheel. This feedback information can be emulated with a potentiometer signal plugged to connector J5 (labeled ST.WHEEL) on the [AEK-CON-AFLVIP2](#) connector board, where different voltages will represent different steering wheel positions.

**Important:**

In order to enable manual steering wheel control, you must open the AutoDevKit library AFL demo project in [SPC5-STUDIO](#) and change the `#DEFINE AFLDemo_ManualMode` to `true` in the `AFL.h` file.

To ensure that manual operation does not remain the default mode when the system starts, short pins 5 and 6 of the J5 connector.

**Figure 3. AEK-CON-AFLVIP2 J4 (ST.WHEEL) and J5 (CAN) connectors**

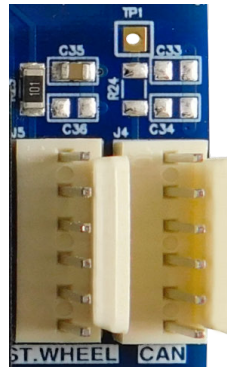

To connect the electronic control unit (ECU) with other ECUs such as the body control module (BCM) and/or cluster (to signal the actuation being performed on the dashboard), you can connect a CAN bus analyzer to connector J4 (labeled CAN) on the [AEK-CON-AFLVIP2](#) connector board. The analyzer shows the basic CAN messages that are transmitted when a single actuation in the headlight is performed. The CAN messages and periodicity can be customized using [SPC5-STUDIO](#) to edit the AFL demo available in the AutoDevKit library.

---

**RELATED LINKS**

[AutoDevKit: Adaptive Front Lighting demonstration kit video on YouTube](#)

---

## 2 Schematic diagrams

Figure 4. AEKD-AFLPANEL1 schematic diagram

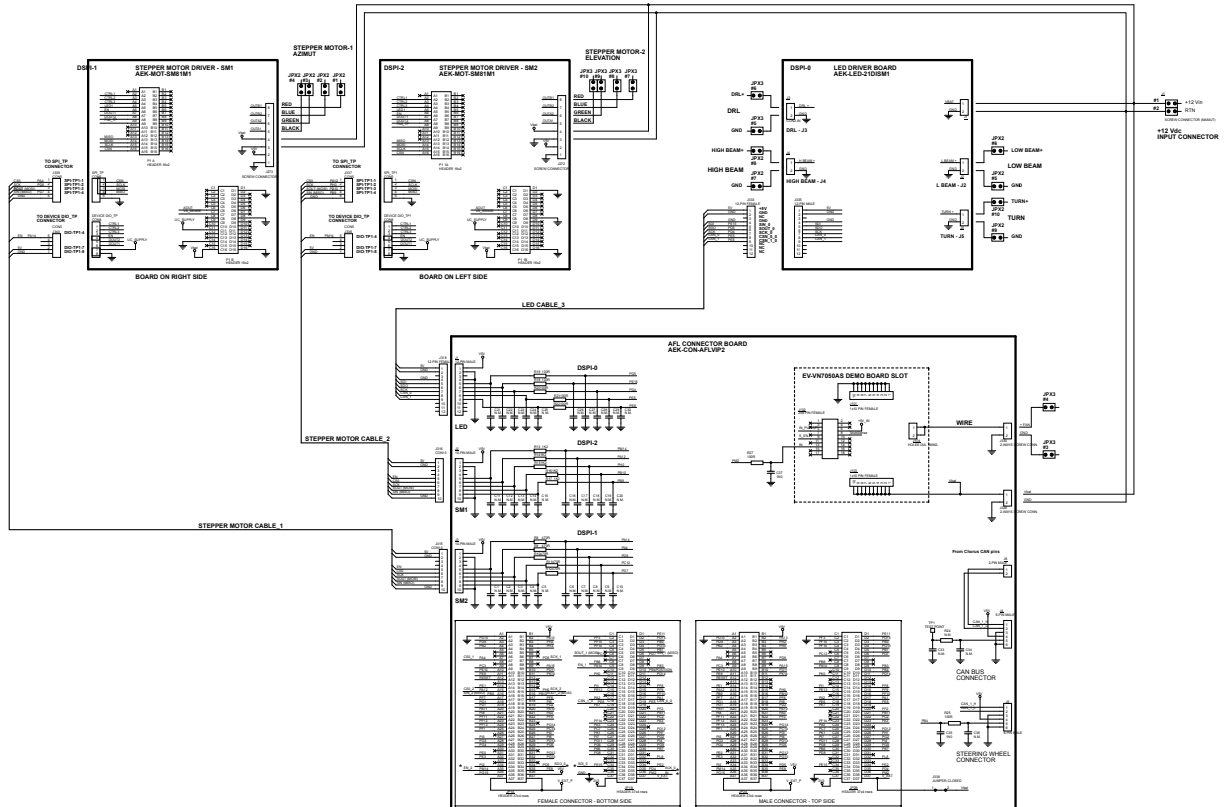

## Revision history

**Table 1. Document revision history**

Date	Version	Changes
26-Sep-2019	1	Initial release.