

## Set of assembled boards for blind-spot detection simulation



### Features

- Full set of evaluation boards to drive vehicle blind-spot application development:
  - **AEK-MCU-C4MLIT1**: main control board with **SPC58EC80E5** automotive microcontroller running firmware to interpret detected magnetic field variations
  - **AEK-LED-21DISM1**: advanced automotive-grade LED driver board used to activate the vehicle in blind-spot warning LED
  - **EV-VN7050AS**: high-side driver used to drive the DC gearbox motor of the conveyor belt
- Unique power supply path for all boards and the hardware assembly
- 5 V, 2 A AC-DC included
- Part of the **AutoDevKit™** initiative
- RoHS and WEEE compliant

### Description

The **AEKD-BLINDSPOTB1** set of assembled evaluation boards is used with the **AEKD-BLINDSPOTA1** car model demonstration assembly to simulate vehicle detection in automotive blind-spot regions. It achieves this by interpreting magnetic field variations detected by a Hall sensor mounted near a stationary model car, caused by magnets mounted on another model car approaching on a conveyor belt driven by a 12 V<sub>DC</sub> gearbox motor with 40 RPM and high torque.

The goal of the training kit is to support firmware development of blind-spot applications using the **SPC5-Studio** integrated development environment with **AutoDevKit** plugin extension, which includes the source code.

The system can be tested using the **STSW-BLINDSPOT** firmware downloadable from [www.st.com](http://www.st.com).

Product summary	
Blind-spot board panel	<b>AEKD-BLINDSPOTB1</b>
Firmware for AEKD-BLINDSPOTB1	<b>STSW-BLINDSPOT</b>
Development environment	<b>SPC5-Studio</b>
<a href="http://community.st.com/autodevkit">community.st.com/autodevkit</a>	<b>AutoDevKit</b>
AutoDevKit library plugin for SPC5-STUDIO	<b>STSW-AUTODEVKIT</b>
SPC5-UDESTK Debugging Software for Windows	<b>SPC5-UDESTK-SW</b>
MCU discovery board for SPC5 Chorus 4M automotive microcontroller with CAN transceivers	<b>AEK-MCU-C4MLIT1</b>
Digitally controlled LED driver board for automotive lighting applications	<b>AEK-LED-21DISM1</b>
VN7050AS evaluation board based on VIPower M0-7 technology	<b>EV-VN7050AS</b>
Applications	<b>Chassis and Safety</b>

# 1 Overview

Blind-spot detection is implemented in modern transportation vehicles to prevent accidents in common overtaking scenarios and other dangerous circumstances involving vehicles occupying areas that cannot be seen directly by the drivers of other vehicles. These warning systems detect the presence of vehicles in blind-spot zones and alert the driver.

In this simulation kit, the system consists of a plexiglass structure to simulate the loads and a set of boards to drive the application (AEKD-BLINDSPOTB1). Two cars are placed on the demo: one is stationary, while another car with embedded magnets moves on the conveyor belt driven by a gear-DC motor. A Hall sensor under the belt measures the magnetic field around it and a LED near the stationary car indicates when the blind-spot warning signal is triggered.

The application is controlled by:

- a 32-bit automotive microcontroller (SPC58EC80E5)
- a VIPower actuator board (EV-VN7050AS) with a high side driver used to drive the conveyor belt geared DC motor
- a LED driver board (AEK-LED-21DISM1) drives the warning LED

**Figure 1. AEKD-BLINDSPOTA1 hardware assembly**

1. Side for board connection
2. LED
3. DC motor
4. Hall sensor
5. Car with magnets

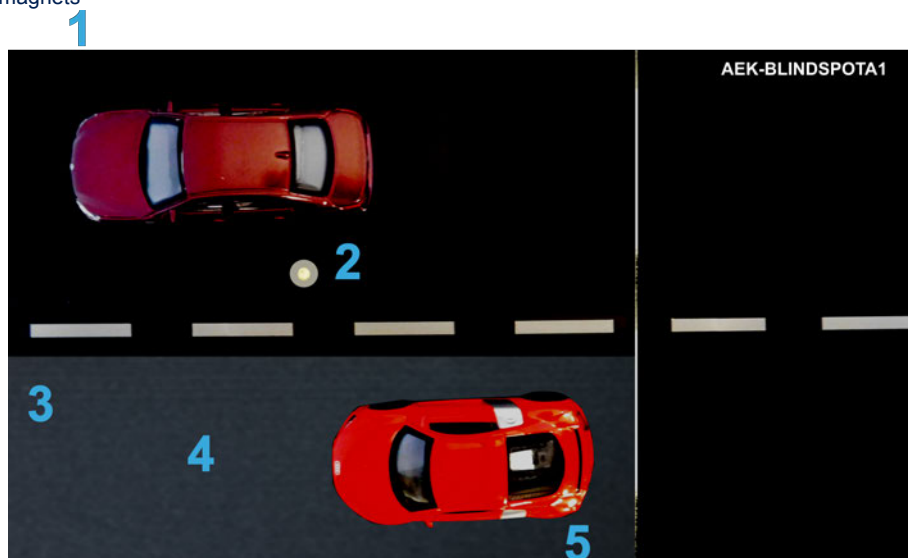

## 1.1 Block diagram

Figure 2. AEKD-BLINDSPOTA1 plus AEKD-BLINDSPOTB1 blind-spot detection kit component block diagram

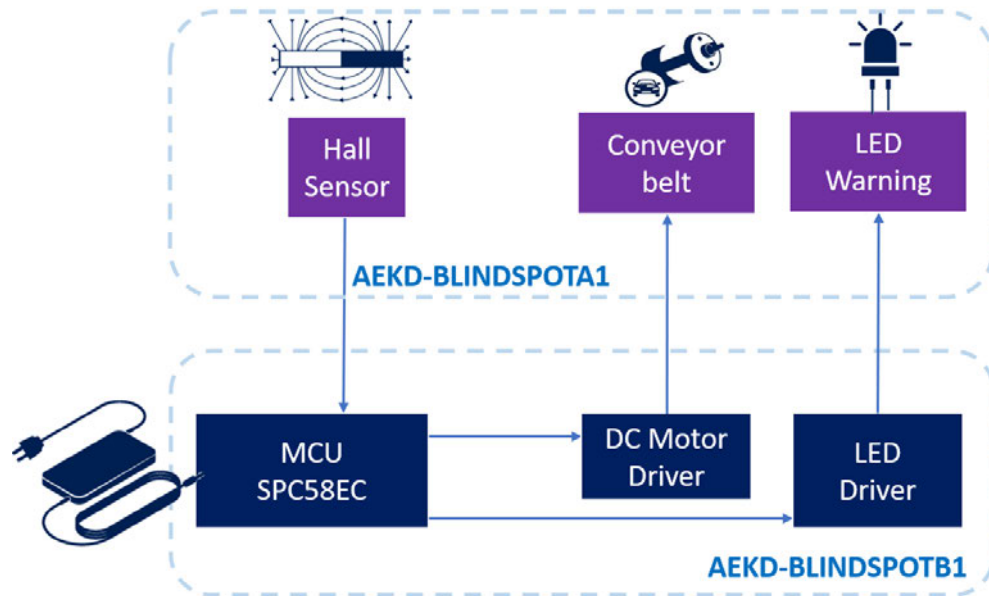

## 1.2 How to create a blind-spot detection application using AutoDevKit

- Step 1.** Create a new project and select the MCU platform to use, i.e. SPC58 Chorus 4 Mb
- Step 2.** Add SPC5 Init Component for clock configurator, interrupt management and an operating system abstraction layer together with bootstrap files
- Step 3.** Add AutoDevKit Init Component for Board View Editor
- Step 4.** Add low-level drivers for MCU peripherals management
- Step 5.** Pick AutoDevKit components according to the blind-spot warning system to build: LED driver, DC motor driver for the conveyor belt and the Hall sensor capture component
- Step 6.** Configure the added AutoDevKit components
- Step 7.** Run automatic pin allocation
- Step 8.** Verify the assigned pins in the PinMap Editor
- Step 9.** Connect your boards using the Board View
- Step 10.** Write the `main()` function using AutoDevKit with high-level APIs

**Figure 3.** `main()` function operation block diagram

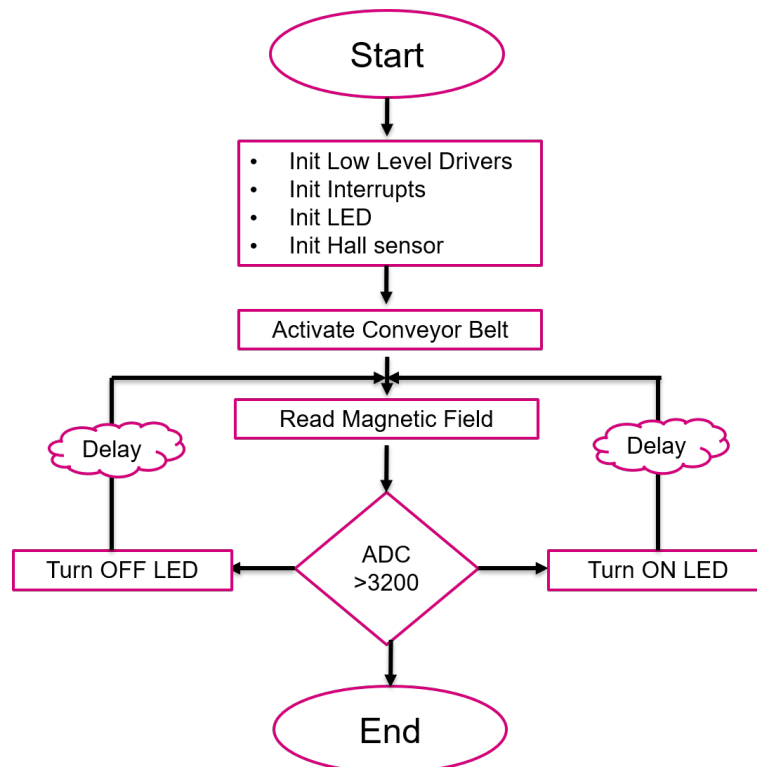

- Step 11.** Compile the code
- Step 12.** Download the code using PLS UDE
- Step 13.** Debug your application

## Revision history

**Table 1. Document revision history**

Date	Version	Changes
13-Feb-2020	1	Initial release.
04-Mar-2020	2	Minor text changes.