

# AFBR-S4E001

## Evaluation Kit for the AFBR-S4NxxC01y SiPM Family

### Overview

This application note introduces the evaluation kit AFBR-S4E001, which has been designed to be used as an evaluation platform for the AFBR-S4NxxC01y SiPM family.

The document describes in detail the board included in the evaluation kit and the test setup used for the evaluation of the optical and electrical characteristics of the mentioned SiPM family.

Figure 1 shows the front and back sides of the evaluation board for the AFBR-S4E001.

### Features

- Two 50Ω outputs
- Designed for applications involving many photons, typically produced by a scintillator
- Operating Temperature range from -20°C to +50°C
- RoHS and REACH compliant

Figure 1: Evaluation Board from Front (Left) and Back (Right)

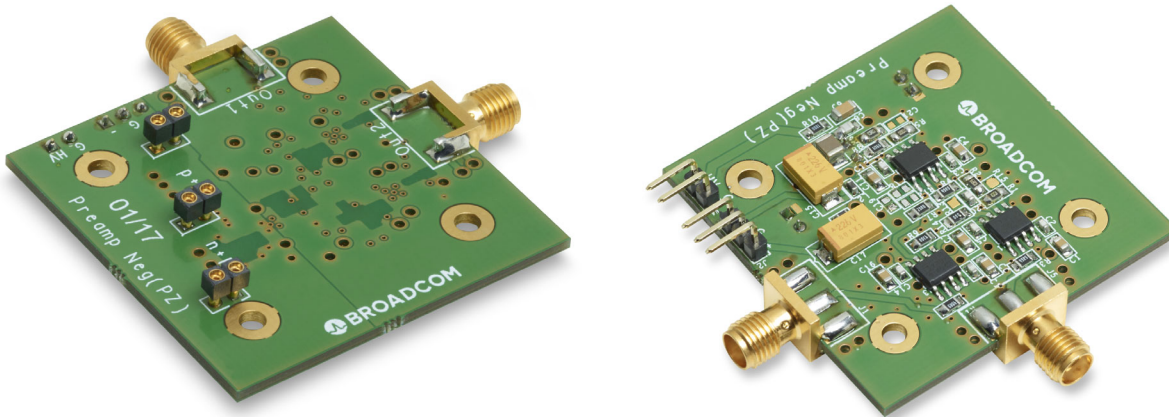

### Evaluation Kit

The evaluation kit includes:

- 1x Evaluation board
- 1x AFBR-S4N44C013 SiPM (mounted on a test PCB)

The evaluation kit does not include:

- SiPM High Voltage source (up to ~40V)
- Dual power supply ( $\pm 2.5V$  to  $\pm 8.5V$ )
- SMA cables for readout

### Applications

- Prototyping
- Device characterization
- X and  $\gamma$  ray spectroscopy
- PET

# Description

The block diagram is displayed in [Figure 2](#):

**Figure 2: Block Diagram**

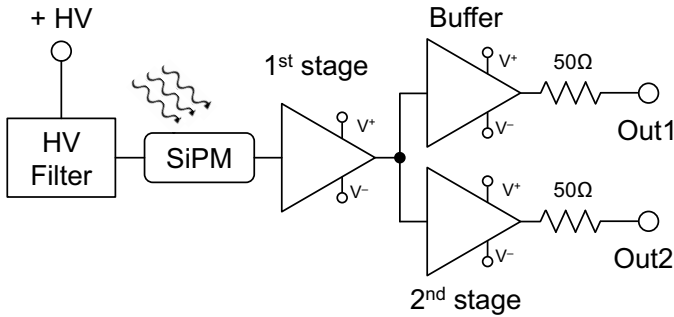

The high voltage is filtered before being applied to the SiPM to minimize the fluctuations in the voltage source. The SiPM output signal goes into a first stage of amplification based on an operational amplifier in trans-impedance configuration. Its output is then split into two lines: the first goes through a buffer with unity gain and is connected to Out1; the second passes through a second stage of amplification including a Pole-Zero (PZ) filtering network and is connected to Out2. Given a flash of light, Out1 is used to estimate the number of detected photons while Out2 gives a precise determination of the timing. Both outputs should be read through a 50Ω termination resistor.

## Inputs and Outputs

The board has three inputs (SiPM signal, SiPM high voltage, and power supply) and two outputs (Out1 and Out2). Two additional receptacles are included for mechanical stability only. [Figure 3](#) and [Figure 4](#) show a sketch of the board front and back view, respectively.

**Figure 3: Evaluation Board Frontside**

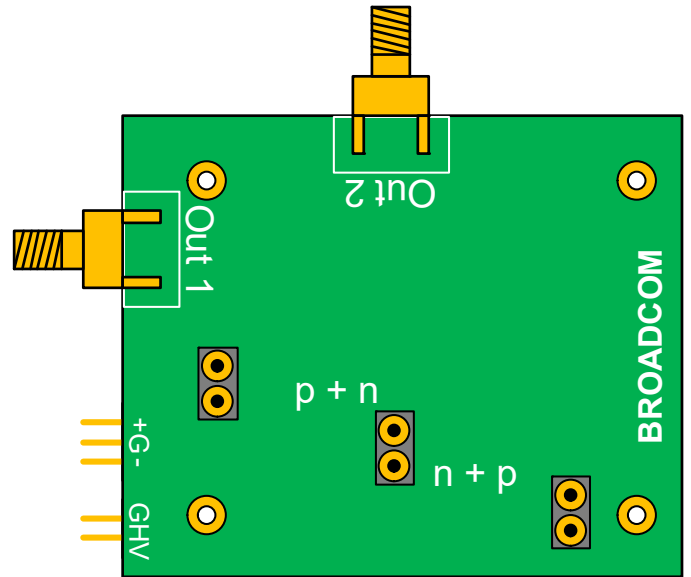

**Figure 4: Evaluation Board Backside**

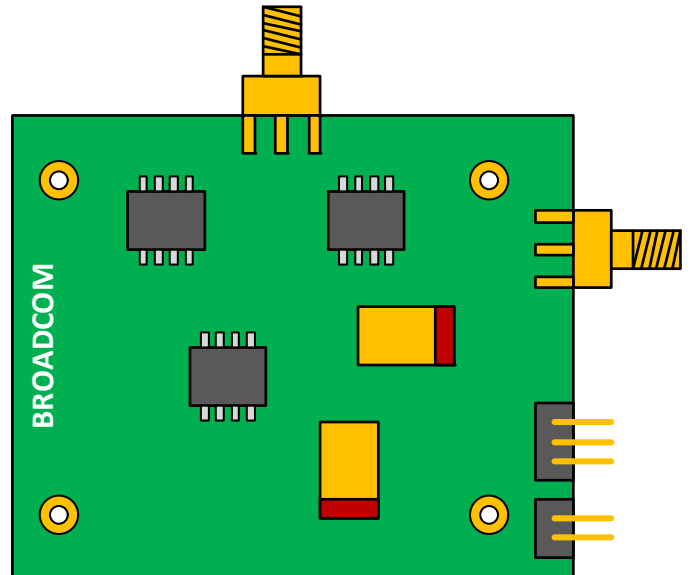

## Detailed Pin Descriptions

### SiPM Input

The detector must be connected as shown in [Figure 5](#).

Figure 5: Connection with SiPM PCB

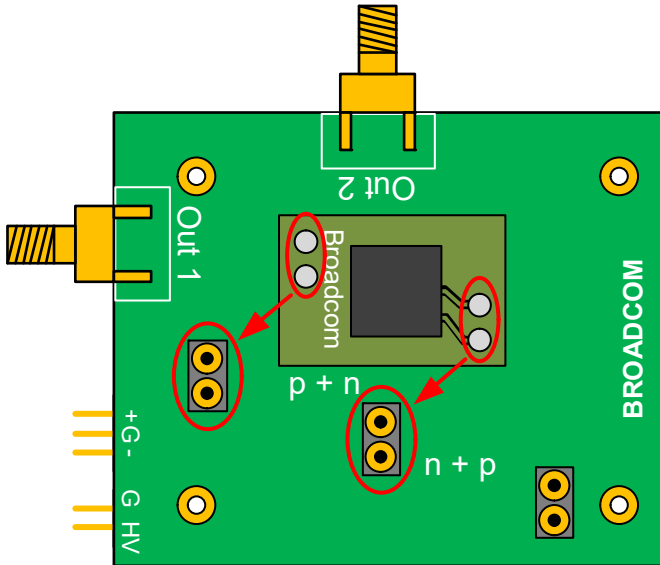

The anode and cathode of the detector are connected to the amplifier's input while the other receptacle has no electrical connection and is only used for mechanical stability.

### SiPM High Voltage

SiPM high voltage is provided with the 2-pole connector displayed in [Figure 6](#). The supply voltage must be positive.

Figure 6: SiPM High Voltage Connector Detail



### Board Power Supply

Power for the board is provided by the 3-pole connector displayed in [Figure 7](#).

Figure 7: Board Power Supply Connector Detail

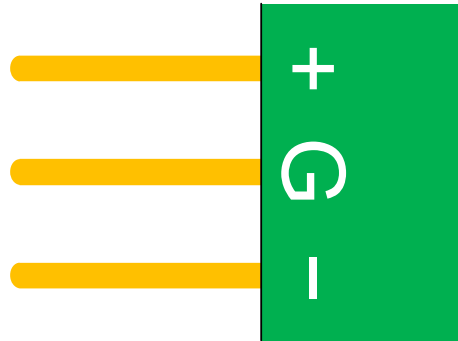

Suggested starting values:

- $V^+$ : +5V
- $V^-$ : -5V

With the suggested values, the absorbed current in each line is approximately 40 mA. The output signals can range from -3.8V to + 3.8V ( $\pm 1.2V$  is used by the op-amp and is unavailable). Since Out1 is negative and Out2 is positive, the user might want to shift the output dynamic to avoid saturation in one of the outputs. Typically, it is crucial to avoid saturation on the Energy channel rather than the Timing channel. The reason for this is that the Timing signal carries the most useful information in the very beginning of its rising edge, where saturation is not an issue.

To shift the output range, adjust the bias voltages and keep the overall difference within 11V max. (10V suggested, for safety). Additionally, each voltage cannot be lower than  $\pm 2.5V$  or higher than  $\pm 8.5V$ .

In summary:

- $+ 2.5V \leq V^+ \leq +8.5V$ ;
- $-2.5V \geq V^- \geq -8.5V$ ;
- $V^+ - V^- \leq 11V$ ;

## Out1: Energy

Out1 is the output of the first stage of amplification.

The polarity is negative. The gain of the amplification stage (also accounting for termination) is  $G = 83 \text{ V/A}$ . An offset of a few tens of millivolts with respect to ground is common and is due to the operational amplifier chip. The exact value changes from sample to sample and can be positive or negative.

Out1 preserves the signal shape and thus can be integrated to obtain the delivered charge, a quantity that is proportional to the number of detected photons. In a typical application with a scintillator, this quantity is also proportional to the energy of the detected X or  $\gamma$  ray. Hence, Out1 is referred to as the Energy signal.

## Out2: Timing

Out2 is the output of the second stage of amplification. The polarity is positive. The gain of the amplification stage is not defined because of the presence of the PZ network.

The PZ filter is designed to change the signal shape. Specifically, it suppresses the recovery tail of the SiPM signal thus reducing the baseline fluctuations due to dark counts. As a consequence, the extraction of the timing information (when using a simple leading edge discriminator [LED], as an example) is more accurate and allows for improved timing resolution performance. Hence, Out2 is referred to as the Timing signal.

## Example of Operation and Sample Signals

The typical test setup is pictured in [Figure 8](#).

Figure 8: Typical Test Setup Scheme

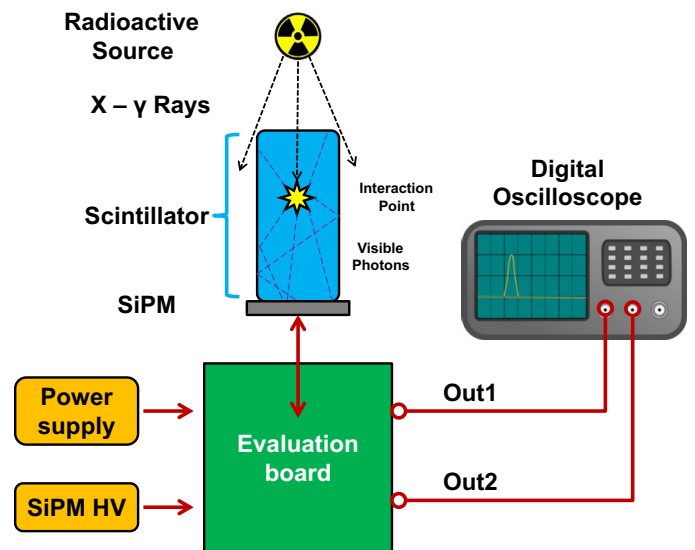

The scintillator converts the energy from the X -  $\gamma$  ray into many visible photons which are then detected by the SiPM. The interaction between the radiation and the scintillator can be of two types: photoelectric effect or Compton scattering. In the first case, the X -  $\gamma$  ray is absorbed and all the energy is deposited. With the Compton scattering, however, the X -  $\gamma$  ray is not absorbed and only a fraction of its energy is released into the scintillator.

Each detection event is randomly a Compton scattering or a photoelectric effect, according to a distribution that strongly depends on the atomic number of the scintillator and the radiation energy. Different materials have different characteristics in terms of density, number and wavelength of produced photons, and emission time. The choice of the material strongly depends on the energy of the radiation that has to be detected.

The following example signals can be obtained with a typical test setup. The scintillator is a commercially available LSO crystal with dimensions of 4 mm x 4 mm x 20 mm. The employed radioactive source is  $^{22}\text{Na}$  and emits two primary gamma lines at energies of 511 keV and 1274 keV. The setup is completed by the digital oscilloscope from LeCroy (model WavePro 760Zi-A with 6 GHz of bandwidth and a 40 GS/s sampling rate).

A persistence of signals from Out1 is displayed on [Figure 9](#). The two most populated groups of events represent the 511 keV and 1274 keV energies. Events between the two families are referred to as Compton scattering interactions.

Figure 9: Example Output Signals from Out1

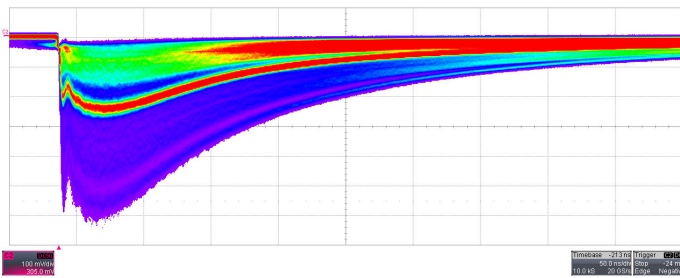

One example signal from Out2 is displayed in Figure 10. It can be seen that Pole-Zero filtering produces a much steeper signal optimized for the extraction of the timing information. The oscillations after the first peak are due to photons reaching the detector after the first bunch and oscillations of the op-amp. They do not deteriorate the performance because the best information about the time of arrival of the gamma ray is carried by the very first photons that contribute to the very first part of the first rising edge. For optimal operation, it is thus suggested to set a low threshold (as close as possible to the baseline fluctuation level), and consider only the first threshold crossing.

Figure 10: Example Output Signal from Out2

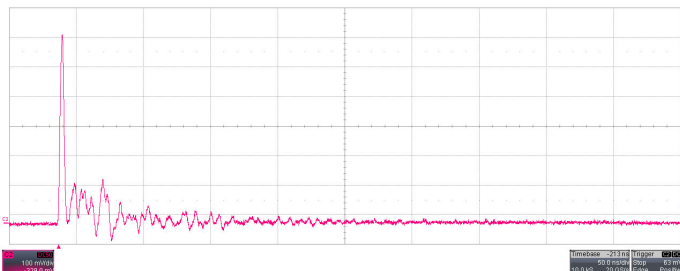

## Absolute Maximum Ratings

Stresses in excess of the absolute maximum ratings can cause damage to the circuit. Limits apply to each parameter in isolation. Absolute maximum ratings are those values beyond which damage to the board may occur if these limits are exceeded for more than a short period of time.

Table 1: Absolute Maximum Ratings

Parameter	Symbol	Min.	Max.	Unit
Storage Temperature	TSTG	-20	+60	°C
Operating Temperature	TA	-20	+50	°C
Op-amp Dual Voltage	V±	±2.5	±8.5	V
Op-amp Total Voltage Difference	V <sup>+</sup> - V <sup>-</sup>		11	V
Supply Current	I±		100	mA