

EDT2 IGBT and emitter controlled diode in TO247PLUS package

Features

- $V_{CE} = 750\text{ V}$
- $I_C = 120\text{ A}$
- 750 V collector-emitter blocking voltage capability
- Suitable for 470 V V_{DC} systems and increase overvoltage margin for 400 V V_{DC} systems
- Very low $V_{CE(sat)}$, 1.30 V at $I_{Cnom} = 120\text{ A}$, 25°C
- Short circuit robust $t_{sc} = 5\text{ }\mu\text{s}$ at $V_{CE} = 470\text{ V}$, $V_{GE} = 15\text{ V}$
- Self limiting current under short circuit condition
- Positive thermal coefficient and very tight parameter distribution for easy paralleling
- Drop-in replacement for previous generation devices $I_C = 120\text{ A}$, $T_C = 100^\circ\text{C}$
- Excellent current sharing in parallel operation
- Smooth switching characteristics, low EMI signature
- Low gate charge Q_G
- Simple gate drive design
- Co-packed with fast soft recovery emitter controlled 3 diode
- TO247PLUS package with high creepage distance
- High reliability

Potential applications

- xEV traction inverter
- DC-link discharge switch
- Automotive aux-drives

Product validation

- Qualified for automotive applications
- Qualified according to AEC-Q101

Description

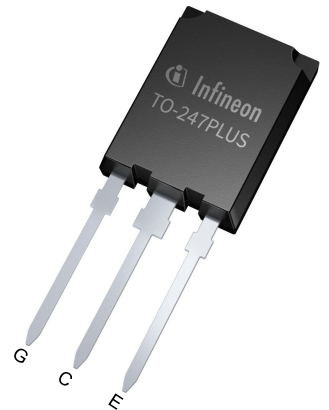
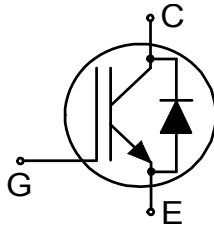

Type	Package	Marking
AIKQ120N75CP2	PG-TO247PLUS-3	AKQ12FCP

Table of contents

	Description	1
	Features	1
	Potential applications	1
	Product validation	1
	Table of contents	2
1	Package	3
2	IGBT	3
3	Diode	5
4	Characteristics diagrams	7
5	Package outlines	14
	Revision history	15
	Disclaimer	16

1 Package

Table 1 Characteristic values

Parameter	Symbol	Note or test condition	Values			Unit
			Min.	Typ.	Max.	
Internal emitter inductance measured 5 mm (0.197 in) from case	L_E			13.0		nH
Storage temperature	T_{stg}		-55		150	°C
Soldering temperature		wave soldering 1.6 mm (0.063 in.) from case for 10 s			260	°C
Thermal resistance, junction-ambient	$R_{th(j-a)}$				40	K/W

2 IGBT

Table 2 Maximum rated values

Parameter	Symbol	Note or test condition	Values	Unit
Collector-emitter voltage	V_{CE}		750	V
DC collector current, limited by T_{vjmax}	I_C	$T_c = 25\text{ °C}$	150	A
		$T_c = 100\text{ °C}$	120	
Pulsed collector current, t_p limited by T_{vjmax}	I_{Cpulse}		360	A
Turn-off safe operating area		$V_{CE} \leq 750\text{ V}$, $t_p = 1\text{ }\mu\text{s}$, $T_{vj} \leq 175\text{ °C}$	360	A
Gate-emitter voltage	V_{GE}		± 20	V
Transient gate-emitter voltage	V_{GE}	$t_p < 0.1\text{ }\mu\text{s}$, $D < 0.01$	± 30	V
Short-circuit withstand time	t_{SC}	$V_{CC} \leq 470\text{ V}$, $V_{GE} = 15\text{ V}$, Allowed number of short circuits < 1000 , Time between short circuits $\geq 1.0\text{ s}$, $T_{vj} = 25\text{ °C}$	5	μs
Power dissipation	P_{tot}	$T_c = 25\text{ °C}$	682	W
		$T_c = 100\text{ °C}$	341	

Table 3 Characteristic values

Parameter	Symbol	Note or test condition	Values			Unit	
			Min.	Typ.	Max.		
Collector-emitter saturation voltage	V_{CEsat}	$I_C = 120\text{ A}$, $V_{GE} = 15\text{ V}$	$T_{vj} = 25\text{ °C}$		1.3	1.5	V
			$T_{vj} = 175\text{ °C}$		1.53		
Gate-emitter threshold voltage	V_{GEth}	$I_C = 1.6\text{ mA}$, $V_{CE} = V_{GE}$, $T_{vj} = 25\text{ °C}$	5	5.8	6.5	V	

(table continues...)

Table 3 (continued) Characteristic values

Parameter	Symbol	Note or test condition	Values			Unit
			Min.	Typ.	Max.	
Zero gate-voltage collector current	I_{CES}	$V_{CE} = 750 \text{ V}, V_{GE} = 0 \text{ V}$	$T_{vj} = 25 \text{ }^\circ\text{C}$		200	μA
			$T_{vj} = 175 \text{ }^\circ\text{C}$		4000	
Gate-emitter leakage current	I_{GES}	$V_{CE} = 0 \text{ V}, V_{GE} = 20 \text{ V}$			100	nA
Transconductance	g_{fs}	$I_C = 120 \text{ A}, V_{CE} = 20 \text{ V}$		90		S
Short-circuit collector current	I_{SC}	$V_{CC} \leq 470 \text{ V}, V_{GE} = 15 \text{ V}, t_{SC} \leq 5 \mu\text{s}$, Allowed number of short circuits < 1000 , Time between short circuits $\geq 1.0 \text{ s}$, $T_{vj} = 25 \text{ }^\circ\text{C}$		750		A
Input capacitance	C_{ies}	$V_{CE} = 25 \text{ V}, V_{GE} = 0 \text{ V}, f = 100 \text{ kHz}$		13125		pF
Output capacitance	C_{oes}	$V_{CE} = 25 \text{ V}, V_{GE} = 0 \text{ V}, f = 100 \text{ kHz}$		337		pF
Reverse transfer capacitance	C_{res}	$V_{CE} = 25 \text{ V}, V_{GE} = 0 \text{ V}, f = 100 \text{ kHz}$		59		pF
Gate charge	Q_G	$I_C = 120 \text{ A}, V_{GE} = 15 \text{ V}, V_{CC} = 600 \text{ V}, V_{CE} = 600 \text{ V}$		731		nC
Turn-on delay time	t_{don}	$V_{CE} = 470 \text{ V}, V_{GE} = -8/15 \text{ V}, R_{Gon} = 5 \Omega, R_{Goff} = 5 \Omega, L_\sigma = 50 \text{ nH}, C_\sigma = 30 \text{ pF}$	$T_{vj} = 25 \text{ }^\circ\text{C}, I_C = 120 \text{ A}$		71	ns
			$T_{vj} = 175 \text{ }^\circ\text{C}, I_C = 120 \text{ A}$		50	
Rise time (inductive load)	t_r	$V_{CE} = 470 \text{ V}, V_{GE} = -8/15 \text{ V}, R_{Gon} = 5 \Omega, R_{Goff} = 5 \Omega, L_\sigma = 50 \text{ nH}, C_\sigma = 30 \text{ pF}$	$T_{vj} = 25 \text{ }^\circ\text{C}, I_C = 120 \text{ A}$		69	ns
			$T_{vj} = 175 \text{ }^\circ\text{C}, I_C = 120 \text{ A}$		68	
Turn-off delay time	t_{doff}	$V_{CE} = 470 \text{ V}, V_{GE} = -8/15 \text{ V}, R_{Gon} = 5 \Omega, R_{Goff} = 5 \Omega, L_\sigma = 50 \text{ nH}, C_\sigma = 30 \text{ pF}$	$T_{vj} = 25 \text{ }^\circ\text{C}, I_C = 120 \text{ A}$		244	ns
			$T_{vj} = 175 \text{ }^\circ\text{C}, I_C = 120 \text{ A}$		226	
Fall time (inductive load)	t_f	$V_{CE} = 470 \text{ V}, V_{GE} = -8/15 \text{ V}, R_{Gon} = 5 \Omega, R_{Goff} = 5 \Omega, L_\sigma = 50 \text{ nH}, C_\sigma = 30 \text{ pF}$	$T_{vj} = 25 \text{ }^\circ\text{C}, I_C = 120 \text{ A}$		50.5	ns
			$T_{vj} = 175 \text{ }^\circ\text{C}, I_C = 120 \text{ A}$		67	
Turn-on energy ¹⁾	E_{on}	$V_{CE} = 470 \text{ V}, V_{GE} = -8/15 \text{ V}, R_{Gon} = 5 \Omega, R_{Goff} = 5 \Omega, L_\sigma = 50 \text{ nH}, C_\sigma = 30 \text{ pF}$	$T_{vj} = 25 \text{ }^\circ\text{C}, I_C = 120 \text{ A}$		6.82	mJ
			$T_{vj} = 175 \text{ }^\circ\text{C}, I_C = 120 \text{ A}$		7.3	
Turn-off energy	E_{off}	$V_{CE} = 470 \text{ V}, V_{GE} = -8/15 \text{ V}, R_{Gon} = 5 \Omega, R_{Goff} = 5 \Omega, L_\sigma = 50 \text{ nH}, C_\sigma = 30 \text{ pF}$	$T_{vj} = 25 \text{ }^\circ\text{C}, I_C = 120 \text{ A}$		3.8	mJ
			$T_{vj} = 175 \text{ }^\circ\text{C}, I_C = 120 \text{ A}$		4.7	

(table continues...)

Table 3 (continued) Characteristic values

Parameter	Symbol	Note or test condition	Values			Unit	
			Min.	Typ.	Max.		
Total switching energy	E_{ts}	$V_{CE} = 470\text{ V}, V_{GE} = -8/15\text{ V},$ $R_{Gon} = 5\ \Omega, R_{Goff} = 5\ \Omega,$ $L_{\sigma} = 50\text{ nH}, C_{\sigma} = 30\text{ pF}$	$T_{vj} = 25\text{ }^{\circ}\text{C},$ $I_C = 120\text{ A}$		10.3		mJ
			$T_{vj} = 175\text{ }^{\circ}\text{C},$ $I_C = 120\text{ A}$		12.1		
IGBT thermal resistance, junction to case ²⁾	R_{thjc}			0.17	0.22	K/W	
Operating junction temperature	T_{vj}		-40		175	$^{\circ}\text{C}$	

1) Includes reverse recovery losses

2) Not subject to production test - specified by simulation.

3 Diode

Table 4 Maximum rated values

Parameter	Symbol	Note or test condition	Values	Unit	
Diode forward current, limited by T_{vjmax}	I_F		$T_c = 25\text{ }^{\circ}\text{C}$	150	A
			$T_c = 100\text{ }^{\circ}\text{C}$	120	
Diode pulsed current, limited by T_{vjmax}	I_{Fpulse}		360	A	
Power dissipation	P_{tot}		$T_c = 25\text{ }^{\circ}\text{C}$	375	W
			$T_c = 100\text{ }^{\circ}\text{C}$	170	

Table 5 Characteristic values

Parameter	Symbol	Note or test condition	Values			Unit	
			Min.	Typ.	Max.		
Diode forward voltage	V_F	$I_F = 120\text{ A}$	$T_{vj} = 25\text{ }^{\circ}\text{C}$		1.7	1.95	V
			$T_{vj} = 175\text{ }^{\circ}\text{C}$		1.74		
Diode reverse recovery charge	Q_{rr}	$V_R < 470\text{ V}, R_{Gon} = 4.8\ \Omega$	$T_{vj} = 25\text{ }^{\circ}\text{C},$ $I_F = 120\text{ A},$ $-di_F/dt = 1070\text{ A}/\mu\text{s}$		3.6		μC
			$T_{vj} = 175\text{ }^{\circ}\text{C},$ $I_F = 120\text{ A},$ $-di_F/dt = 1055\text{ A}/\mu\text{s}$		5.3		

(table continues...)

Table 5 (continued) Characteristic values

Parameter	Symbol	Note or test condition	Values			Unit	
			Min.	Typ.	Max.		
Diode peak reverse recovery current	I_{rrm}	$V_R < 470 \text{ V}$, $R_{Gon} = 4.8 \Omega$	$T_{vj} = 25 \text{ }^\circ\text{C}$, $I_F = 120 \text{ A}$, $-di_F/dt = 1070 \text{ A}/\mu\text{s}$		33		A
			$T_{vj} = 175 \text{ }^\circ\text{C}$, $I_F = 120 \text{ A}$, $-di_F/dt = 1055 \text{ A}/\mu\text{s}$		43		
Reverse recovery energy	E_{rec}	$V_R < 470 \text{ V}$, $V_{GE} = -8/15 \text{ V}$, $R_{Gon} = 4.8 \Omega$, $L_\sigma = 50 \text{ nH}$, $C_\sigma = 30 \text{ pF}$	$T_{vj} = 25 \text{ }^\circ\text{C}$, $I_F = 120 \text{ A}$, $-di_F/dt = 1070 \text{ A}/\mu\text{s}$		1.2		mJ
			$T_{vj} = 175 \text{ }^\circ\text{C}$, $I_F = 120 \text{ A}$, $-di_F/dt = 1055 \text{ A}/\mu\text{s}$		1.6		
Diode thermal resistance, junction to case ¹⁾	R_{thjc}			0.31	0.4		K/W
Operating junction temperature	T_{vj}		-40		175		$^\circ\text{C}$

¹⁾ Note subject to test

4 Characteristics diagrams

Power dissipation as a function of case temperature, IGBT

$P_{tot} = f(T_c)$
 $T_{vj} \leq 175\text{ }^\circ\text{C}$

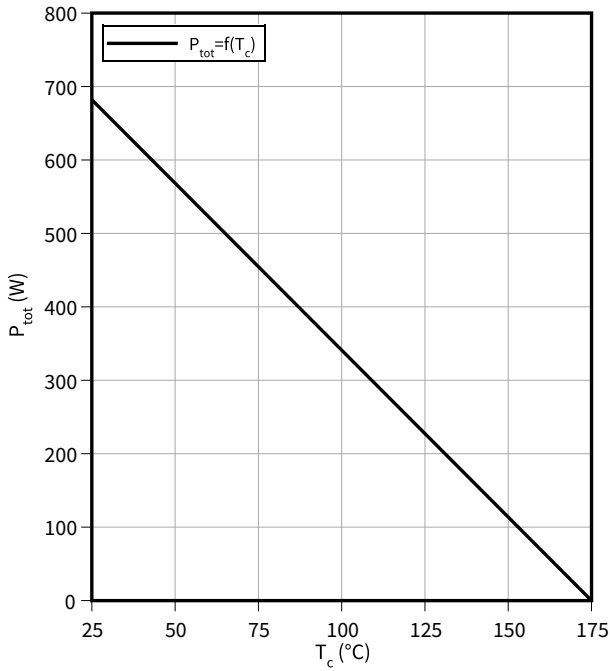

Collector current as a function of case temperature, IGBT

$I_C = f(T_c)$
 $T_{vj} \leq 175\text{ }^\circ\text{C}, V_{GE} = 15\text{ V}$

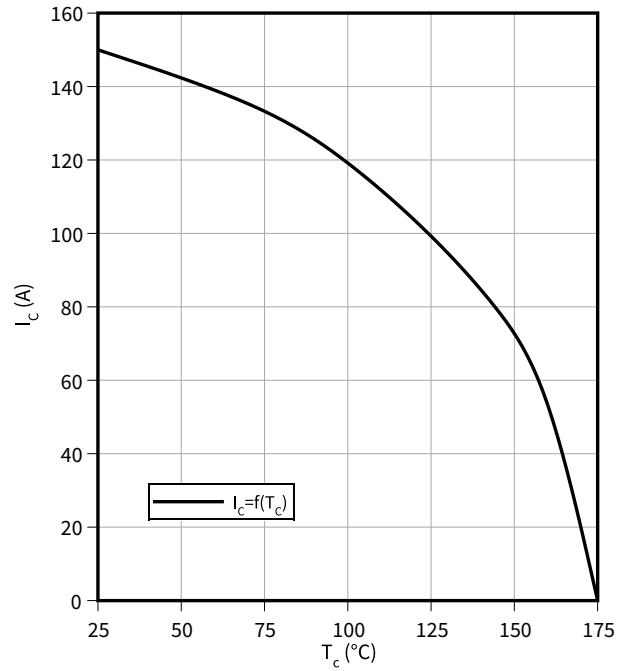

Typical output characteristic, IGBT

$I_C = f(V_{CE})$
 $T_{vj} = 25\text{ }^\circ\text{C}$

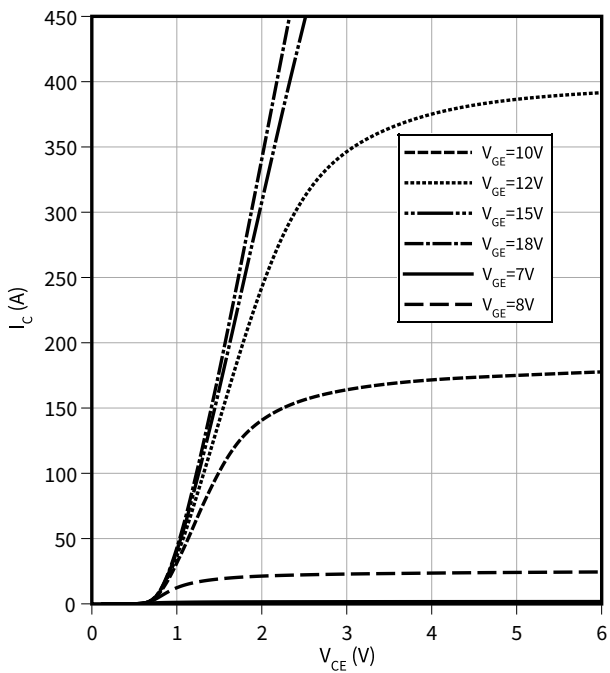

Typical output characteristic, IGBT

$I_C = f(V_{CE})$
 $T_{vj} = 175\text{ }^\circ\text{C}$

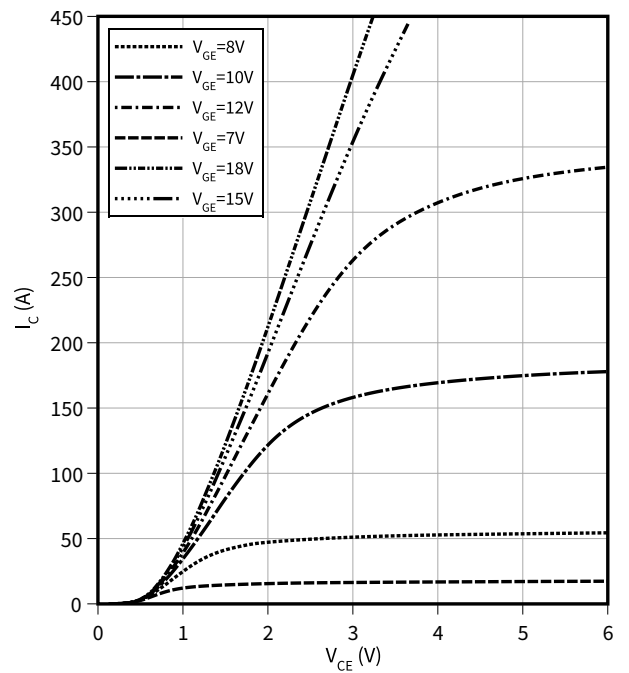

4 Characteristics diagrams

Typical transfer characteristic, IGBT

$I_C = f(V_{GE})$
 $V_{CE} = 20\text{ V}$

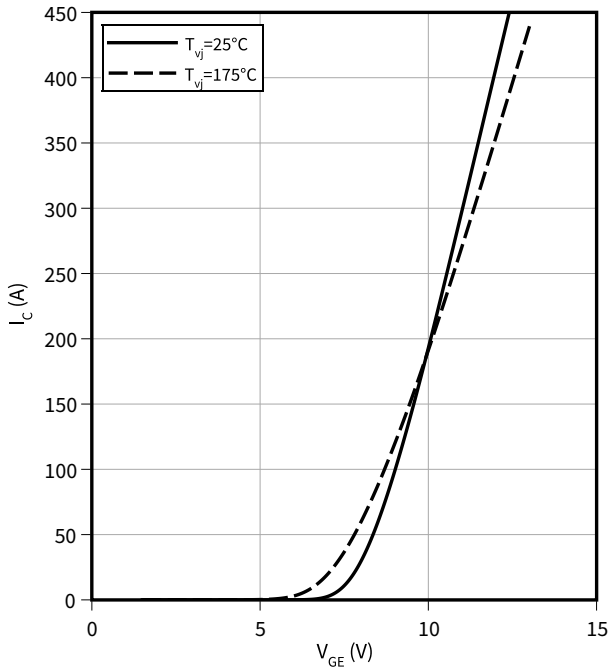

Typical collector-emitter saturation voltage as a function of junction temperature, IGBT

$V_{CEsat} = f(T_{vj})$
 $V_{GE} = 15\text{ V}$

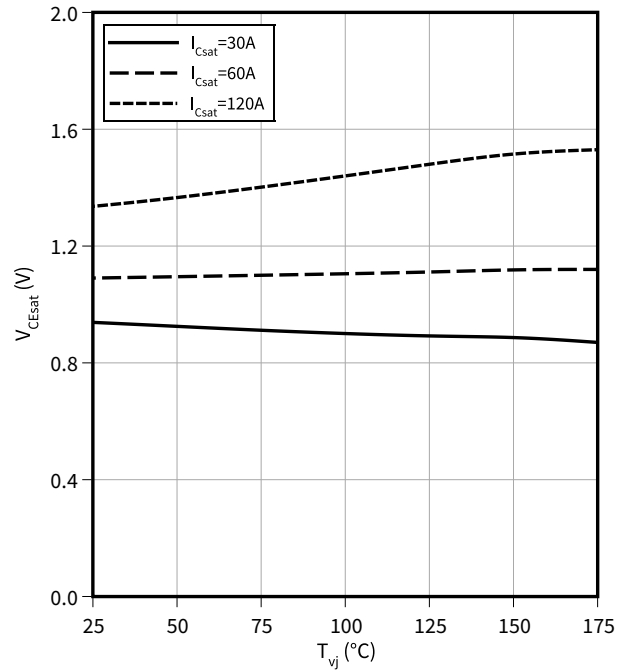

Typical switching times as a function of collector current, IGBT

$t = f(I_C)$
 $R_{Goff} = 5.0\ \Omega$, $V_{CE} = 470\text{ V}$, $T_{vj} = 175^\circ\text{C}$, $V_{GE} = -8/15\text{ V}$, $R_{Gon} = 5\ \Omega$

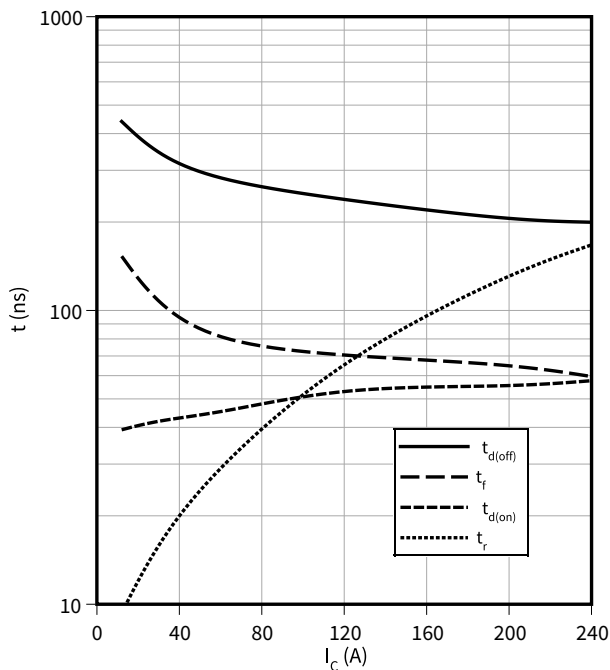

Typical switching times as a function of gate resistor, IGBT

$t = f(R_G)$
 $I_C = 120.0\text{ A}$, $V_{CE} = 470\text{ V}$, $T_{vj} = 175^\circ\text{C}$, $V_{GE} = -8/15\text{ V}$

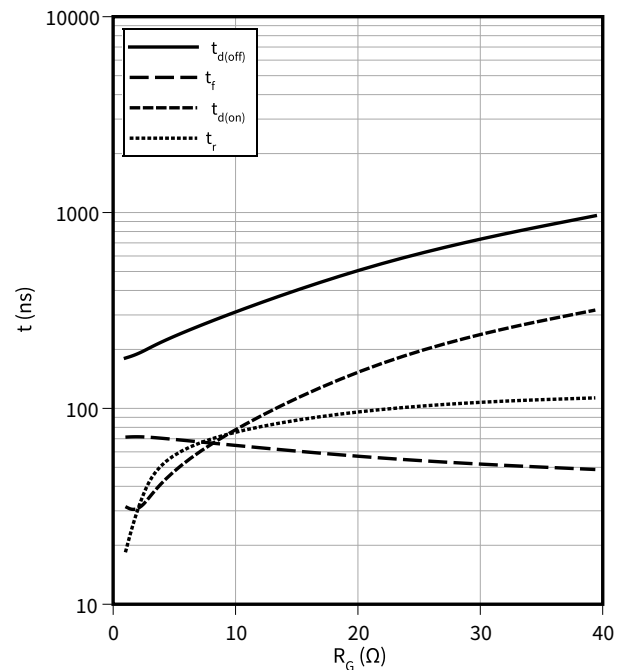

Typical switching times as a function of junction temperature, IGBT

$t = f(T_{vj})$

$I_C = 120.0 \text{ A}$, $R_{Goff} = 5.0 \text{ } \Omega$, $V_{CE} = 470 \text{ V}$, $V_{GE} = -8/15 \text{ V}$, $R_{Gon} = 5 \text{ } \Omega$

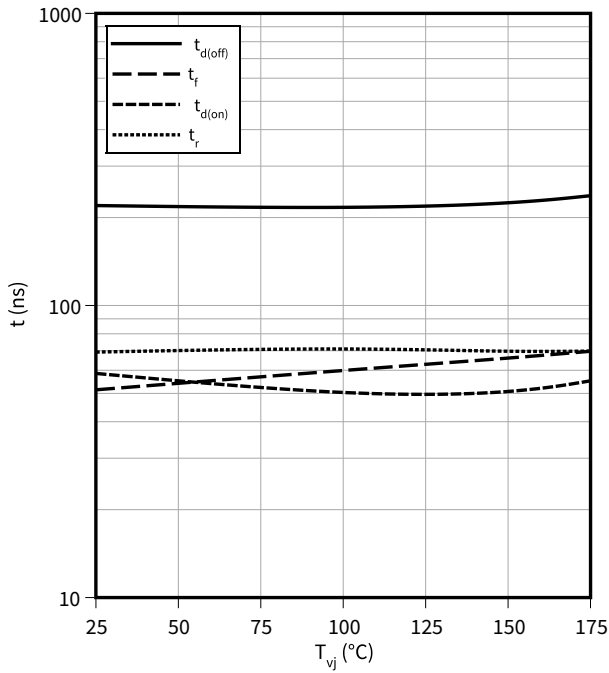

Typical Gate-emitter threshold voltage as a function of junction temperature, IGBT

$V_{GEth} = f(T_{vj})$

$I_C = 1.60 \text{ mA}$

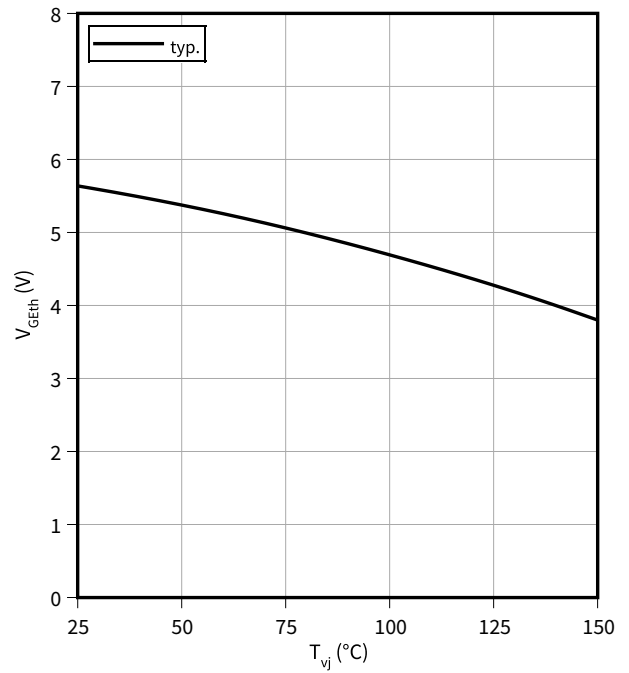

Typical switching energy losses as a function of gate resistor, IGBT

$E = f(R_G)$

$I_C = 120.0 \text{ A}$, $V_{CE} = 470 \text{ V}$, $T_{vj} = 175 \text{ } ^\circ\text{C}$, $V_{GE} = -8/15 \text{ V}$

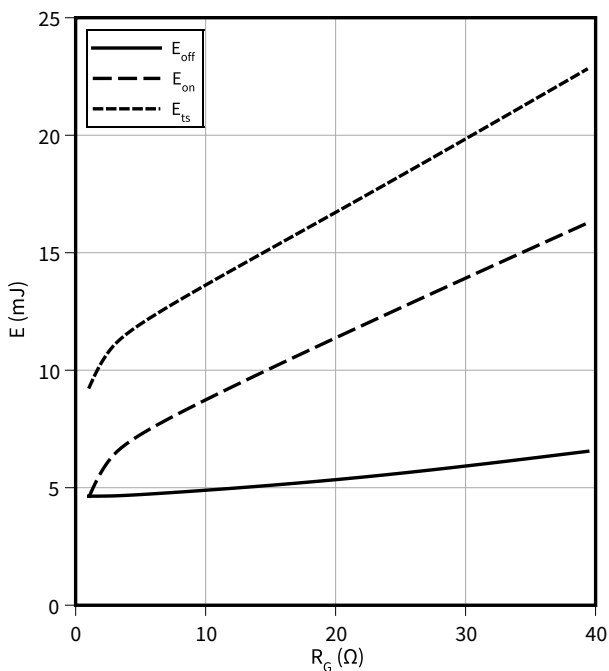

Typical switching energy losses as a function of collector current, IGBT

$E = f(I_C)$

$R_{Goff} = 5.0 \text{ } \Omega$, $V_{CE} = 470 \text{ V}$, $T_{vj} = 175 \text{ } ^\circ\text{C}$, $V_{GE} = -8/15 \text{ V}$, $R_{Gon} = 5 \text{ } \Omega$

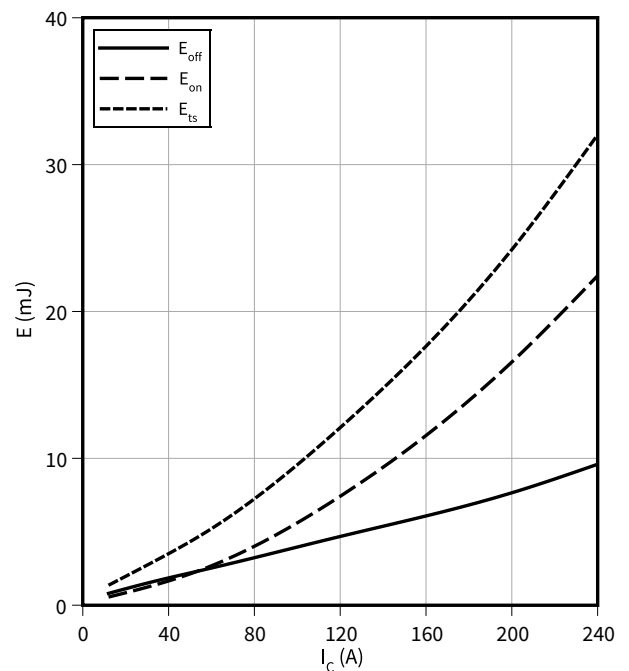

4 Characteristics diagrams

Typical switching energy losses as a function of junction temperature, IGBT

$E = f(T_{vj})$

$I_C = 120.0 \text{ A}$, $R_{Goff} = 5.0 \text{ } \Omega$, $V_{CE} = 470 \text{ V}$, $V_{GE} = -8/15 \text{ V}$, $R_{Gon} = 5 \text{ } \Omega$

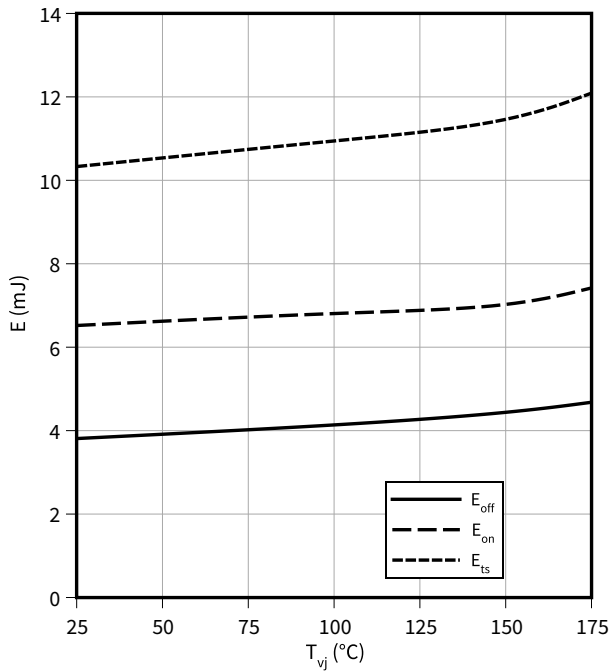

Typical switching energy losses as a function of collector emitter voltage, IGBT

$E = f(V_{CE})$

$I_C = 120 \text{ A}$, $R_{Goff} = 5 \text{ } \Omega$, $T_{vj} \leq 175 \text{ } ^\circ\text{C}$, $V_{GE} = -8/15 \text{ V}$, $R_{Gon} = 5 \text{ } \Omega$

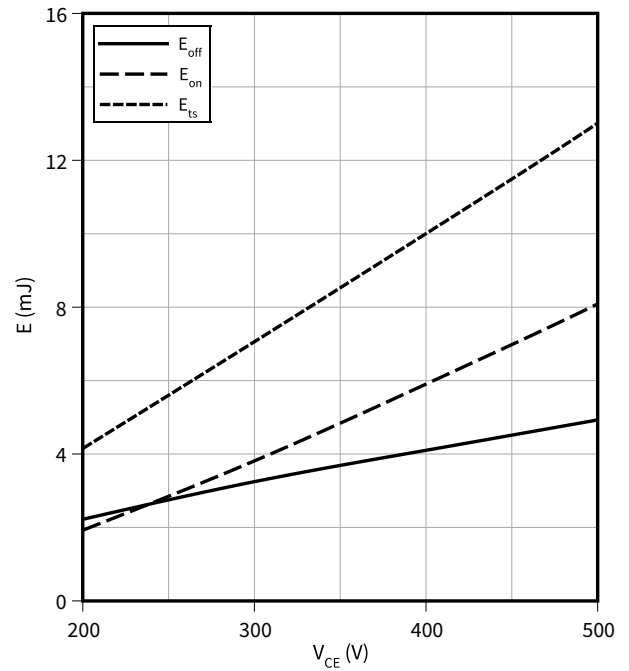

Typical capacitance as a function of collector-emitter voltage, IGBT

$C = f(V_{CE})$

$f = 100 \text{ kHz}$, $V_{GE} = 0 \text{ V}$

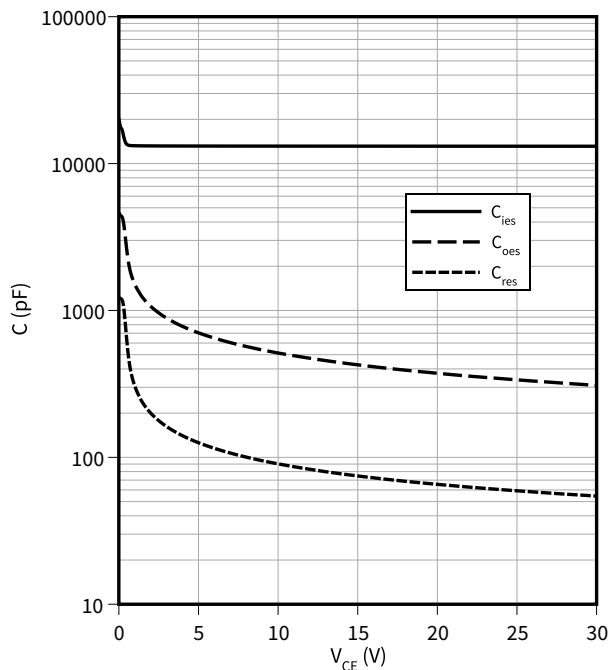

Typical gate charge, IGBT

$V_{GE} = f(Q_{GE})$

$I_C = 120.0 \text{ A}$

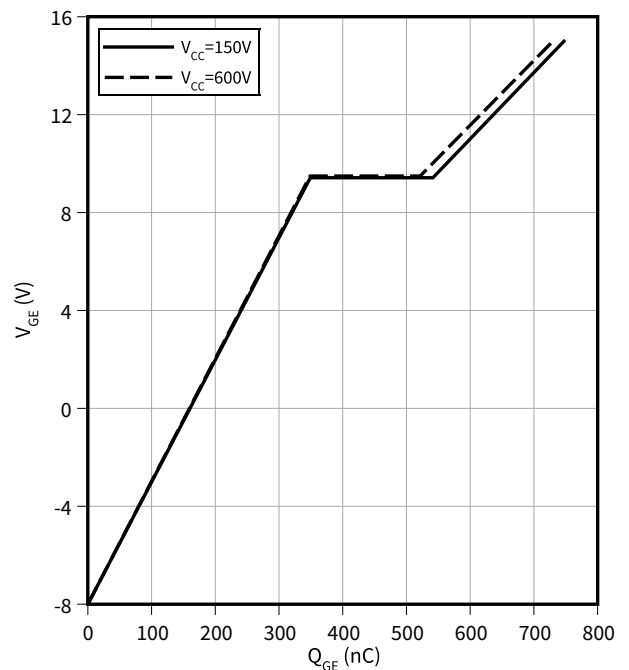

4 Characteristics diagrams

Typical Short circuit withstand time as a function of gate-emitter voltage, IGBT

$t_{SC} = f(V_{GE})$
 $T_{vj} \leq 175\text{ }^\circ\text{C}, V_{CC} \leq 470\text{ V}$

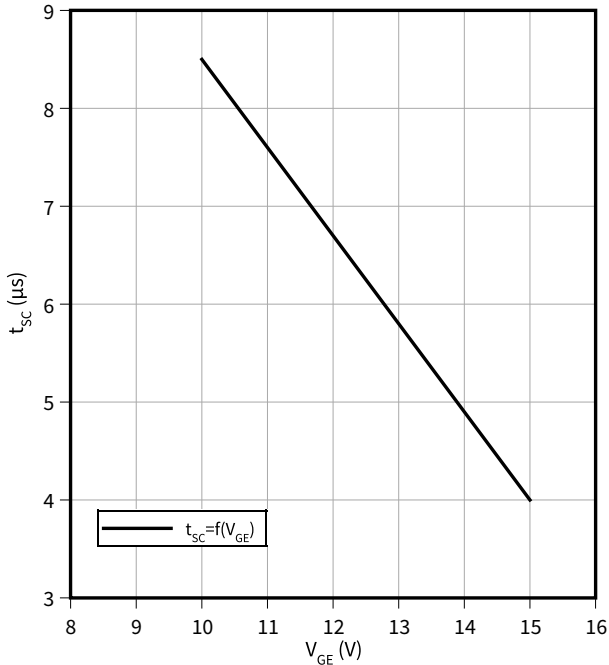

Typical short circuit collector current as a function of gate-emitter voltage, IGBT

$I_{C(SC)} = f(V_{GE})$
 $T_{vj} \leq 175\text{ }^\circ\text{C}, V_{CC} \leq 470\text{ V}$

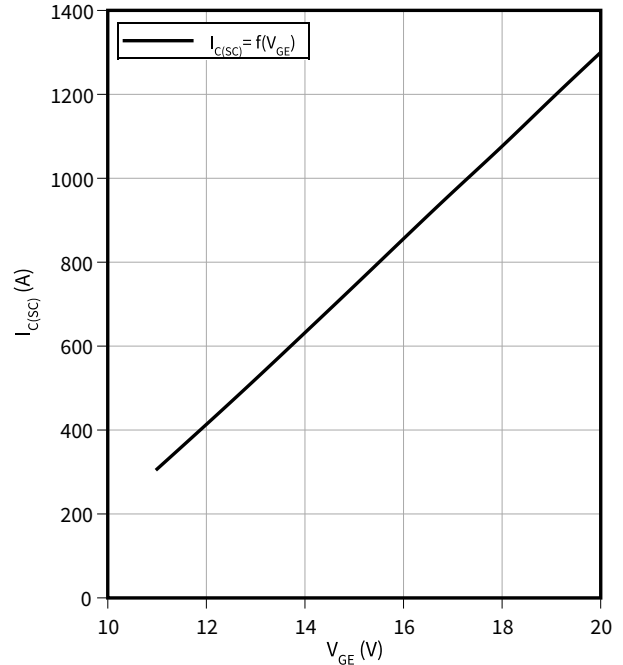

IGBT transient thermal impedance as a function of pulse width, IGBT

$Z_{th} = f(t_p)$
 $D = t_p/T$

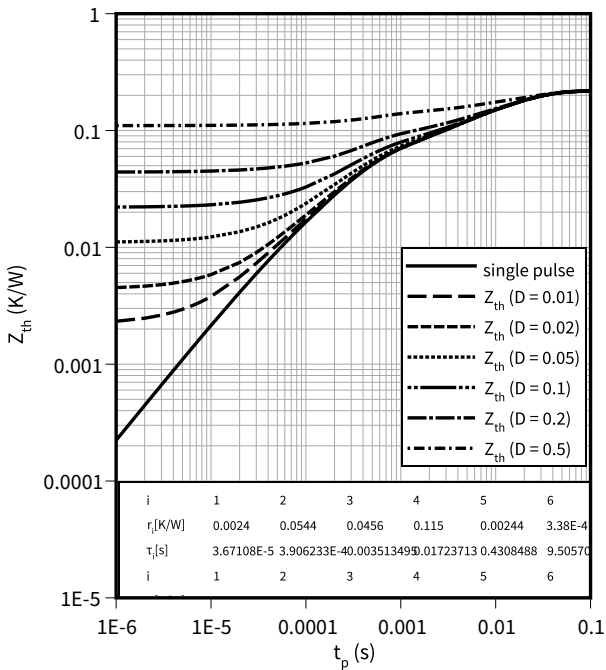

Diode transient thermal impedance as a function of pulse width, Diode

$Z_{th} = f(t_p)$
 $D = t_p/T$

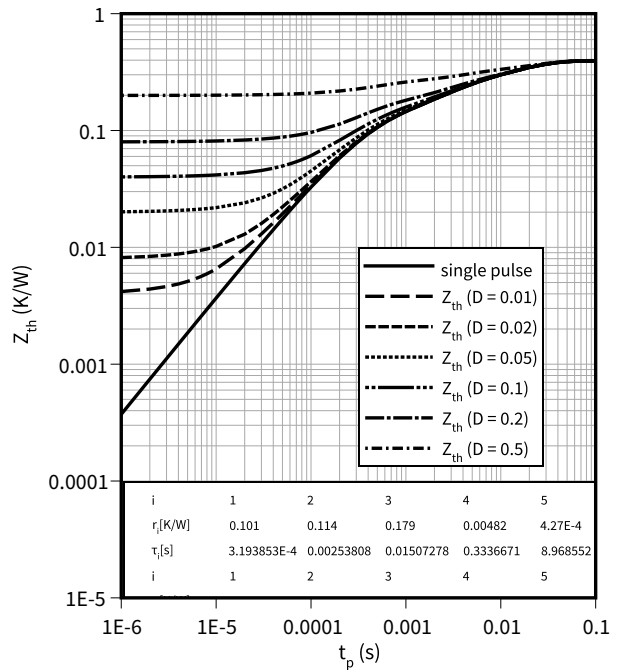

4 Characteristics diagrams

Typical reverse recovery time as a function of diode current slope, Diode

$t_{rr} = f(di_F/dt)$

$V_R = 470 \text{ V}, I_F = 120.0 \text{ A}$

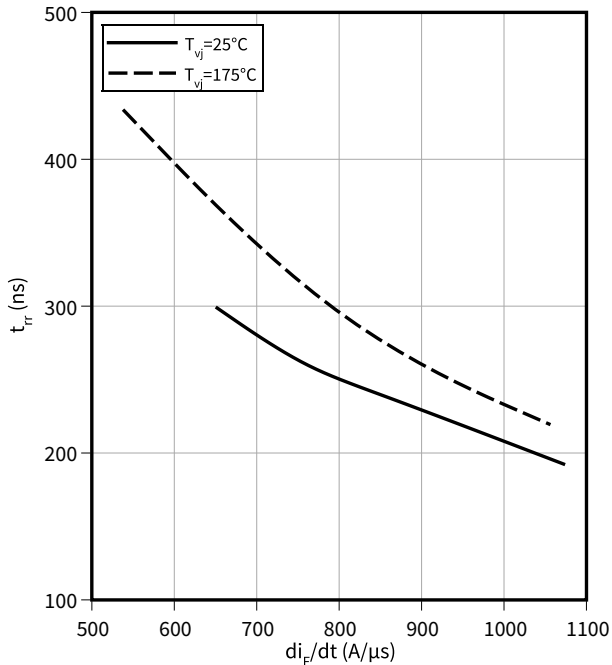

Typical reverse recovery charge as a function of diode current slope, Diode

$Q_{rr} = f(di_F/dt)$

$V_R = 470 \text{ V}, I_F = 120.0 \text{ A}$

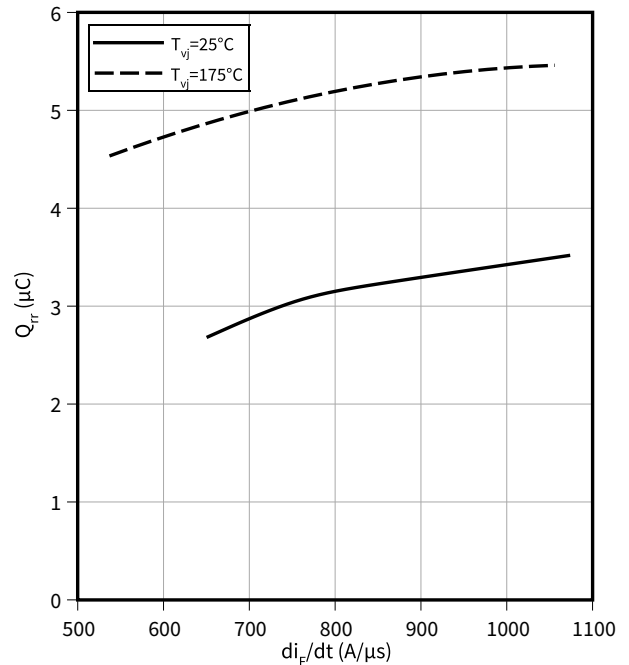

Typical reverse recovery current as a function of diode current slope, Diode

$I_{rr} = f(di_F/dt)$

$V_R = 470 \text{ V}, I_F = 120.0 \text{ A}$

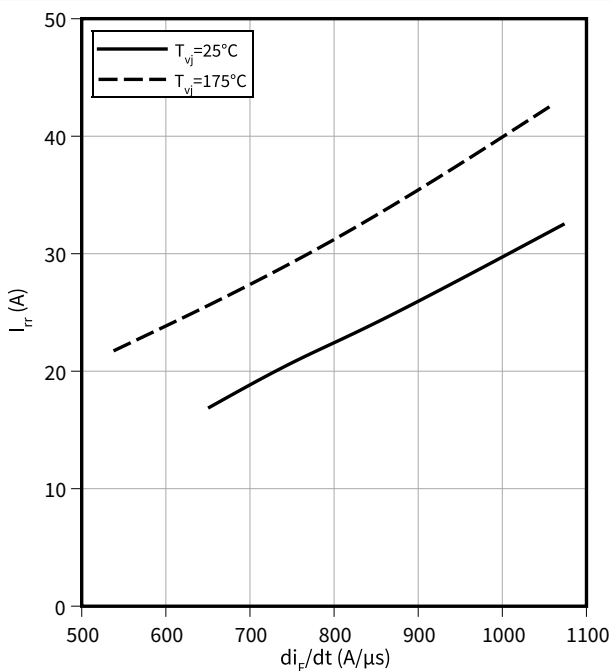

Typical diode peak rate of fall of reverse recovery current as a function of diode current slope, Diode

$dI_{rr}/dt = f(di_F/dt)$

$V_R = 470 \text{ V}, I_F = 120.0 \text{ A}$

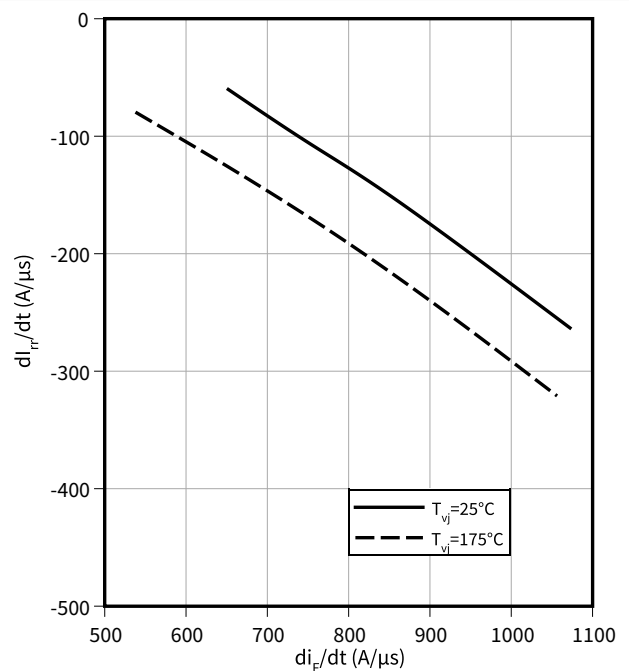

Typical diode forward voltage as a function of junction temperature, Diode

$V_F = f(T_{vj})$

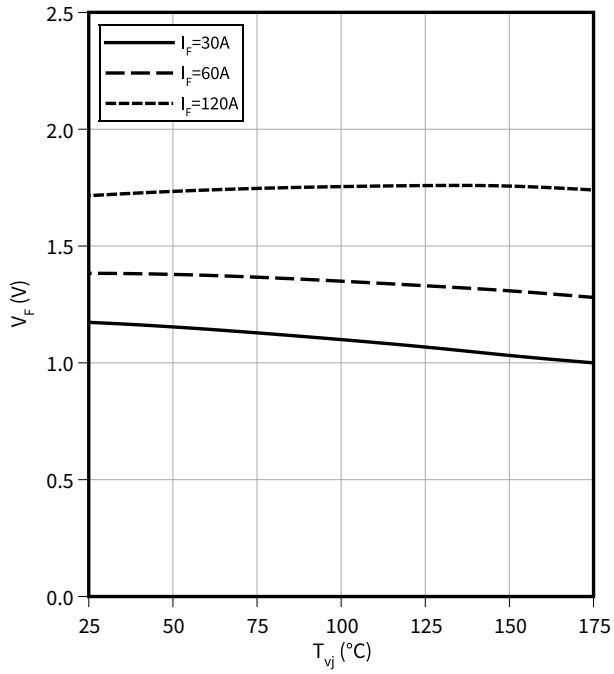

Typical diode forward current as a function of forward voltage, Diode

$I_F = f(V_F)$

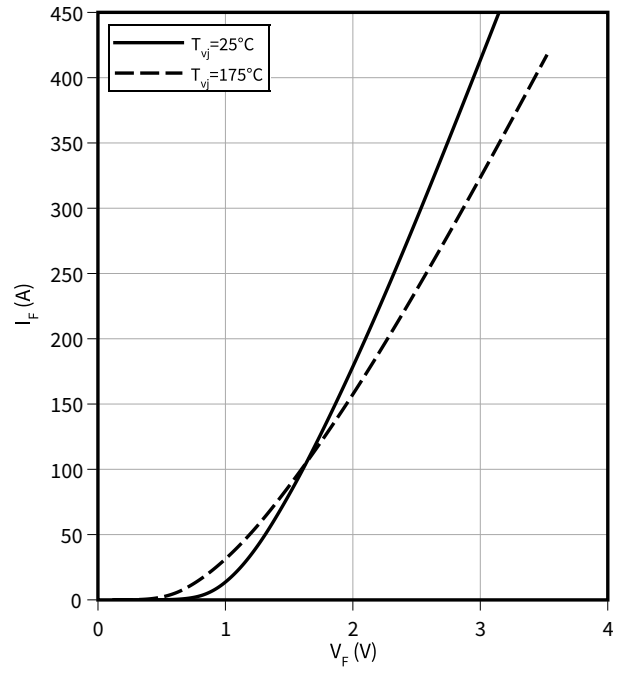

5 Package outlines

Package Drawing PG-TO247PLUS-3

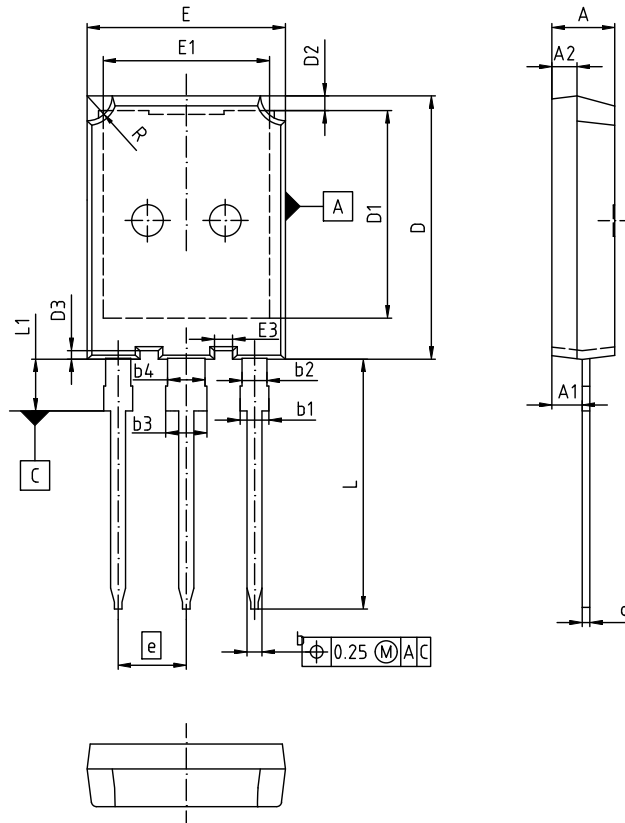

DIM	MILLIMETERS		INCHES	
	MIN	MAX	MIN	MAX
A	4.90	5.10	0.193	0.201
A1	2.31	2.51	0.091	0.099
A2	1.90	2.10	0.075	0.083
b	1.16	1.26	0.046	0.050
b1	1.96	2.25	0.077	0.089
b2	1.96	2.06	0.077	0.081
c	0.59	0.66	0.023	0.026
D	20.90	21.10	0.823	0.831
D1	16.25	16.85	0.640	0.663
D2	1.05	1.35	0.041	0.053
D3	0.58	0.78	0.023	0.031
E	15.70	15.90	0.618	0.626
E1	13.10	13.50	0.516	0.531
E3	1.35	1.55	0.053	0.061
e	5.44 (BSC)		0.214 (BSC)	
N	3		3	
L	19.80	20.10	0.780	0.791
L1	-	4.30	-	0.169
R	1.90	2.10	0.075	0.083

DOCUMENT NO.
Z8B00174295

SCALE

EUROPEAN PROJECTION

ISSUE DATE
13-08-2014

REVISION
01

Figure 1

Revision history

Document revision	Date of release	Description of changes
1.00	2022-02-16	Final datasheet
1.10	2022-03-16	Updated VF and Rthjc