

High-performance motion sensor for automotive applications: ultra-low-power digital output 3-axis accelerometer

Datasheet - production data

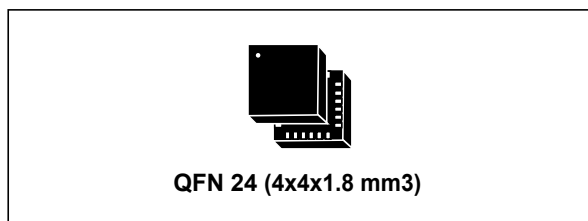

Features

- Wide supply voltage range: 2.4 V to 3.6 V
- 1.8 V low voltage compatible IOs
- Ultra-low-power mode consumption down to 10 μ A
- $\pm 6g/\pm 12g/\pm 24g$ dynamically selectable full scale
- SPI/I²C digital output interface
- 16-bit data output, 12-bit resolution
- 2 independent programmable interrupt generators
- System sleep-to-wake function
- Embedded self-test
- Extended temperature range -40°C to 105°C
- 10000 g high shock survivability
- ECOPACK[®], RoHS and “Green” compliant (see [Section 8](#))
- AEC-Q100 qualification

Description

The AIS3624DQ is an ultra-low-power high-performance three-axis accelerometer with a digital serial interface SPI standard output, an I²C compatible interface is also available.

The device features ultra-low-power operational modes that allow advanced power saving and smart sleep-to-wake functions.

The AIS3624DQ has dynamically user selectable full scales of $\pm 6g/\pm 12g/\pm 24g$ and it is capable of measuring accelerations with output data rates from 0.5 Hz to 1 kHz.

The self-test capability allows the user to check the functioning of the sensor in the final application.

The device may be configured to generate an interrupt signal by inertial wakeup/free-fall events as well as by the position of the device itself. Thresholds and timing of interrupt generators are programmable by the end user on the fly.

The AIS3624DQ is available in small, quad flat no-lead package (QFN) with the reduced 4x4 mm footprint required by many applications and it is guaranteed to operate over an extended temperature range from -40 °C to +105 °C.

This product may be used in a variety of automotive non-safety applications such as:

- Motion-activated functions
- Telematic boxes
- Impact recognition and logging systems
- Vibration monitoring and compensation

Table 1. Device summary

Order codes	Temperature range [°C]	Package	Packaging
AIS3624DQ	-40 to +105	QFN 4x4x1.8 24L	Tray
AIS3624DQTR	-40 to +105	QFN 4x4x1.8 24L	Tape and reel

Contents

1	Block diagram and pin description	8
1.1	Block diagram	8
1.2	Pin description	8
2	Mechanical and electrical specifications	10
2.1	Mechanical characteristics	10
2.2	Electrical characteristics	11
2.3	Communication interface characteristics	12
2.3.1	SPI - serial peripheral interface	12
2.3.2	I ² C - inter-IC control interface	13
2.4	Absolute maximum ratings	14
2.5	Terminology	15
2.5.1	Sensitivity	15
2.5.2	Zero-g level	15
2.5.3	Self-test	15
2.5.4	Sleep-to-wake	15
3	Functionality	16
3.1	Sensing element	16
3.2	IC interface	16
3.3	Factory calibration	16
4	Application hints	17
4.1	Soldering information	17
5	Digital interfaces	18
5.1	I2C serial interface	18
5.1.1	I2C operation	19
5.2	SPI bus interface	20
5.2.1	SPI read	21
5.2.2	SPI write	22
5.2.3	SPI read in 3-wire mode	23

6	Register mapping	24
7	Register description	25
7.1	WHO_AM_I (0Fh)	25
7.2	CTRL_REG1 (20h)	25
7.3	CTRL_REG2 (21h)	26
7.4	CTRL_REG3 [interrupt CTRL register] (22h)	27
7.5	CTRL_REG4 (23h)	28
7.6	CTRL_REG5 (24h)	29
7.7	HP_FILTER_RESET (25h)	29
7.8	REFERENCE (26h)	30
7.9	STATUS_REG (27h)	30
7.10	OUT_X_L (28h), OUT_X_H (29)	31
7.11	OUT_Y_L (2Ah), OUT_Y_H (2Bh)	31
7.12	OUT_Z_L (2Ch), OUT_Z_H (2Dh)	31
7.13	INT1_CFG (30h)	31
7.14	INT1_SRC (31h)	32
7.15	INT1_THS (32h)	32
7.16	INT1_DURATION (33h)	33
7.17	INT2_CFG (34h)	33
7.18	INT2_SRC (35h)	34
7.19	INT2_THS (36h)	34
7.20	INT2_DURATION (37h)	35
8	Package information	36
8.1	QFN 24L package information	36
9	Soldering information	37
9.1	General guidelines for soldering surface-mount MEMS sensors	37
9.2	PCB design guidelines	37
9.3	PCB design rules	38
9.4	Stencil design and solder paste application	38
9.5	Process considerations	39

10 **Revision history** **40**

List of tables

Table 1.	Device summary	1
Table 2.	Pin description	9
Table 3.	Mechanical characteristics @ Vdd = 3.3 V, T = -40 °C to +105 °C unless otherwise noted	10
Table 4.	Electrical characteristics @ Vdd = 3.3 V, T = -40 °C to +105 °C unless otherwise noted .	11
Table 5.	SPI slave timing values	12
Table 6.	I ² C slave timing values	13
Table 7.	Absolute maximum ratings	14
Table 8.	Serial interface pin description	18
Table 9.	I ² C terminology	18
Table 10.	SAD+Read/Write patterns	19
Table 11.	Transfer when master is writing one byte to slave	19
Table 12.	Transfer when master is writing multiple bytes to slave:	19
Table 13.	Transfer when master is receiving (reading) one byte of data from slave:	20
Table 14.	Transfer when master is receiving (reading) multiple bytes of data from slave	20
Table 15.	Register address map	24
Table 16.	WHO_AM_I register	25
Table 17.	CTRL_REG1 register	25
Table 18.	CTRL_REG1 description	25
Table 19.	Power mode and low-power output data rate configurations	26
Table 20.	Normal-mode output data rate configurations and low-pass cutoff frequencies	26
Table 21.	CTRL_REG2 register	26
Table 22.	CTRL_REG2 description	26
Table 23.	High-pass filter mode configuration	27
Table 24.	High-pass filter cutoff frequency configuration	27
Table 25.	CTRL_REG3 register	27
Table 26.	CTRL_REG3 description	28
Table 27.	Data signal on INT 1 and INT 2 pads	28
Table 28.	CTRL_REG4 register	28
Table 29.	CTRL_REG4 description	28
Table 30.	CTRL_REG5 register	29
Table 31.	CTRL_REG5 description	29
Table 32.	Sleep-to-wake configuration	29
Table 33.	REFERENCE register	30
Table 34.	REFERENCE description	30
Table 35.	STATUS_REG register	30
Table 36.	STATUS_REG description	30
Table 37.	INT1_CFG register	31
Table 38.	INT1_CFG description	31
Table 39.	Interrupt 1 source configurations	32
Table 40.	INT1_SRC register	32
Table 41.	INT1_SRC description	32
Table 42.	INT1_THS register	32
Table 43.	INT1_THS description	32
Table 44.	INT1_DURATION register	33
Table 45.	INT2_DURATION description	33
Table 46.	INT2_CFG register	33
Table 47.	INT2_CFG description	33

Table 48.	Interrupt mode configuration	34
Table 49.	INT2_SRC register	34
Table 50.	INT2_SRC description	34
Table 51.	INT2_THS register	34
Table 52.	INT2_THS description	34
Table 53.	INT2_DURATION register	35
Table 54.	INT2_DURATION description	35
Table 55.	Document revision history	40

List of figures

Figure 1.	Block diagram	8
Figure 2.	Pin connections	8
Figure 3.	SPI slave timing diagram (2).	12
Figure 4.	I ² C slave timing diagram.	13
Figure 5.	AIS3624DQ electrical connections	17
Figure 6.	Read and write protocol	20
Figure 7.	SPI read protocol	21
Figure 8.	Multiple byte SPI read protocol (2-byte example).	22
Figure 9.	SPI write protocol	22
Figure 10.	Multiple byte SPI write protocol (2-byte example).	22
Figure 11.	SPI read protocol in 3-wire mode	23
Figure 12.	QFN 24L: Mechanical data and package outline	36
Figure 13.	Recommended land and solder mask design for QFPN packages	38

1 Block diagram and pin description

1.1 Block diagram

Figure 1. Block diagram

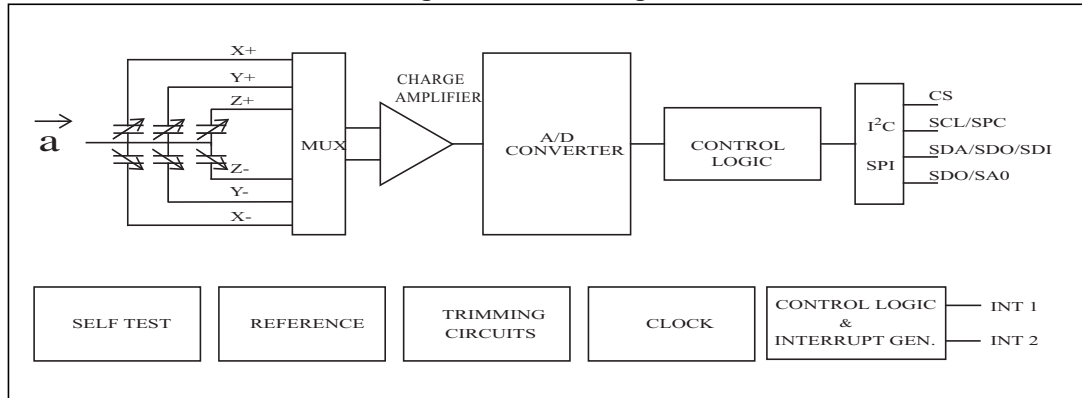

1.2 Pin description

Figure 2. Pin connections

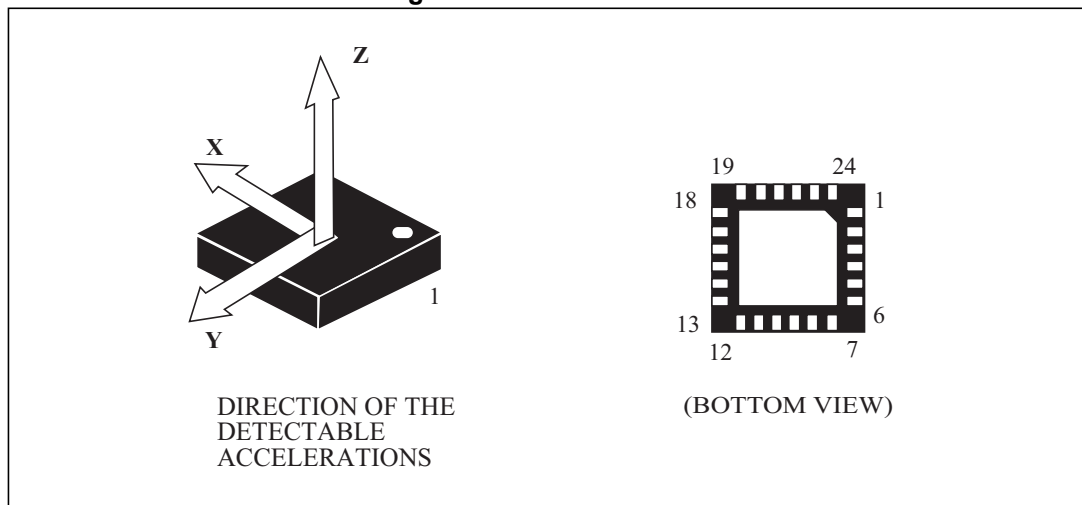

Table 2. Pin description

Pin#	Name	Function
1,2	NC	Not connected
3	INT_2	Inertial interrupt 2
4	Reserved	Connect to GND
5	VDD	Power supply
6	GND	0 V supply
7	INT_1	Inertial interrupt 1
8	GND	0 V supply
9	GND	0 V supply
10	GND	0 V supply
11	SPC SCL	SPI serial port clock (SPC) I ² C serial clock (SCL)
12	CS	SPI enable I ² C/SPI mode selection (0: SPI enabled; 1: I ² C mode)
13	Reserved	Connect to Vdd
14	VDD_IO	Power supply for I/O pins
15	SDO SA0	SPI serial data output (SDO) I ² C less significant bit of the device address (SA0)
16	SDI SDO SDA	SPI serial data input (SDI) 3-wire interface serial data output (SDO) I ² C serial data (SDA)
17-24	NC	Not internally connected

2 Mechanical and electrical specifications

2.1 Mechanical characteristics

Table 3. Mechanical characteristics @ Vdd = 3.3 V, T = -40 °C to +105 °C unless otherwise noted ⁽¹⁾

Symbol	Parameter	Test conditions	Min.	Typ.	Max.	Unit
FS	Measurement range ⁽²⁾	FS bit set to 00		±6		g
		FS bit set to 01		±12		
		FS bit set to 11		±24		
So	Sensitivity	FS bit set to 00 12-bit representation	2.55	2.9	3.25	mg/digit
		FS bit set to 01 12-bit representation	5.19	5.9	6.61	
		FS bit set to 11 12-bit representation	10.29	11.7	13.11	
Off	Zero-g level offset accuracy ^{(3),(4),(5)}	X, Y axes	-500		500	mg
		Z-axis	-950		950	
TyOff	Typical zero-g level offset accuracy ^{(6),(7)}	FS bit set to 00	-90	±70	90	mg
TCOff	Zero-g level change vs temperature	Max delta from 25 °C (X, Y axes)	-5	±0.4	5	mg/°C
		Max delta from 25 °C (Z-axis)	-11.25		11.25	
An	Acceleration noise density	FS bit set to 00		600	1500	µg/√Hz
Vst	Self-test output change ^{(8),(9),(10)}	FS bit set to 00 X-axis	-40	-270	-500	LSb
		FS bit set to 00 Y-axis	40	270	500	LSb
		FS bit set to 00 Z-axis	120	510	900	LSb
Top	Operating temperature range		-40		+105	°C
Wh	Product weight			55		mgram

- The product is factory calibrated at 3.3 V. Operational power supply (Vdd) over 3.6 V it is not recommended.
- Verified by wafer level test and measurement of initial offset and sensitivity
- Typical zero-g level offset value after MSL3 preconditioning
- Offset can be eliminated by enabling the built-in high-pass filter
- Typical zero-g level offset value after MSL3 preconditioning
- Typical zero-g level offset value after MSL3 preconditioning
- Offset can be eliminated by enabling the built-in high-pass filter
- The sign of "Self-test output change" is defined by a sign bit, for all axes.
- Self-test output changes with the power supply. "Self-test output change" is defined as $OUTPUT[LSb]_{(CTRL_REG4\ ST\ bit=1)} - OUTPUT[LSb]_{(CTRL_REG4\ ST\ bit=0)}$. 1LSb=12g/4096 at 12-bit representation, ±6 g full scale
- Output data reach 99% of final value after 1/ODR+1ms when enabling self-test mode, due to device filtering

2.2 Electrical characteristics

Table 4. Electrical characteristics @ Vdd = 3.3 V, T = -40 °C to +105 °C unless otherwise noted ⁽¹⁾

Symbol	Parameter	Test conditions	Min.	Typ.	Max.	Unit
Vdd	Supply voltage		2.4	3.3	3.6	V
Vdd_IO	I/O pins supply voltage ⁽²⁾		1.8		Vdd+0.1	V
Idd	Current consumption in normal mode	2.4 V to 3.6 V	200		450	μA
IddLP	Current consumption in low-power mode	ODR=1 Hz, BW=500 Hz, T=25°C	8	10	12	μA
IddPdn	Current consumption in power-down mode		0.1	1	2	μA
VIH	Digital high-level input voltage		0.8*Vdd_IO			V
VIL	Digital low-level input voltage				0.2*Vdd_IO	V
VOH	High-level output voltage		0.9*Vdd_IO			V
VOL	Low-level output voltage				0.1*Vdd_IO	V
ODR	Output data rate in normal mode	DR bit set to 00		50		Hz
		DR bit set to 01		100		
		DR bit set to 10		400		
		DR bit set to 11		1000		
ODR _{LP}	Output data rate in low-power mode	PM bit set to 010		0.5		Hz
		PM bit set to 011		1		
		PM bit set to 100		2		
		PM bit set to 101		5		
		PM bit set to 110		10		
BW	System bandwidth			ODR/2		Hz
Ton	Turn-on time ⁽³⁾	ODR = 100 Hz	0.9/ODR+ 1 ms	1/ODR+ 1 ms	1.1/ODR+ 1 ms	s
Top	Operating temperature range		-40		+105	°C

1. The product is factory calibrated at 3.3 V. Operational power supply (Vdd) over 3.6 V is not recommended.
2. It is possible to remove Vdd maintaining Vdd_IO without blocking the communication busses, in this condition the measurement chain is powered off.
3. Time to obtain valid data after exiting power-down mode

2.3 Communication interface characteristics

2.3.1 SPI - serial peripheral interface

Subject to general operating conditions for Vdd and Top.

Table 5. SPI slave timing values

Symbol	Parameter	Value ⁽¹⁾		Unit
		Min	Max	
$t_{c(SPC)}$	SPI clock cycle	100		ns
$f_{c(SPC)}$	SPI clock frequency		10	MHz
$t_{su(CS)}$	CS setup time	6		ns
$t_{h(CS)}$	CS hold time	8		
$t_{su(SI)}$	SDI input setup time	5		
$t_{h(SI)}$	SDI input hold time	15		
$t_{v(SO)}$	SDO valid output time		50	
$t_{h(SO)}$	SDO output hold time	9		
$t_{dis(SO)}$	SDO output disable time		50	

Figure 3. SPI slave timing diagram ⁽²⁾

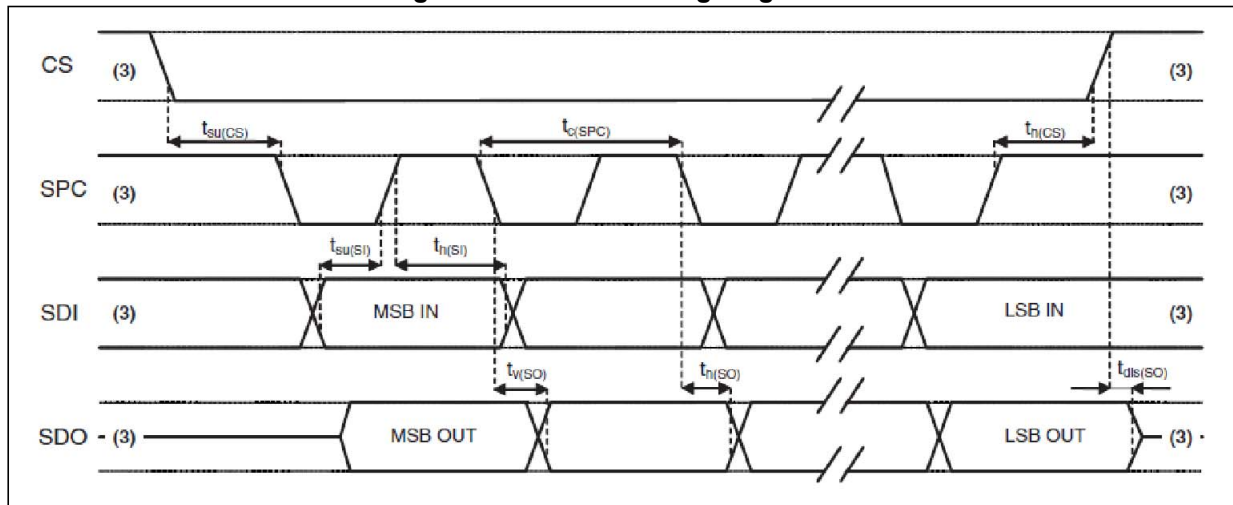

1. Values are guaranteed at 10 MHz clock frequency for SPI with both 4 and 3 wires, based on characterization results, not tested in production.
2. Measurement points are done at $0.2 \cdot V_{dd_IO}$ and $0.8 \cdot V_{dd_IO}$, for both input and output ports.
3. When no communication is ongoing, data on CS, SPC, SDI and SDO are driven by internal pull-up resistors.

2.3.2 I²C - inter-IC control interface

Subject to general operating conditions for V_{dd} and top.

Table 6. I²C slave timing values

Symbol	Parameter	I ² C standard mode ⁽¹⁾		I ² C fast mode ⁽¹⁾		Unit
		Min	Max	Min	Max	
f _(SCL)	SCL clock frequency	0	100	0	400	KHz
t _{w(SCLL)}	SCL clock low time	4.7		1.3		μs
t _{w(SCLH)}	SCL clock high time	4.0		0.6		
t _{su(SDA)}	SDA setup time	250		100		ns
t _{h(SDA)}	SDA data hold time	0.01	3.45	0.01	0.9	μs
t _{h(ST)}	START condition hold time	4		0.6		μs
t _{su(SR)}	Repeated START condition setup time	4.7		0.6		
t _{su(SP)}	STOP condition setup time	4		0.6		
t _{w(SP:SR)}	Bus free time between STOP and START condition	4.7		1.3		

1. Data based on standard I²C protocol requirement, not tested in production

Figure 4. I²C slave timing diagram^(a)

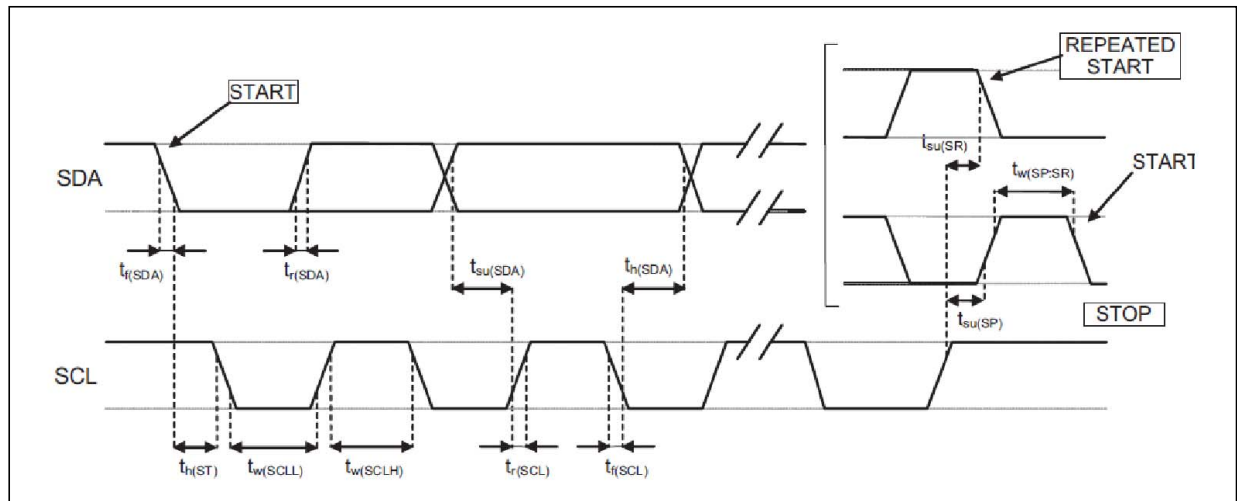

a. Measurement points are done at 0.2·V_{dd_IO} and 0.8·V_{dd_IO}, for both ports.

2.4 Absolute maximum ratings

Stresses above those listed as “absolute maximum ratings” may cause permanent damage to the device. This is a stress rating only and functional operation of the device under these conditions is not implied. Exposure to maximum rating conditions for extended periods may affect device reliability.

Table 7. Absolute maximum ratings

Symbol	Ratings	Maximum value	Unit
V _{dd}	Supply voltage	-0.3 to 4	V
V _{dd_IO}	I/O pins supply voltage	-0.3 to V _{dd} +0.1	V
V _{in}	Input voltage on any control pin (CS, SCL/SPC, SDA/SDI/SDO, SDO/SA0)	-0.3 to V _{dd_IO} +0.3	V
A _{POW}	Acceleration (any axis, powered, V _{dd} = 2.5 V)	3000 g for 0.5 ms	
		10000 g for 0.1 ms	
A _{UNP}	Acceleration (any axis, unpowered)	3000 g for 0.5 ms	
		10000 g for 0.1 ms	
T _{OP}	Operating temperature range	-40 to +105	°C
T _{STG}	Storage temperature range	-40 to +125	°C
ESD	Electrostatic discharge protection	2 (HBM)	kV
		500 (CDM)	V
		200 (MM)	V

Note: Supply voltage on any pin should never exceed 4.0 V



This device is sensitive to mechanical shock, improper handling can cause permanent damages to the part.



This device is sensitive to electrostatic discharge (ESD), improper handling can cause permanent damages to the part.

2.5 Terminology

2.5.1 Sensitivity

Sensitivity describes the gain of the sensor and can be determined, for example, by applying 1 g acceleration to it. As the sensor can measure DC accelerations this can be done easily by pointing the axis of interest towards the center of the Earth, noting the output value, rotating the sensor by 180 degrees (pointing to the sky) and noting the output value again. By doing so, ± 1 g acceleration is applied to the sensor. Subtracting the larger output value from the smaller one, and dividing the result by 2, leads to the actual sensitivity of the sensor. This value changes very little over temperature and time. The sensitivity tolerance describes the range of sensitivities of a large population of sensors.

2.5.2 Zero-g level

Zero-g level offset (TyOff) describes the deviation of an actual output signal from the ideal output signal if no acceleration is present. A sensor in a steady state on a horizontal surface will measure 0 g for the X-axis and 0 g for the Y-axis whereas the Z-axis will measure 1 g. The output is ideally in the middle of the dynamic range of the sensor (content of OUT registers 00h, data expressed as 2's complement number). A deviation from the ideal value in this case is called Zero-g offset. Offset is to some extent a result of stress to MEMS sensor and therefore the offset can slightly change after mounting the sensor onto a printed circuit board or exposing it to extensive mechanical stress. Offset changes little over temperature, see "Zero-g level change vs. temperature".

2.5.3 Self-test

Self-test allows checking the sensor functionality without moving it. The self-test function is off when the self-test bit (ST) of CTRL_REG4 (control register 4) is programmed to '0'. When the self-test bit of CTRL_REG4 is programmed to '1', an actuation force is applied to the sensor, simulating a definite input acceleration. In this case the sensor outputs will exhibit a change in their DC levels which are related to the selected full scale through the device sensitivity. When self-test is activated, the device output level is given by the algebraic sum of the signals produced by the acceleration acting on the sensor and by the electrostatic test-force. If the output signals change within the amplitude specified inside [Table 3](#), then the sensor is working properly and the parameters of the interface chip are within the defined specifications.

2.5.4 Sleep-to-wake

The "sleep-to-wakeup" function, in conjunction with low-power mode, allows to further reduce the system power consumption and develop new smart applications. AIS3624DQ may be set in a low-power operating mode, characterized by lower data rate updates. In this way the device, even if sleeping, continues to sense acceleration and generate interrupt requests.

When the "sleep-to-wake" function is activated, AIS3624DQ is able to automatically wake up as soon as the interrupt event has been detected, increasing the output data rate and bandwidth.

With this feature the system may be efficiently switched from low-power mode to full-performance depending on user-selectable positioning and acceleration events, thus ensuring power saving and flexibility.

3 Functionality

The AIS3624DQ is a nano, low-power, digital output 3-axis linear accelerometer available or housed in a QFN package. The complete device includes a sensing element and an IC interface. The device comprises a sensing element and an IC interface which communicates through an I²C or SPI serial interface from the sensing element to the application.

3.1 Sensing element

A proprietary process is used to create a surface micromachined accelerometer. The technology allows processing suspended silicon structures which are attached to the substrate in a few points called anchors and are free to move in the direction of the sensed acceleration. In order to be compatible with traditional packaging techniques, a cap is placed on top of the sensing element to avoid blocking the moving parts during the molding phase of the plastic encapsulation.

When an acceleration is applied to the sensor, the proof mass displaces from its nominal position, causing an imbalance in the capacitive half-bridge. This imbalance is measured using charge integration in response to a voltage pulse applied to the capacitor.

At steady state the nominal value of the capacitors are few pF and when an acceleration is applied the maximum variation of the capacitive load is in the fF range.

3.2 IC interface

The complete measurement chain is composed of a low-noise capacitive amplifier which converts the capacitive unbalancing of the MEMS sensor into an analog voltage using an analog-to-digital converter.

The acceleration data may be accessed through an I²C/SPI interface thus making the device particularly suitable for direct interfacing with a microcontroller.

The AIS3624DQ features a Data-Ready signal (RDY) which indicates when a new set of measured acceleration data is available, thus simplifying data synchronization in the digital system that uses the device.

The AIS3624DQ may also be configured to generate an inertial wakeup and free-fall interrupt signal according to a programmed acceleration event along the enabled axes. Both free-fall and wakeup can be available simultaneously on two different pins.

3.3 Factory calibration

The IC interface is factory calibrated for sensitivity (S₀) and Zero-g level (T_{yOff}).

The trimming values are stored inside the device in a non-volatile memory. Any time the device is turned on, the trimming parameters are downloaded into the registers to be employed during active operation which allows the device to be used without further calibration.

4 Application hints

Figure 5. AIS3624DQ electrical connections

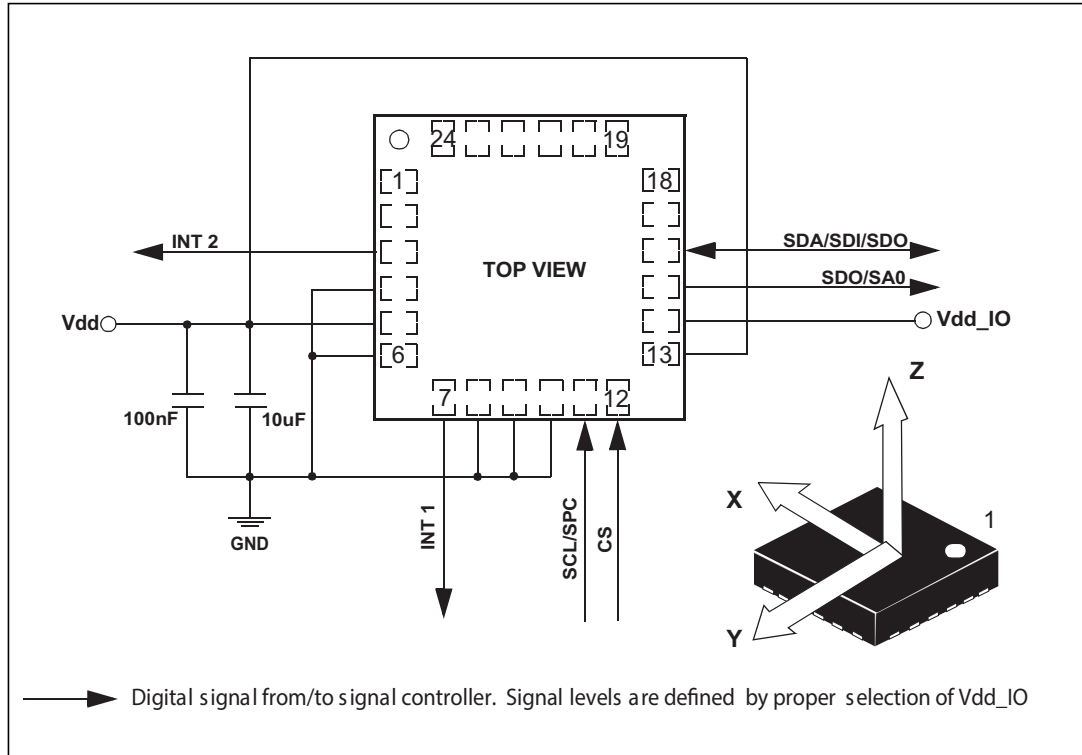

The device core is supplied through Vdd line while the I/O pads are supplied through the Vdd_IO line. Power supply decoupling capacitors (100 nF ceramic, 10 μ F aluminum) should be placed as near as possible to the pin 14 of the device (common design practice).

All the voltage and ground supplies must be present at the same time to have proper behavior of the IC (refer to [Figure 5](#)). It is possible to remove Vdd while maintaining Vdd_IO without blocking the communication bus, in this condition the measurement chain is powered off.

The functionality of the device and the measured acceleration data is selectable and accessible through the I²C or SPI interfaces. When using the I²C, CS must be tied high.

The functions, the threshold and the timing of the two interrupt pins (INT 1 and INT 2) can be completely programmed by the user through the I²C/SPI interface.

4.1 Soldering information

The QFN package is compliant with the ECOPACK[®], RoHS and “Green” standard. It is qualified for soldering heat resistance according to JEDEC J-STD-020C.

Leave “Pin 1 Indicator” unconnected during soldering.

Land pattern and soldering recommendations are available at www.st.com.

5 Digital interfaces

The registers embedded inside the AIS3624DQ may be accessed through both the I²C and SPI serial interfaces. The latter may be SW configured to operate either in 3-wire or 4-wire interface mode.

The serial interfaces are mapped onto the same pads. To select/exploit the I²C interface, the CS line must be tied high (i.e. connected to Vdd_IO).

Table 8. Serial interface pin description

Pin name	Pin description
CS	SPI enable I ² C/SPI mode selection (1: I ² C mode; 0: SPI enabled)
SCL	I ² C serial clock (SCL)
SPC	SPI serial port clock (SPC)
SDA	I ² C serial data (SDA)
SDI	SPI serial data input (SDI)
SDO	3-wire interface serial data output (SDO)
SA0	I ² C less significant bit of the device address (SA0)
SDO	SPI serial data output (SDO)

5.1 I²C serial interface

The AIS3624DQ I²C is a bus slave. The I²C is employed to write data into registers whose content can also be read back.

The relevant I²C terminology is given in the table below.

Table 9. I²C terminology

Term	Description
Transmitter	The device which sends data to the bus
Receiver	The device which receives data from the bus
Master	The device which initiates a transfer, generates clock signals and terminates a transfer
Slave	The device addressed by the master

There are two signals associated with the I²C bus: the serial clock line (SCL) and the Serial Data line (SDA). The latter is a bidirectional line used for sending and receiving the data to/from the interface. Both the lines are connected to Vdd_IO through a pull-up resistor embedded inside the AIS3624DQ. When the bus is free, both the lines are high.

The I²C interface is compliant with fast mode (400 kHz) I²C standards as well as with the normal mode.

5.1.1 I²C operation

The transaction on the bus is started through a START (ST) signal. A START condition is defined as a HIGH-to-LOW transition on the data line while the SCL line is held HIGH. After this has been transmitted by the master, the bus is considered busy. The next byte of data transmitted after the start condition contains the address of the slave in the first 7 bits and the eighth bit tells whether the master is receiving data from the slave or transmitting data to the slave. When an address is sent, each device in the system compares the first seven bits after a start condition with its address. If they match, the device considers itself addressed by the master.

The Slave Address (SAD) associated to the AIS3624DQ is 001100xb. The **SDO/SA0** pad can be used to modify the less significant bit of the device address. If the SA0 pad is connected to the voltage supply, LSb is '1' (address 0011001b), else if the SA0 pad is connected to ground, the LSb value is '0' (address 0011000b). This solution permits to connect and address two different accelerometers to the same I²C lines.

Data transfer with acknowledge is mandatory. The transmitter must release the SDA line during the acknowledge pulse. The receiver must then pull the data line LOW so that it remains stable low during the HIGH period of the acknowledge clock pulse. A receiver which has been addressed is obliged to generate an acknowledge after each byte of data received.

The I²C embedded inside the AIS3624DQ behaves like a slave device and the following protocol must be adhered to. After the start condition (ST) a slave address is sent, once a slave acknowledge (SAK) has been returned, an 8-bit sub-address (SUB) is transmitted: the 7 LSb represent the actual register address while the MSB enables address auto increment. If the MSb of the SUB field is '1', the SUB (register address) is automatically increased to allow multiple data read/write.

The slave address is completed with a Read/Write bit. If the bit was '1' (Read), a repeated START (SR) condition must be issued after the two sub-address bytes; if the bit is '0' (Write) the master will transmit to the slave with direction unchanged. [Table 10](#) explains how the SAD+Read/Write bit pattern is composed, listing all the possible configurations.

Table 10. SAD+Read/Write patterns

Command	SAD[6:1]	SAD[0] = SA0	R/W	SAD+R/W
Read	001100	0	1	00110001 (31h)
Write	001100	0	0	00110000 (30h)
Read	001100	1	1	00110011 (33h)
Write	001100	1	0	00110010 (32h)

Table 11. Transfer when master is writing one byte to slave

Master	ST	SAD + W		SUB		DATA		SP
Slave			SAK		SAK		SAK	

Table 12. Transfer when master is writing multiple bytes to slave:

Master	ST	SAD + W		SUB		DATA		DATA		SP
Slave			SAK		SAK		SAK		SAK	

Table 13. Transfer when master is receiving (reading) one byte of data from slave:

Master	ST	SAD + W		SUB		SR	SAD + R			NMAK	SP
Slave			SAK		SAK			SAK	DATA		

Table 14. Transfer when master is receiving (reading) multiple bytes of data from slave

Master	ST	SAD+W		SUB		SR	SAD+R			MAK		MAK		NMAK	SP
Slave			SAK		SAK			SAK	DATA		DAT A		DAT A		

Data are transmitted in byte format (DATA). Each data transfer contains 8 bits. The number of bytes transferred per transfer is unlimited. Data is transferred with the Most Significant bit (MSb) first. If a receiver can't receive another complete byte of data until it has performed some other function, it can hold the clock line, SCL LOW to force the transmitter into a wait state. Data transfer only continues when the receiver is ready for another byte and releases the data line. If a slave receiver doesn't acknowledge the slave address (i.e. it is not able to receive because it is performing some real time function) the data line must be left HIGH by the slave. The master can then abort the transfer. A LOW-to-HIGH transition on the SDA line while the SCL line is HIGH is defined as a STOP condition. Each data transfer must be terminated by the generation of a STOP (SP) condition.

In order to read multiple bytes, it is necessary to assert the most significant bit of the sub-address field. In other words, SUB(7) must be equal to 1 while SUB(6-0) represents the address of first register to be read.

In the presented communication format MAK is Master acknowledge and NMAK is No Master Acknowledge.

5.2 SPI bus interface

The AIS3624DQ SPI is a bus slave. The SPI allows writing to and reading from the registers of the device.

The serial interface interacts with the outside world with 4 wires: **CS**, **SPC**, **SDI** and **SDO**.

Figure 6. Read and write protocol

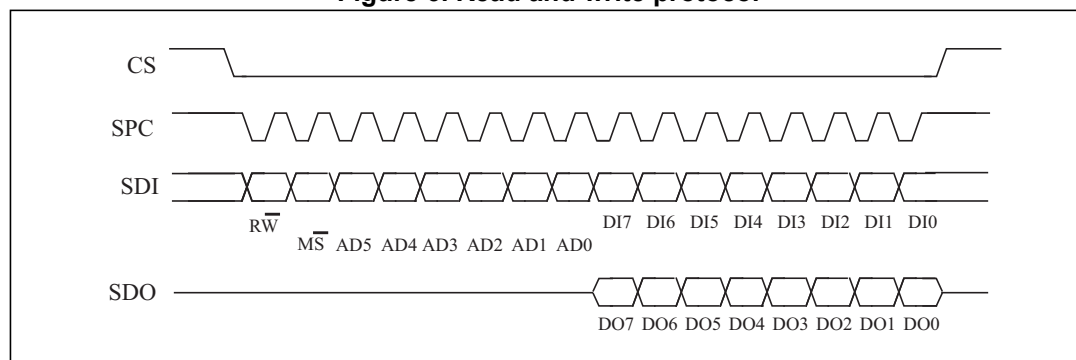

CS is the serial port enable and it is controlled by the SPI master. It goes low at the start of the transmission and goes back high at the end. **SPC** is the serial port clock and it is controlled by the SPI master. It is stopped high when **CS** is high (no transmission). **SDI** and

SDO are respectively the serial port data input and output. Those lines are driven at the falling edge of **SPC** and should be captured at the rising edge of **SPC**.

Both the read register and write register commands are completed in 16 clock pulses or in multiple of 8 in the case of multiple read/write bytes. Bit duration is the time between two falling edges of **SPC**. The first bit (bit 0) starts at the first falling edge of **SPC** after the falling edge of **CS** while the last bit (bit 15, bit 23, ...) starts at the last falling edge of **SPC** just before the rising edge of **CS**.

bit 0: \overline{RW} bit. When 0, the data $DI(7:0)$ is written into the device. When 1, the data $DO(7:0)$ from the device is read. In latter case, the chip will drive **SDO** at the start of bit 8.

bit 1: \overline{MS} bit. When 0, the address will remain unchanged in multiple read/write commands. When 1, the address is auto incremented in multiple read/write commands.

bit 2-7: address $AD(5:0)$. This is the address field of the indexed register.

bit 8-15: data $DI(7:0)$ (write mode). This is the data that is written into the device (MSb first).

bit 8-15: data $DO(7:0)$ (read mode). This is the data that is read from the device (MSb first).

In multiple read/write commands further blocks of 8 clock periods will be added. When the \overline{MS} bit is '0', the address used to read/write data remains the same for every block. When the \overline{MS} bit is '1', the address used to read/write data is increased at every block.

The function and the behavior of **SDI** and **SDO** remain unchanged.

5.2.1 SPI read

Figure 7. SPI read protocol

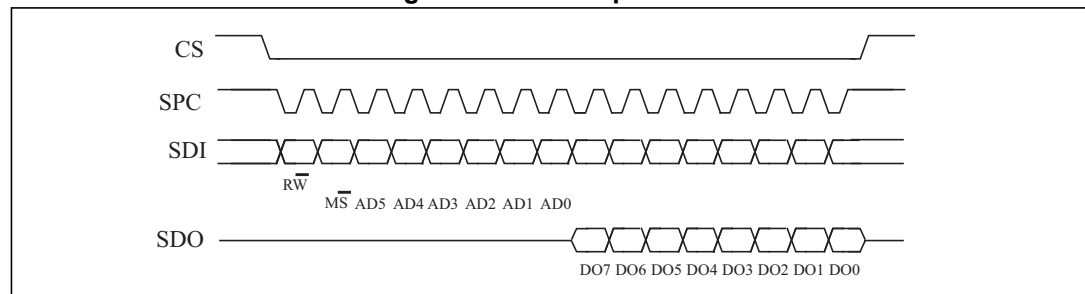

The SPI Read command is performed with 16 clock pulses. Multiple byte read command is performed adding blocks of 8 clock pulses at the previous one.

bit 0: READ bit. The value is 1.

bit 1: \overline{MS} bit. When 0, does not increment the address; when 1, increments the address in multiple reads.

bit 2-7: address $AD(5:0)$. This is the address field of the indexed register.

bit 8-15: data $DO(7:0)$ (read mode). This is the data that will be read from the device (MSb first).

bit 16-...: data $DO(...-8)$. Further data in multiple byte reads.

Figure 8. Multiple byte SPI read protocol (2-byte example)

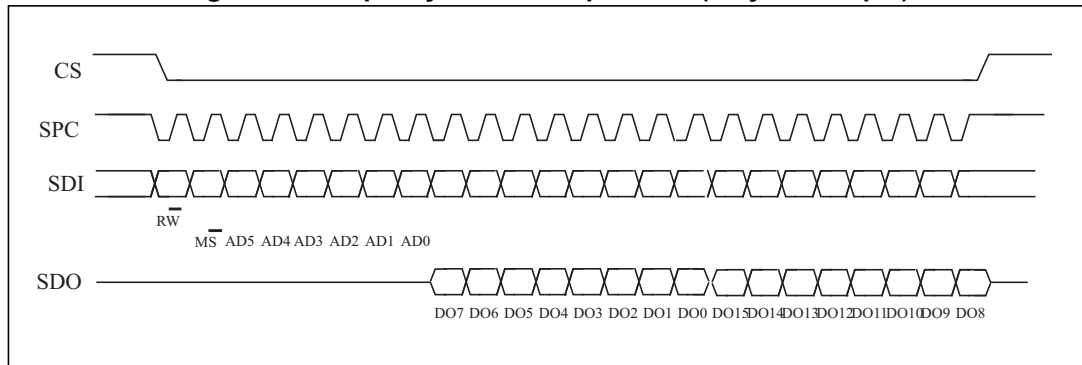

5.2.2 SPI write

Figure 9. SPI write protocol

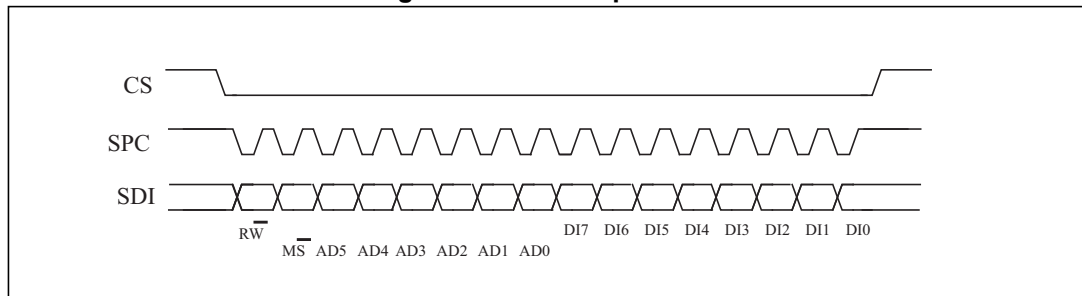

The SPI write command is performed with 16 clock pulses. A multiple byte write command is performed by adding blocks of 8 clock pulses to the previous one.

bit 0: WRITE bit. The value is 0.

bit 1: \overline{MS} bit. When 0, does not increment the address; when 1, increments the address in multiple writes.

bit 2 -7: address AD(5:0). This is the address field of the indexed register.

bit 8-15: data DI(7:0) (write mode). This is the data that is written inside the device (MSb first).

bit 16-... : data DI(...-8). Further data in multiple byte writes.

Figure 10. Multiple byte SPI write protocol (2-byte example)

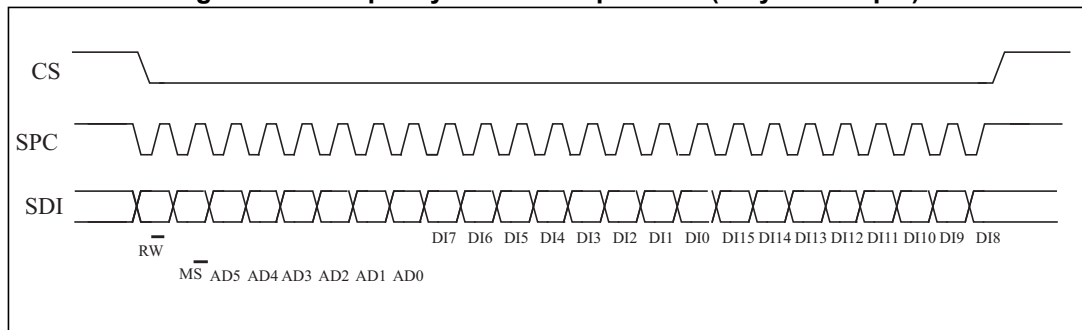

5.2.3 SPI read in 3-wire mode

3-wire mode is entered by setting bit SIM to '1' (SPI serial interface mode selection) in CTRL_REG4.

Figure 11. SPI read protocol in 3-wire mode

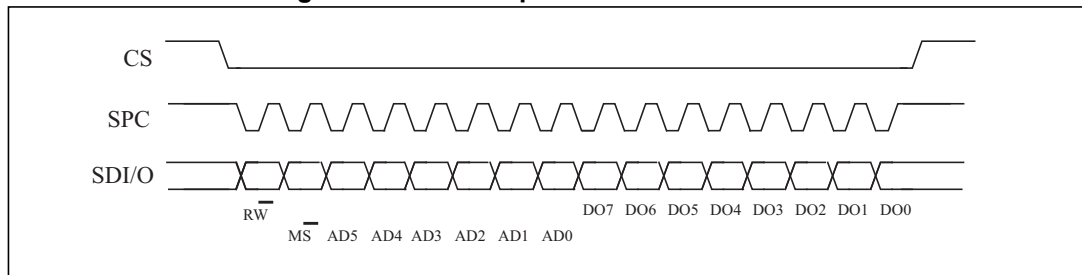

The SPI read command is performed with 16 clock pulses:

bit 0: READ bit. The value is 1.

bit 1: \overline{MS} bit. When 0, does not increment the address; when 1, increments the address in multiple reads.

bit 2-7: address AD(5:0). This is the address field of the indexed register.

bit 8-15: data DO(7:0) (read mode). This is the data that is read from the device (MSb first).

A multiple read command is also available in 3-wire mode.

6 Register mapping

The table given below provides a list of the 8-bit registers embedded in the device and the corresponding addresses.

Table 15. Register address map

Name	Type	Register address		Default	Comment
		Hex	Binary		
Reserved (do not modify)		00 - 0E			Reserved
WHO_AM_I	r	0F	000 1111	00110010	Dummy register
Reserved (do not modify)		10 - 1F			Reserved
CTRL_REG1	rw	20	010 0000	00000111	
CTRL_REG2	rw	21	010 0001	00000000	
CTRL_REG3	rw	22	010 0010	00000000	
CTRL_REG4	rw	23	010 0011	00000000	
CTRL_REG5	rw	24	010 0100	00000000	
HP_FILTER_RESET	r	25	010 0101		Dummy register
REFERENCE	rw	26	010 0110	00000000	
STATUS_REG	r	27	010 0111	00000000	
OUT_X_L	r	28	010 1000	output	
OUT_X_H	r	29	010 1001	output	
OUT_Y_L	r	2A	010 1010	output	
OUT_Y_H	r	2B	010 1011	output	
OUT_Z_L	r	2C	010 1100	output	
OUT_Z_H	r	2D	010 1101	output	
Reserved (do not modify)		2E - 2F			Reserved
INT1_CFG	rw	30	011 0000	00000000	
INT1_SOURCE	r	31	011 0001	00000000	
INT1_THS	rw	32	011 0010	00000000	
INT1_DURATION	rw	33	011 0011	00000000	
INT2_CFG	rw	34	011 0100	00000000	
INT2_SOURCE	r	35	011 0101	00000000	
INT2_THS	rw	36	011 0110	00000000	
INT2_DURATION	rw	37	011 0111	00000000	
Reserved (do not modify)		38 - 3F			Reserved

Registers marked as *Reserved* must not be changed. Writing to those registers may cause permanent damage to the device. The content of the registers that are loaded at boot should not be changed. They contain the factory calibration values. Their content is automatically restored when the device is powered up.

7 Register description

The device contains a set of registers which are used to control its behavior and to retrieve acceleration data. The register address, made of 7 bits, is used to identify them and to write the data through the serial interface.

7.1 WHO_AM_I (0Fh)

Table 16. WHO_AM_I register

0	0	1	1	0	0	1	0
---	---	---	---	---	---	---	---

Device identification register.

This register contains the device identifier that for AIS3624DQ is set to 32h.

7.2 CTRL_REG1 (20h)

Table 17. CTRL_REG1 register

PM2	PM1	PM0	DR1	DR0	Zen	Yen	Xen
-----	-----	-----	-----	-----	-----	-----	-----

Table 18. CTRL_REG1 description

PM2 - PM0	Power mode selection. Default value: 000 (000: Power-down; Others: refer to Table 19)
DR1 - DR0	Data rate selection. Default value: 00 (00: 50 Hz; Others: refer to Table 20)
Zen	Z-axis enable. Default value: 1 (0: Z-axis disabled; 1: Z-axis enabled)
Yen	Y-axis enable. Default value: 1 (0: Y-axis disabled; 1: Y-axis enabled)
Xen	X axis enable. Default value: 1 (0: X-axis disabled; 1: X-axis enabled)

The **PM** bits allow selecting between power-down and two operating active modes. The device is in power-down mode when the PD bits are set to “000” (default value after boot). [Table 19](#) shows all the possible power mode configurations and respective output data rates. Output data in the low-power modes are computed with low-pass filter cutoff frequency defined by the DR1 and DR0 bits.

The **DR** bits, in the normal-mode operation, select the data rate at which acceleration samples are produced. In low-power mode they define the output data resolution. [Table 20](#) shows all the possible configurations for the DR1 and DR0 bits.

Table 19. Power mode and low-power output data rate configurations

PM2	PM1	PM0	Power mode selection	Output data rate [Hz] ODR _{LP}
0	0	0	Power-down	--
0	0	1	Normal mode	ODR
0	1	0	Low-power	0.5
0	1	1	Low-power	1
1	0	0	Low-power	2
1	0	1	Low-power	5
1	1	0	Low-power	10

Table 20. Normal-mode output data rate configurations and low-pass cutoff frequencies

DR1	DR0	Output Data Rate [Hz] ODR	Low-pass filter cutoff frequency [Hz]
0	0	50	37
0	1	100	74
1	0	400	292
1	1	1000	780

7.3 CTRL_REG2 (21h)

Table 21. CTRL_REG2 register

BOOT	HPM1	HPM0	FDS	HPen2	HPen1	HPCF1	HPCF0
------	------	------	-----	-------	-------	-------	-------

Table 22. CTRL_REG2 description

BOOT	Reboot memory content. Default value: 0 (0: normal mode; 1: reboot memory content)
HPM1, HPM0	High-pass filter mode selection. Default value: 00 (00: normal mode; Others: refer to Table 23)
FDS	Filtered data selection. Default value: 0 (0: internal filter bypassed; 1: data from internal filter sent to output register)
HPen2	High-pass filter enabled for interrupt 2 source. Default value: 0 (0: filter bypassed; 1: filter enabled)
HPen1	High-pass filter enabled for interrupt 1 source. Default value: 0 (0: filter bypassed; 1: filter enabled)
HPCF1, HPCF0	High-pass filter cutoff frequency configuration. Default value: 00 (00: HPC=8; 01: HPC=16; 10: HPC=32; 11: HPC=64)

The **BOOT** bit is used to refresh the content of internal registers stored in the flash memory block. At the device power-up the content of the flash memory block is transferred to the internal registers related to the trimming functions to allow correct behavior of the device itself. If for any reason the content of trimming registers is changed, it is sufficient to use this bit to restore the correct values. When the BOOT bit is set to '1', the content of internal flash is copied inside the corresponding internal registers and it is used to calibrate the device. These values are factory trimmed and they are different for every accelerometer. They allow correct behavior of the device and normally they have not to be changed. At the end of the boot process the BOOT bit is set again to '0'.

Table 23. High-pass filter mode configuration

HPM1	HPM0	High-pass filter mode
0	0	Normal mode (reset by reading HP_RESET_FILTER)
0	1	Reference signal for filtering
1	0	Normal mode (reset by reading HP_RESET_FILTER)

HPCF[1:0]. These bits are used to configure the high-pass filter cutoff frequency f_t which is given by:

$$f_t = \ln\left(1 - \frac{1}{\text{HPC}}\right) \cdot \frac{f_s}{2\pi}$$

The equation can be simplified to the following approximation:

$$f_t = \frac{f_s}{6 \cdot \text{HPC}}$$

Table 24. High-pass filter cutoff frequency configuration

HPcoeff2,1	f_t [Hz] Data rate = 50 Hz	f_t [Hz] Data rate = 100 Hz	f_t [Hz] Data rate = 400 Hz	f_t [Hz] Data rate = 1000 Hz
00	1	2	8	20
01	0.5	1	4	10
10	0.25	0.5	2	5
11	0.125	0.25	1	2.5

7.4 CTRL_REG3 [interrupt CTRL register] (22h)

Table 25. CTRL_REG3 register

IHL	PP_OD	LIR2	I2_CFG1	I2_CFG0	LIR1	I1_CFG1	I1_CFG0
-----	-------	------	---------	---------	------	---------	---------

Table 26. CTRL_REG3 description

IHL	Interrupt active high, low. Default value: 0 (0: active high; 1: active low)
PP_OD	Push-pull/Open-drain selection on interrupt pads. Default value 0. (0: push-pull; 1: open-drain)
LIR2	Latch interrupt request on INT2_SRC register, with INT2_SRC register cleared by reading INT2_SRC itself. Default value: 0. (0: interrupt request not latched; 1: interrupt request latched)
I2_CFG1, I2_CFG0	Data signal on INT 2 pad control bits. Default value: 00. (see table below)
LIR1	Latch interrupt request in the INT1_SRC register, with INT1_SRC register cleared by reading INT1_SRC register. Default value: 0. (0: interrupt request not latched; 1: interrupt request latched)
I1_CFG1, I1_CFG0	Data signal on INT 1 pad control bits. Default value: 00. (see table below)

Table 27. Data signal on INT 1 and INT 2 pads

I1(2)_CFG1	I1(2)_CFG0	INT 1(2) Pad
0	0	Interrupt 1 (2) source
0	1	Interrupt 1 source OR interrupt 2 source
1	0	Data ready
1	1	Boot running

7.5 CTRL_REG4 (23h)

Table 28. CTRL_REG4 register

BDU	BLE	FS1	FS0	STsign	0	ST	SIM
-----	-----	-----	-----	--------	---	----	-----

Table 29. CTRL_REG4 description

BDU	Block data update. Default value: 0 (0: continuous update; 1: output registers not updated between MSB and LSB reading)
BLE	Big/little endian data selection. Default value 0. (0: data LSB @ lower address; 1: data MSB @ lower address)
FS1, FS0	Full-scale selection. Default value: 00. (00: $\pm 6 g$; 01: $\pm 12 g$; 11: $\pm 24 g$)
STsign	Self-test sign. Default value: 00. (0: self-test plus; 1 self-test minus)
ST	Self-test enable. Default value: 0. (0: self-test disabled; 1: self-test enabled)
SIM	SPI serial interface mode selection. Default value: 0. (0: 4-wire interface; 1: 3-wire interface)

The BDU bit is used to inhibit the update of the output registers until both upper and lower register parts are read. In default mode (BDU=0), the output register values are updated continuously. When the BDU is activated (BDU =1), the content of the output registers is not updated until both MSB and LSB are read which avoids reading values related to different sample times.

7.6 CTRL_REG5 (24h)

Table 30. CTRL_REG5 register

0	0	0	0	0	0	TurnOn1	TurnOn0
---	---	---	---	---	---	---------	---------

Table 31. CTRL_REG5 description

TurnOn1, TurnOn0	Turn-on mode selection for sleep-to-wake function. Default value: 00.
---------------------	---

The **TurnOn** bits are used for turning on the **sleep-to-wake** function.

Table 32. Sleep-to-wake configuration

TurnOn1	TurnOn0	Sleep-to-wake status
0	0	Sleep-to-wake function is disabled
1	1	Turned on: The device is in low power mode (ODR is defined in CTRL_REG1)

Setting the TurnOn[1:0] bits to 11, the “sleep-to-wake” function is enabled. When an interrupt event occurs, the device returns to normal mode, increasing the ODR to the value defined in CTRL_REG1. Although the device is in normal mode, CTRL_REG1 content is not automatically changed to “normal mode” configuration.

7.7 HP_FILTER_RESET (25h)

Dummy register. Reading from this address zeroes instantaneously the content of the internal high-pass filter. If the high-pass filter is enabled, all three axes are instantaneously set to 0 g. This allows nullifying the settling time of the high-pass filter.

7.8 REFERENCE (26h)

Table 33. REFERENCE register

Ref7	Ref6	Ref5	Ref4	Ref3	Ref2	Ref1	Ref0
------	------	------	------	------	------	------	------

Table 34. REFERENCE description

Ref7 - Ref0	Reference value for high-pass filter. Default value: 00h.
-------------	---

This register sets the acceleration value taken as a reference for the high-pass filter output. When the filter is turned on (at least one of the FDS, HPen2, or HPen1 bits is equal to '1'), and HPM bits are set to "01", the filter output is generated, taking this value as a reference.

7.9 STATUS_REG (27h)

Table 35. STATUS_REG register

ZYXOR	ZOR	YOR	XOR	ZYXDA	ZDA	YDA	XDA
-------	-----	-----	-----	-------	-----	-----	-----

Table 36. STATUS_REG description

ZYXOR	X-, Y- and Z-axis data overrun. Default value: 0 (0: no overrun has occurred; 1: new data has overwritten the previous data before it was read)
ZOR	Z-axis data overrun. Default value: 0 (0: no overrun has occurred; 1: new data for the Z-axis has overwritten the previous data)
YOR	Y-axis data overrun. Default value: 0 (0: no overrun has occurred; 1: a new data for the Y-axis has overwritten the previous data)
XOR	X-axis data overrun. Default value: 0 (0: no overrun has occurred; 1: new data for the X-axis has overwritten the previous data)
ZYXDA	X-, Y- and Z-axis new data available. Default value: 0 (0: a new set of data is not yet available; 1: a new set of data is available)
ZDA	Z-axis new data available. Default value: 0 (0: new data for the Z-axis is not yet available; 1: new data for the Z-axis is available)
YDA	Y-axis new data available. Default value: 0 (0: new data for the Y-axis is not yet available; 1: new data for the Y-axis is available)
XDA	X-axis new data available. Default value: 0 (0: new data for the X-axis is not yet available; 1: new data for the X-axis is available)

7.10 OUT_X_L (28h), OUT_X_H (29)

X-axis acceleration data. The value is expressed as two's complement.

7.11 OUT_Y_L (2Ah), OUT_Y_H (2Bh)

Y-axis acceleration data. The value is expressed as two's complement.

7.12 OUT_Z_L (2Ch), OUT_Z_H (2Dh)

Z-axis acceleration data. The value is expressed as two's complement.

7.13 INT1_CFG (30h)**Table 37. INT1_CFG register**

AOI	6D	ZHIE	ZLIE	YHIE	YLIE	XHIE	XLIE
-----	----	------	------	------	------	------	------

Table 38. INT1_CFG description

AOI	AND/OR combination of Interrupt events. Default value: 0 (See Table 39)
6D	6-direction detection function enable. Default value: 0 (See Table 39)
ZHIE	Enable interrupt generation on Z high event. Default value: 0 (0: disable interrupt request; 1: enable interrupt request on measured accel. value higher than preset threshold)
ZLIE	Enable interrupt generation on Z low event. Default value: 0 (0: disable interrupt request; 1: enable interrupt request on measured accel. value lower than preset threshold)
YHIE	Enable interrupt generation on Y high event. Default value: 0 (0: disable interrupt request; 1: enable interrupt request on measured accel. value higher than preset threshold)
YLIE	Enable interrupt generation on Y low event. Default value: 0 (0: disable interrupt request; 1: enable interrupt request on measured accel. value lower than preset threshold)
XHIE	Enable interrupt generation on X high event. Default value: 0 (0: disable interrupt request; 1: enable interrupt request on measured accel. value higher than preset threshold)
XLIE	Enable interrupt generation on X low event. Default value: 0 (0: disable interrupt request; 1: enable interrupt request on measured accel. value lower than preset threshold)

Configuration register for Interrupt 1 source.

Table 39. Interrupt 1 source configurations

AOI	6D	Interrupt mode
0	0	OR combination of interrupt events
0	1	6-direction movement recognition
1	0	AND combination of interrupt events
1	1	6-direction position recognition

7.14 INT1_SRC (31h)

Table 40. INT1_SRC register

0	IA	ZH	ZL	YH	YL	XH	XL
---	----	----	----	----	----	----	----

Table 41. INT1_SRC description

IA	Interrupt active. Default value: 0 (0: no interrupt has been generated; 1: one or more interrupts have been generated)
ZH	Z high. Default value: 0 (0: no interrupt, 1: Z high event has occurred)
ZL	Z low. Default value: 0 (0: no interrupt; 1: Z low event has occurred)
YH	Y high. Default value: 0 (0: no interrupt, 1: Y high event has occurred)
YL	Y low. Default value: 0 (0: no interrupt, 1: Y low event has occurred)
XH	X high. Default value: 0 (0: no interrupt, 1: X high event has occurred)
XL	X low. Default value: 0 (0: no interrupt, 1: X low event has occurred)

Interrupt 1 source register. Read-only register.

Reading at this address clears the INT1_SRC IA bit (and the interrupt signal on the INT 1 pin) and allows the refresh of data in the INT1_SRC register if the latched option was chosen.

7.15 INT1_THS (32h)

Table 42. INT1_THS register

0	THS6	THS5	THS4	THS3	THS2	THS1	THS0
---	------	------	------	------	------	------	------

Table 43. INT1_THS description

THS6 - THS0	Interrupt 1 threshold. Default value: 000 0000
-------------	--

7.16 INT1_DURATION (33h)

Table 44. INT1_DURATION register

0	D6	D5	D4	D3	D2	D1	D0
---	----	----	----	----	----	----	----

Table 45. INT2_DURATION description

D6 - D0	Duration value. Default value: 000 0000
---------	---

The **D6 - D0** bits set the minimum duration of the Interrupt 2 event to be recognized. Duration steps and maximum values depend on the ODR chosen.

7.17 INT2_CFG (34h)

Table 46. INT2_CFG register

AOI	6D	ZHIE	ZLIE	YHIE	YLIE	XHIE	XLIE
-----	----	------	------	------	------	------	------

Table 47. INT2_CFG description

AOI	AND/OR combination of interrupt events. Default value: 0 (See Table 48)
6D	6-direction detection function enable. Default value: 0 (See Table 48)
ZHIE	Enable interrupt generation on Z high event. Default value: 0 (0: disable interrupt request; 1: enable interrupt request on measured accel. value higher than preset threshold)
ZLIE	Enable interrupt generation on Z low event. Default value: 0 (0: disable interrupt request; 1: enable interrupt request on measured accel. value lower than preset threshold)
YHIE	Enable interrupt generation on Y high event. Default value: 0 (0: disable interrupt request; 1: enable interrupt request on measured accel. value higher than preset threshold)
YLIE	Enable interrupt generation on Y low event. Default value: 0 (0: disable interrupt request; 1: enable interrupt request on measured accel. value lower than preset threshold)
XHIE	Enable interrupt generation on X high event. Default value: 0 (0: disable interrupt request; 1: enable interrupt request on measured accel. value higher than preset threshold)
XLIE	Enable interrupt generation on X low event. Default value: 0 (0: disable interrupt request; 1: enable interrupt request on measured accel. value lower than preset threshold)

Configuration register for Interrupt 2 source.

Table 48. Interrupt mode configuration

AOI	6D	Interrupt mode
0	0	OR combination of interrupt events
0	1	6-direction movement recognition
1	0	AND combination of interrupt events
1	1	6-direction position recognition

7.18 INT2_SRC (35h)

Table 49. INT2_SRC register

0	IA	ZH	ZL	YH	YL	XH	XL
---	----	----	----	----	----	----	----

Table 50. INT2_SRC description

IA	Interrupt active. Default value: 0 (0: no interrupt has been generated; 1: one or more interrupts have been generated)
ZH	Z high. Default value: 0 (0: no interrupt, 1: Z high event has occurred)
ZL	Z low. Default value: 0 (0: no interrupt; 1: Z low event has occurred)
YH	Y high. Default value: 0 (0: no interrupt, 1: Y high event has occurred)
YL	Y low. Default value: 0 (0: no interrupt, 1: Y low event has occurred)
XH	X high. Default value: 0 (0: no interrupt, 1: X high event has occurred)
XL	X Low. Default value: 0 (0: no interrupt, 1: X low event has occurred)

Interrupt 2 source register. Read-only register.

Reading at this address clears the INT2_SRC IA bit (and the interrupt signal on the INT 2 pin) and allows the refresh of data in the INT2_SRC register if the latched option was chosen.

7.19 INT2_THS (36h)

Table 51. INT2_THS register

0	THS6	THS5	THS4	THS3	THS2	THS1	THS0
---	------	------	------	------	------	------	------

Table 52. INT2_THS description

THS6 - THS0	Interrupt 1 threshold. Default value: 000 0000
-------------	--

7.20 INT2_DURATION (37h)

Table 53. INT2_DURATION register

0	D6	D5	D4	D3	D2	D1	D0
---	----	----	----	----	----	----	----

Table 54. INT2_DURATION description

D6 - D0	Duration value. Default value: 000 0000
---------	---

The **D6 - D0** bits set the minimum duration of the Interrupt 2 event to be recognized. Duration time steps and maximum values depend on the ODR chosen.

8 Package information

In order to meet environmental requirements, ST offers these devices in different grades of ECOPACK® packages, depending on their level of environmental compliance. ECOPACK® specifications, grade definitions and product status are available at: www.st.com. ECOPACK® is an ST trademark.

8.1 QFN 24L package information

Figure 12. QFN 24L: Mechanical data and package outline

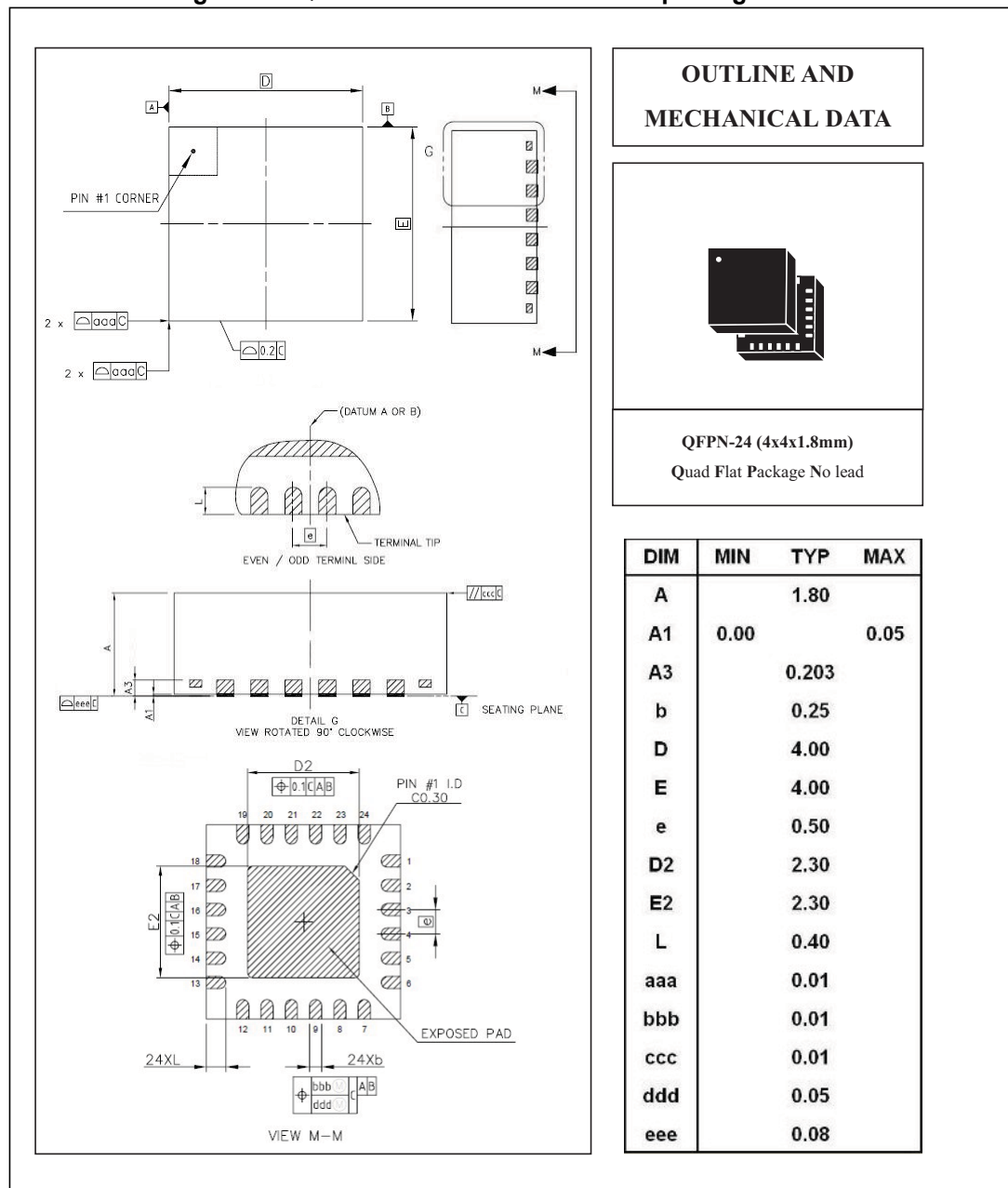

9 Soldering information

The QFPN-24 package is compliant with the ECOPACK®, RoHS and “Green” standard. It is qualified for soldering heat resistance according to JEDEC J-STD-020C, in MSL3 conditions.

For complete land pattern and soldering recommendations, please refer to the technical note TN0019 available on www.st.com.

9.1 General guidelines for soldering surface-mount MEMS sensors

The following three elements must be considered in order to adhere to common PCB design and good industrial practices when soldering MEMS sensors:

1. PCB with its own conductive layers (i.e. copper) and other organic materials used for board protection and dielectric isolation.
2. Accelerometer to be mounted on the board. The accelerometer senses acceleration, but it senses also the mechanical stress coming from the board. This stress is minimized with simple PCB design rules.
3. Soldering paste like Sn/Ag/Cu. This soldering paste can be dispensed on the board with a screen printing method through a stencil. The pattern of the soldering paste on the PCB is given by the stencil mask itself.

9.2 PCB design guidelines

PCB land and solder masking general recommendations are shown in [Figure 13](#). Refer to [Figure 12](#) for specific package size, land count and pitch.

- It is recommended to open solder mask external to PCB land;
- It is mandatory, for correct device functionality, to ensure that some clearance is present between the accelerometer thermal pad and PCB. In order to obtain this clearance it is recommended to open the PCB thermal pad solder mask
- The area below the sensor (on the same side of the board) must be defined as a keep-out area. It is strongly recommended to not place any structure on the top metal layer underneath the sensor;
- Traces connected to pads should be as symmetric as possible. Symmetry and balance for pad connection will help component self-alignment and will lead to a better control of solder paste reduction after reflow;
- For better performance over temperature it is strongly recommended not to place large insertion components like buttons or shielding boxes at distances less than 2 mm from the sensor
- Central die pad and “Pin 1 Indicator” are physically connected to GND. Leave “Pin 1 Indicator” unconnected during soldering.

9.3 PCB design rules

Figure 13. Recommended land and solder mask design for QFPN packages

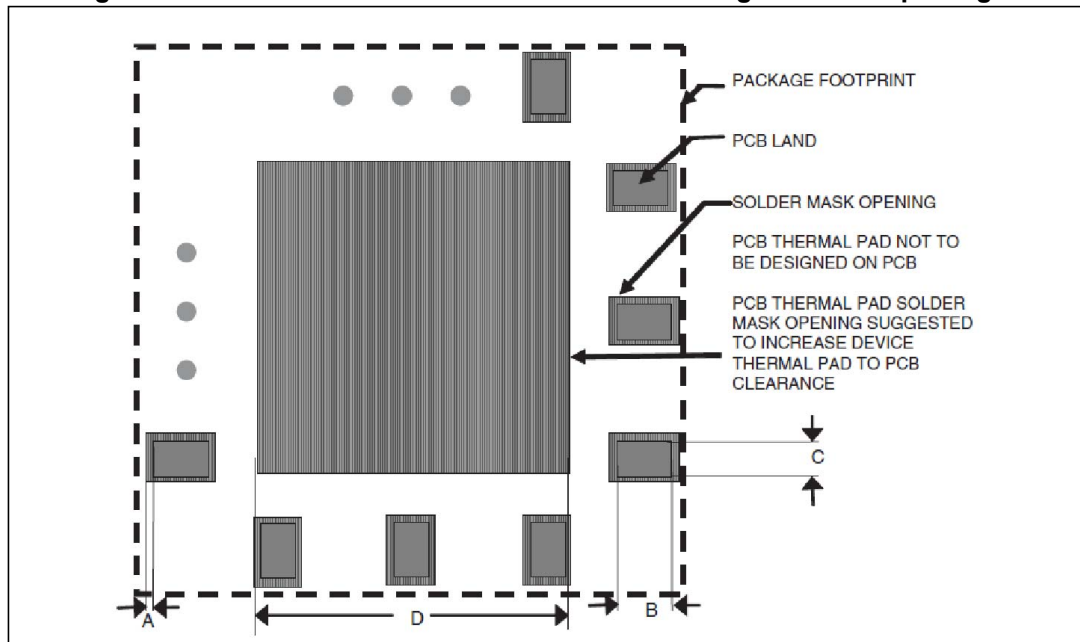

A = Clearance from PCB land edge to solder mask opening ≤ 0.1 mm to ensure that some solder mask remains between PCB pads

B = PCB land length = QFPN solder pad length + 0.1 mm

C = PCB land width = QFPN solder pad width + 0.1 mm

D = PCB thermal pad solder mask opening = QFPN thermal pad side + 0.2 mm

The thermal pad must not be soldered.

9.4 Stencil design and solder paste application

The thickness and the pattern of the soldering paste are important for the proper device mounting process

- Stainless steel stencils are recommended for solder paste application;
- A stencil thickness of 125 - 150 μm (5 - 6 mils) is recommended for screen printing;
- The final thickness of soldering paste should allow proper cleaning of flux residuals and clearance between sensor package and PCB;
- Stencil aperture should have a rectangular shape with dimension up to 25 μm (1 mil) smaller than PCB land;
- The openings of the stencil for the signal pads should be between 50% and 80% of the PCB pad area;
- Optionally, for better solder paste release, the aperture walls should be trapezoidal and the corners rounded;
- The fine pitch of the IC leads requires accurate alignment of the stencil to the printed circuit board. The stencil and printed circuit assembly should be aligned to within 25 μm (1 mil) prior to application of the solder paste.

9.5 Process considerations

- If self-cleaning solder paste is not used, it is mandatory to properly wash the board after soldering to eliminate any possible source of leakage between adjacent pads due to flux residues;
- The PCB soldering profile depends on the number, size and placement of components in the application board. The customer should use a time and temperature reflow profile that is derived from the PCB design and manufacturing specifications.

10 Revision history

Table 55. Document revision history

Date	Revision	Changes
10-Nov-2014	1	Initial release
14-Dec-2015	2	Updated <i>Figure 5: AIS3624DQ electrical connections</i>