

**B** AJ-156S

ITEM #	PART #	QTY	DESCRIPTION
1	AJ-156-11	1	HOUSING, JACK CABLE
2	AJ-156-30	1	INSERT, 6-COND
3	AP-105-5	1	STRAIN RELIEF
4	AP-116-3	1	WASHER, RUBBER
5	AP-136-8	1	NUT ADAPTER WITH GASKET
6	AP-136-6	1	CLAMP, OUTER SHELL
7	AP-136-5	1	CLAMP, SHIELD INNER
8	SEE TABLE #1	1	BUSHING
9	SEE TABLE #1	1	WASHER
10	SEE TABLE #1	1	SPRING
11	AP-116-6	1	STUD

TABLE #1				
PART #	CABLE Ø	BUSHING	WASHER	SPRING
AJ-156S/12-1	Ø .165 ± .010	AP-116-17	AP-116-2	AP-116-4
AJ-156S/12-2	Ø .228 ± .010	AP-116-18	AP-116-2	AP-116-4
AJ-156S/12-3	Ø .250 ± .010	AP-116-8	AP-116-2	AP-116-4
AJ-156S/12-4	Ø .290 ± .010	AP-116-19	AP-116-2	AP-116-4
AJ-156S/12-5	Ø .320 ± .010	AP-116-20	AP-116-22	AP-116-21

NOTES:  
1) MARK PART NUMBER & MANUFACTURER'S NAME, LOCATED APPROX AS SHOWN

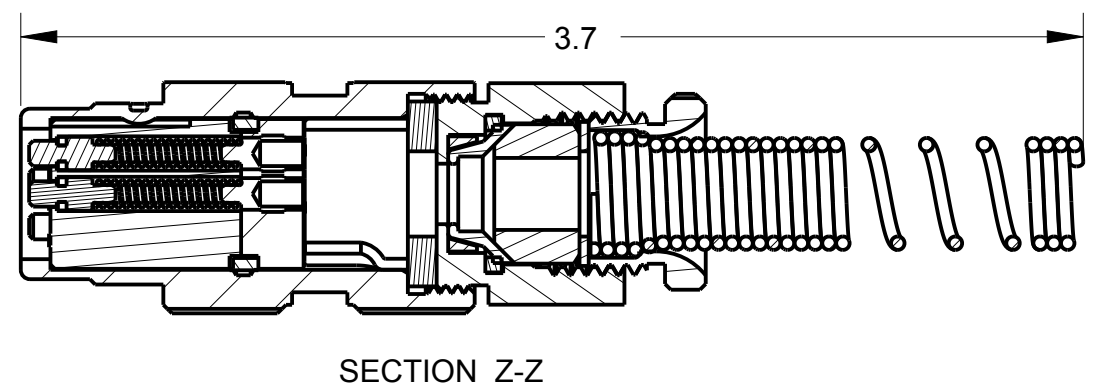
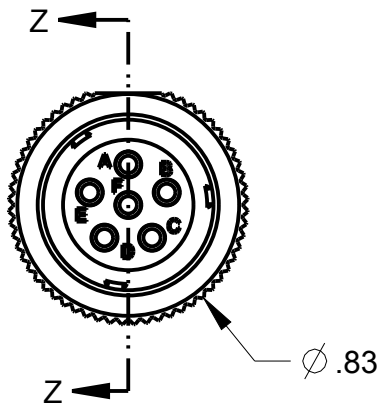
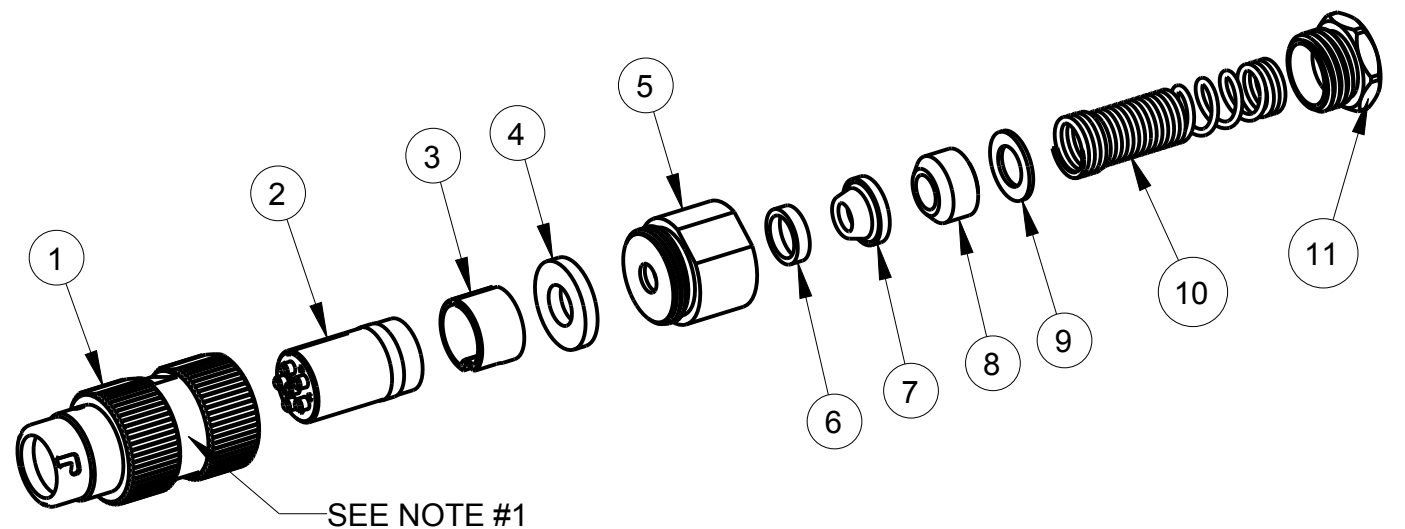

THIS DOCUMENT CONTAINS PROPRIETARY INFORMATION OF NEXUS, INCORPORATED AND SUCH INFORMATION MAY NOT BE DISCLOSED TO OTHERS FOR ANY PURPOSE OR USED FOR ANY PURPOSE WITHOUT THE WRITTEN CONSENT OF NEXUS.

LET.	REVISION	CN #	DATE	CHK.
B	ADD: AJ-156S; BILL OF MATERIAL	213	10/8 2014	HR
A	NEW RELEASE	135	7/26 2012	HR

DWN.BY	HR	DATE	7/26/12
CHECKED BY		DATE	
APPR.BY		DATE	

UNLESS OTHERWISE SPECIFIED:  
DIMENSIONS ARE IN INCHES &/OR (mm)  
TOLERANCES:  
DECIMAL: .XX[X.X] .XXX[X.XX]  
± .01[0.3] ± .003[0.08]  
FRACTION: X/X ANGLER: X  
± 1/64 ± .5°

MATERIAL	
FINISH	
WEIGHT —	SCALE = 2.00 :1
TITLE <b>JACK 6-PIN AUDIO CRIMP SLEEVE, SHIELDED</b>	
DO NOT SCALE DWG.	SHEET 1 OF 1

**NEXUS**  
STAMFORD, CONN

SIZE **B** DWG. NO. **AJ-156S**