

ITEM #	PART #	QTY	DESCRIPTION	MATERIAL
1	AJ-156-11	1	HOUSING, JACK CABLE	#303 STAINLESS STEEL
2	AJ-165-30	1	INSERT 5-COND, CRIMP SLEEVE	DIALLYPHTHALATE, TYPE SDGF & GOLD PLATED BRASS
3	AP-105-5	1	STRAIN RELIEF	NYLON
4	AP-116-3	1	WASHER	RUBBER
5	AP-136-8	1	NUT ADAPTER	BRASS, BLACK CHROME
6	AP-136-6	1	CLAMP SHIELD, OUTER	NICKEL PLATED BRASS
7	AP-136-5	1	CLAMP SHIELD, INNER	NICKEL PLATED BRASS
8	SEE TABLE #1	1	BUSHING	RUBBER
9	SEE TABLE #1	1	WASHER	STAINLESS STEEL
10	SEE TABLE #1	1	SPRING	#302 STAINLESS STEEL
11	AP-116-6	1	STUD	ANODIZED ALUMINUM ALLOY

C AJ-165S

TABLE #1				
PART NUMBER	CABLE DIA.	BUSHING	WASHER	SPRING
AJ-165S/13-1	∅ .165 ± .010	AP-116-17	AP-116-2	AP-116-4
AJ-165S/13-2	∅ .228 ± .010	AP-116-18	AP-116-2	AP-116-4
AJ-165S	∅ .250 ± .010	AP-116-8	AP-116-2	AP-116-4
AJ-165S/13-4	∅ .290 ± .010	AP-116-19	AP-116-2	AP-116-4
AJ-165S/13-5	∅ .320 ± .010	AP-116-20	AP-116-22	AP-116-21

NOTES:
1) MARK PART NUMBER & MANUFACTURERS NAME, LOCATED APPROXIMATELY AS SHOWN.

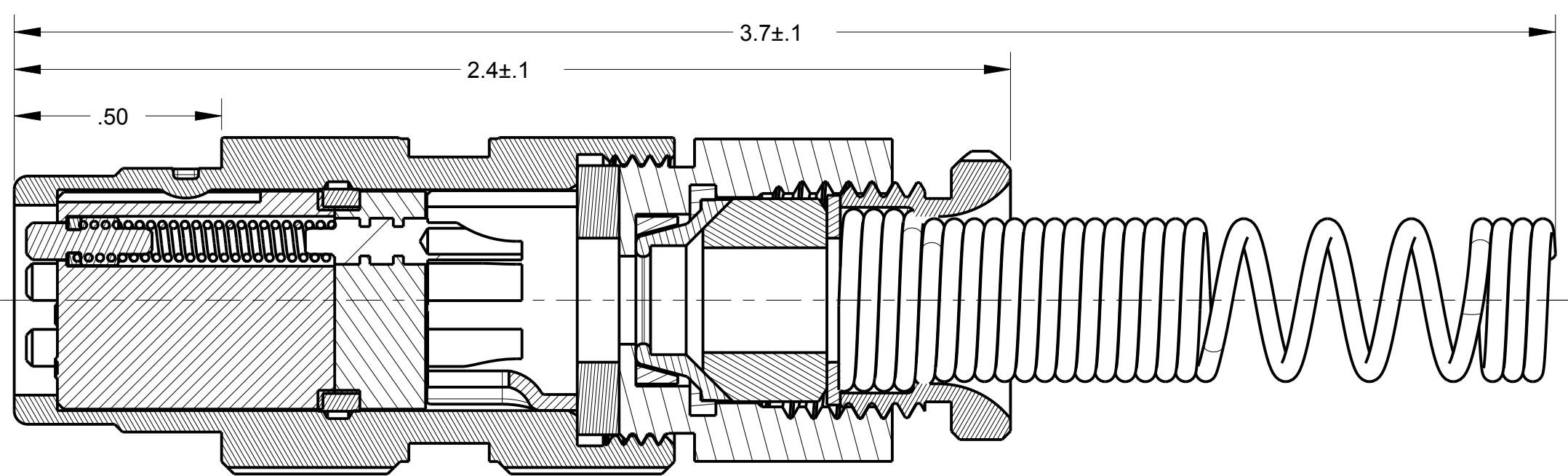
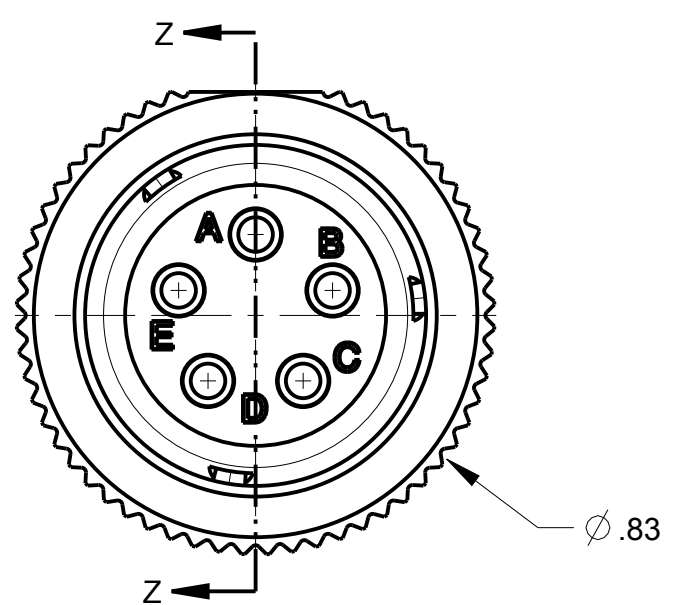
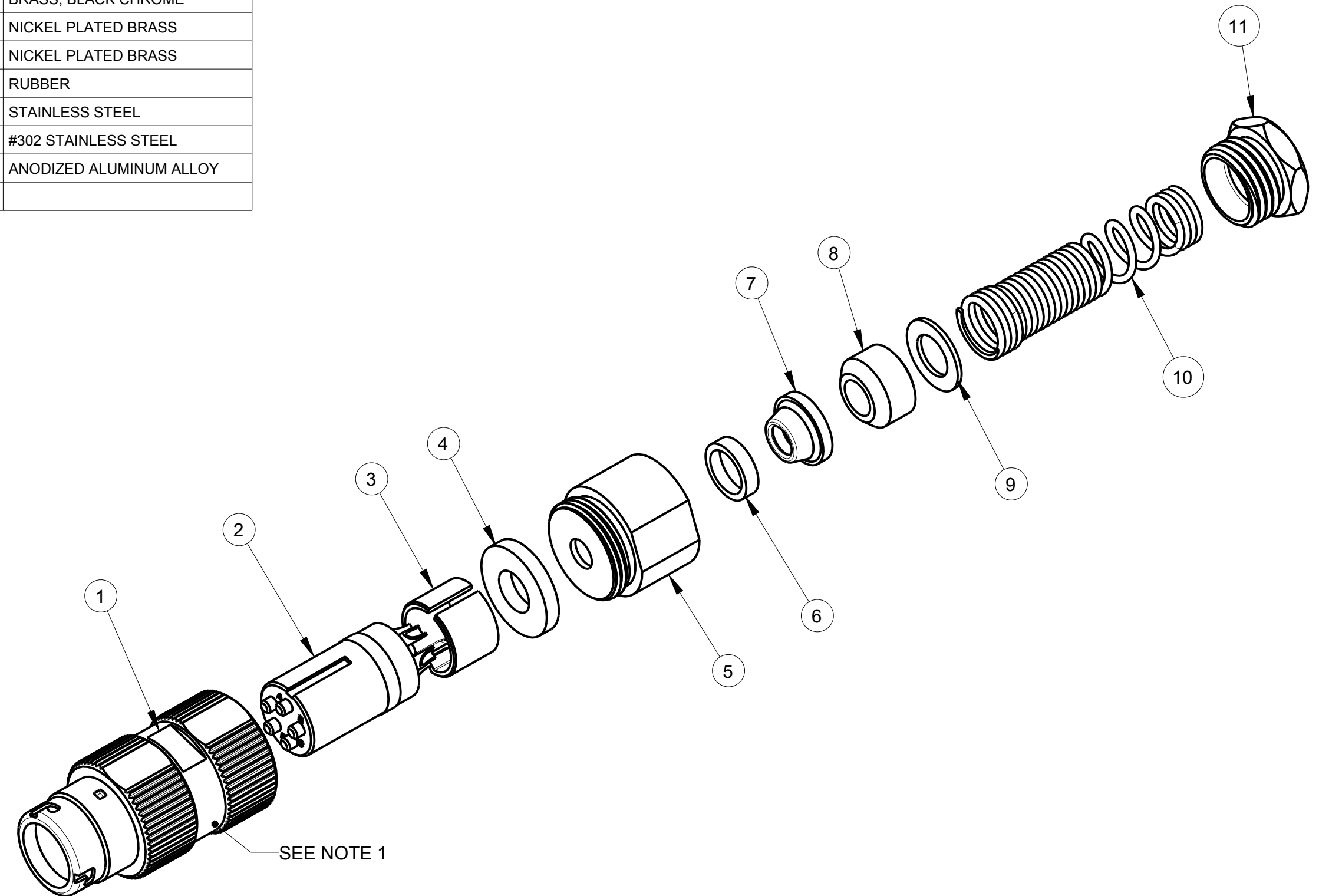

SECTION Z-Z

THIS DOCUMENT CONTAINS PROPRIETARY INFORMATION OF NEXUS, INCORPORATED AND SUCH INFORMATION MAY NOT BE DISCLOSED TO OTHERS FOR ANY PURPOSE OR USED FOR ANY PURPOSE WITHOUT THE WRITTEN CONSENT OF NEXUS.

DWN. BY		HR	DATE		6/10/14	MATERIAL	
CHECKED BY			DATE			FINISH	
APPR. BY			DATE			WEIGHT	SCALE = 2.00 :1
UNLESS OTHERWISE SPECIFIED DIMENSIONS ARE IN INCHES & OR (mm)						TITLE	
TOLERANCES:						JACK 5-PIN AUDIO, CRIMP SLEEVE	
DECIMAL:						NEXUS STAMFORD, CONN	
FRACTION: ±XXX ±.XXX						SIZE DWG. NO.	
ANGLE: ±X° ±X'						C AJ-165S	
DO NOT SCALE DWG.		SHEET 1 OF 1					

LET.	REVISION	CN #	DATE	CHK
A	NEW RELEASE	202	6/10/2014	HR