

Specification

Part No. : **AJA.02**

Product Name : Cipher 2.4GHz Flexible Dipole Antenna with
Integral Anti-Jamming Out-of-Band Filter

Features : Suppresses Out-of-Band Interference
Frequency Range: 2400-2500 MHz
Flexible
Embedded Dielectric Ceramic Filter
Omni-directional
Linear Polarization
Cable: 1.13mm Micro Coax Cable
Connector: IPEX MHFI connector (U.FL compatible)
Custom Cable Length and Connector Optional
Dimensions: 8.8*13*194 mm
RoHS Compliant



1. Introduction

The Taoglas Cipher AJA.02 2.4GHz flexible anti jamming antenna is ideal for use in unmanned aerial vehicle (UAV) applications. It has an excellent efficiency of over 60% in the 2.4 to 2.5 GHz range and is small, lightweight and easy to install. The flexible cable allows it to be wrapped to a sub-structure, such as a plastic support leg or wing of a UAV.

The antenna includes an embedded ceramic dielectric filter which helps preserve maximum reception range and signal quality by preventing out-of-band signals from overdriving the LNA in your receiver. Note due to the inherent nature of all antennas in-band noise cannot be filtered out. In that case keep the antenna as far away from the source of interference as possible.

The AJA.02 antenna has a near-isotropic radiation pattern allowing for good coverage at most angles and when mounted in pairs, especially at 90 degrees to each other, can allow for radio transmission and reception without dead spots.

The antenna length and connector can be customized, or other versions designed specifically to your needs. Please contact your regional Taoglas sales office to order or for more information.

2. Specification Table

ELECTRICAL	
Frequency Range (MHz)	2400~2500 MHz
Return Loss (dB)	< -10 dB
Efficiency (%)	67.32 %
Peak Gain	1.74 dBi
Polarization	Linear
Radiation	Omni-directional
Impedance	50 Ω
Input Power (Max)	10 W
MECHANICAL	
Dimensions	8.8*13*194 mm
Cable	1.13mm micro coaxial cable
Connector	IPEX MHF
Weight	2.3g
Antenna Housing Material	ASA
ENVIRONMENTAL	
Operating Temperature	-40°C to 85°C
Storage Temperature	-40°C to 85°C
Humidity	Non-condensing 65°C 95% RH

3. Antenna Characteristics

3.1 Antenna Set Up

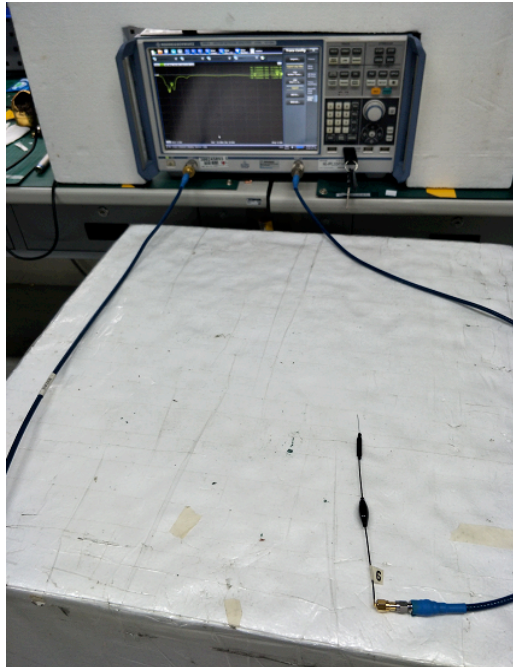

3.2 Return Loss

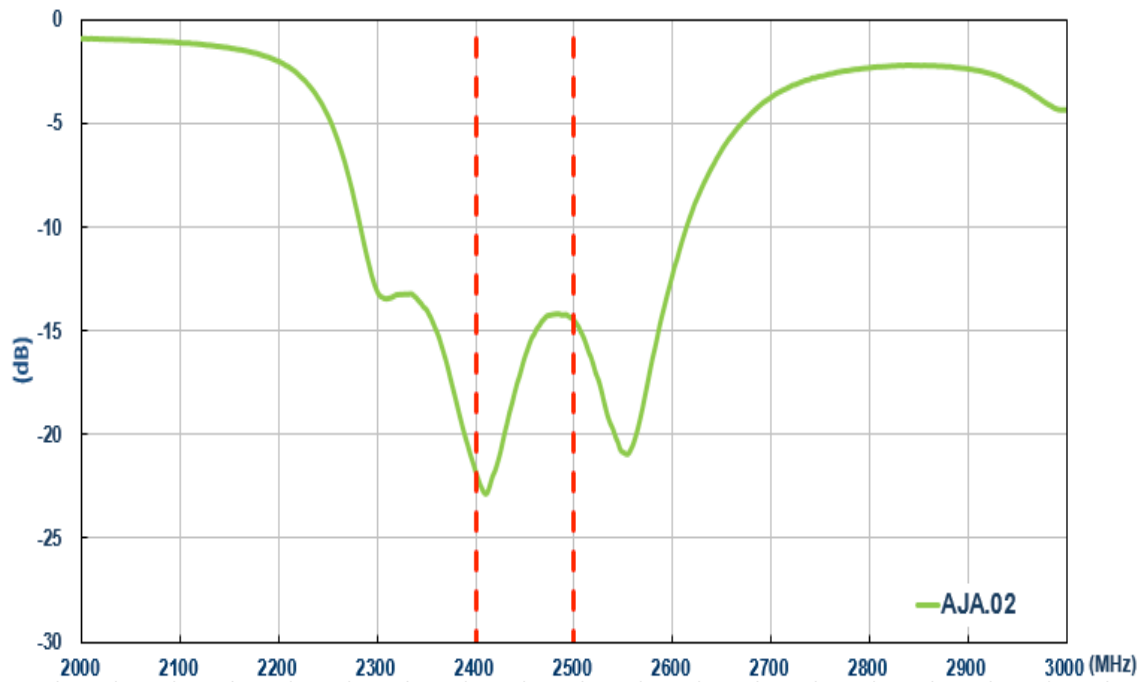

3.3 Insertion loss

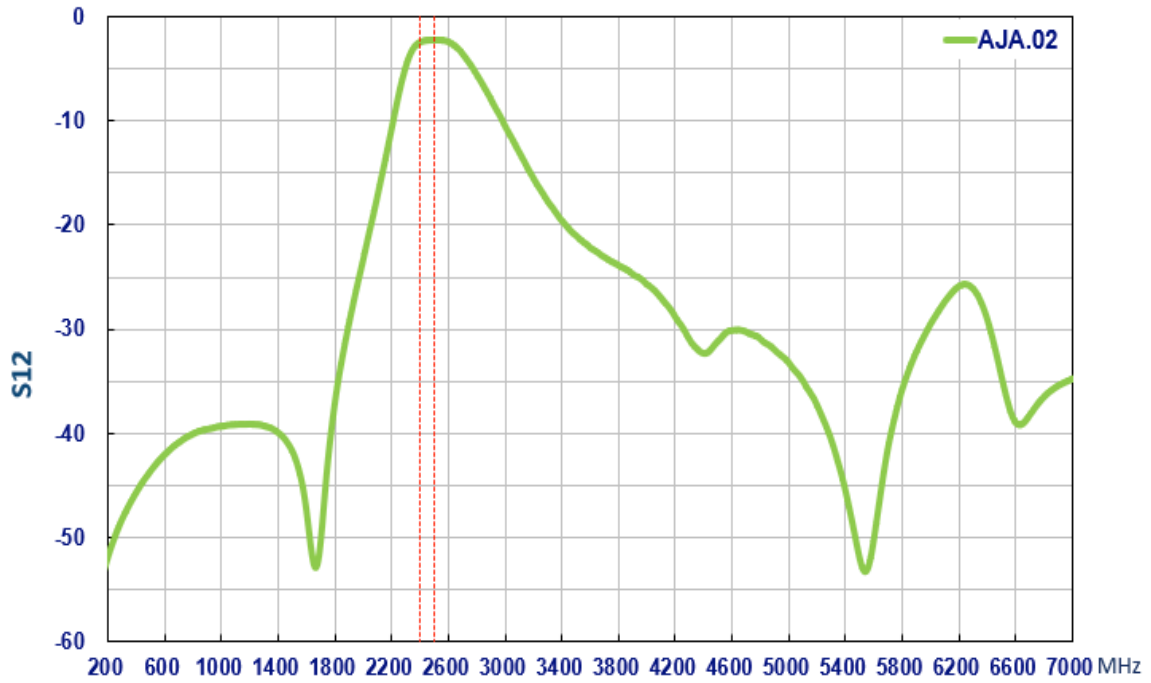

3.4 Efficiency

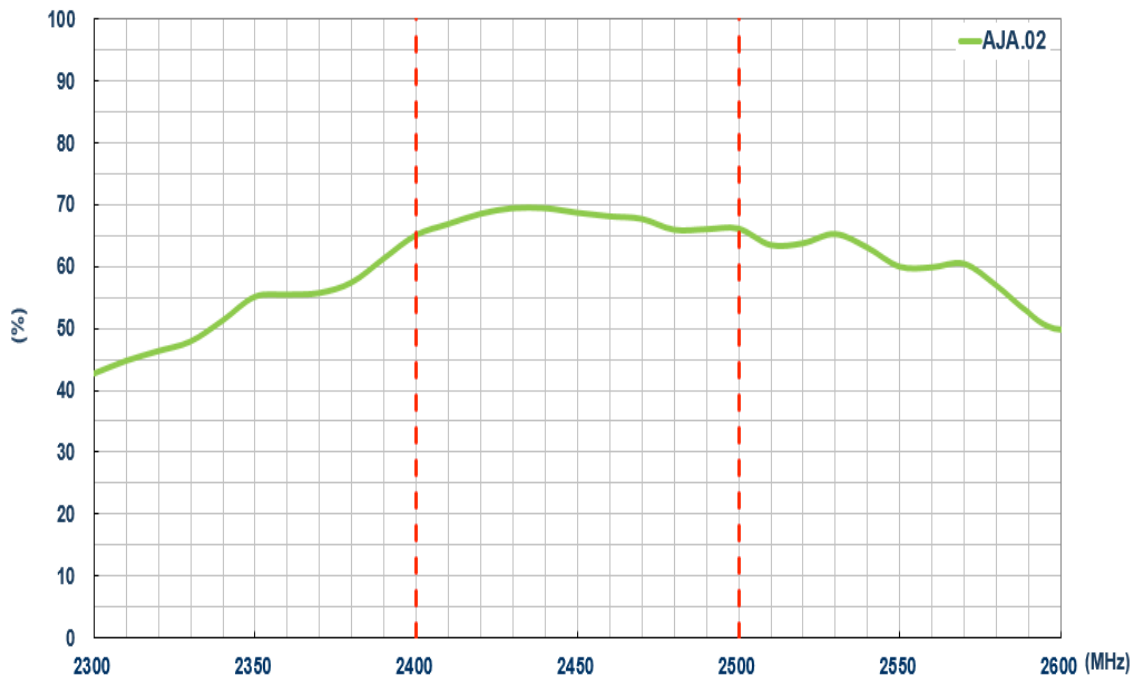

3.5 Average Gain

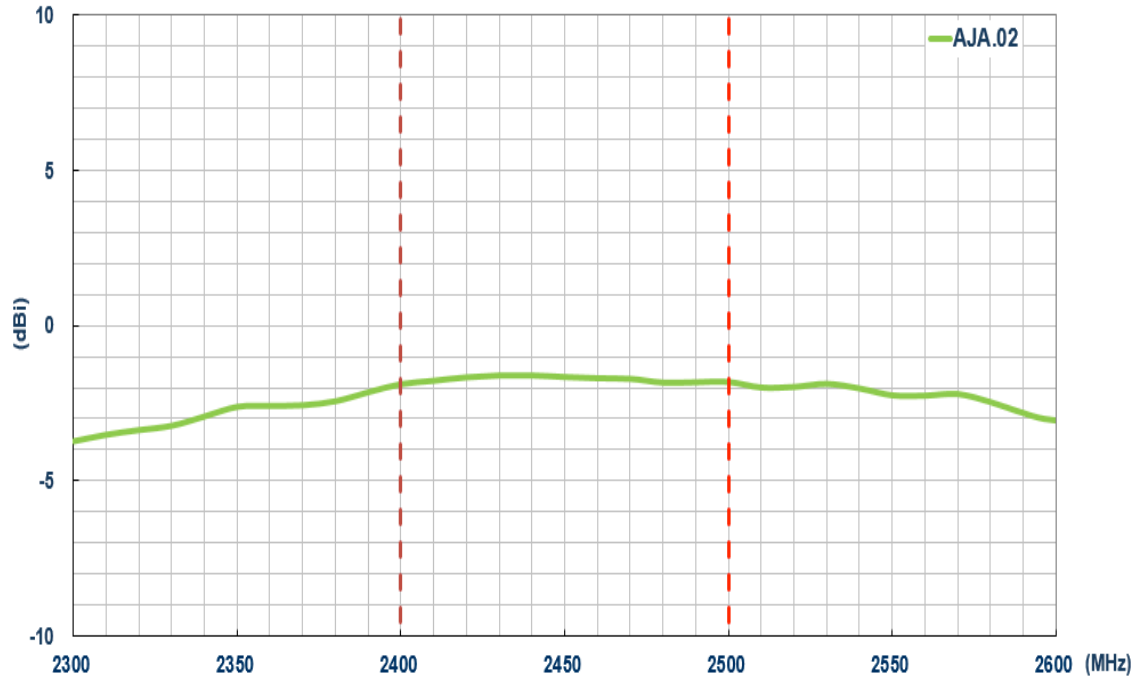

3.6 Peak Gain

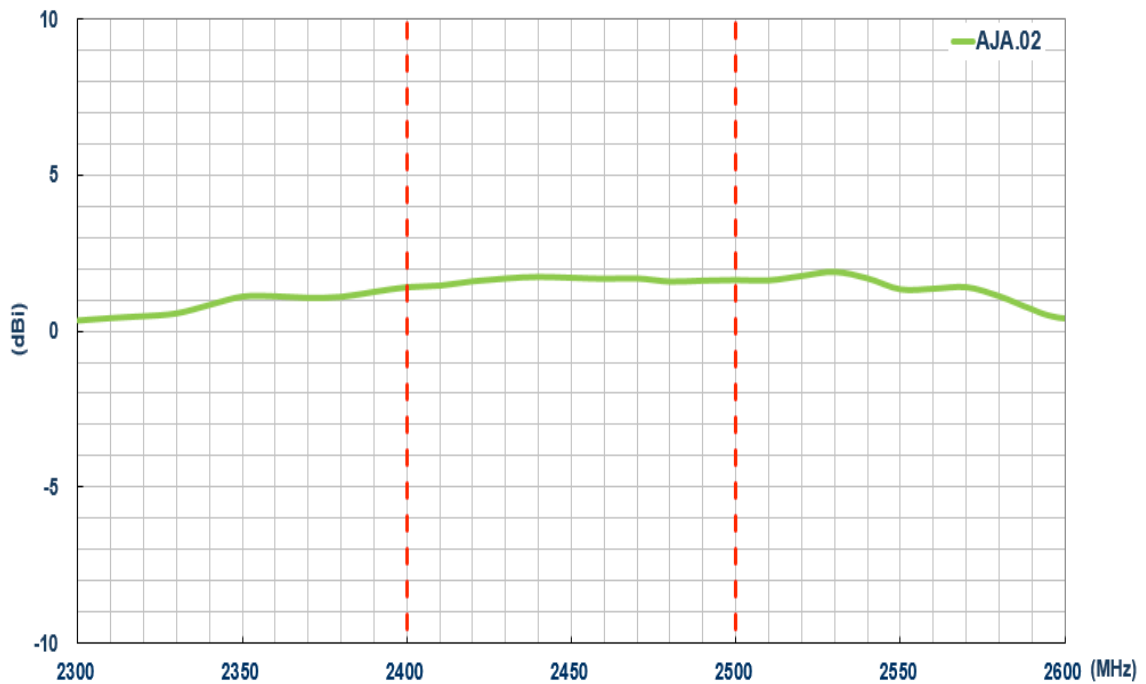

4. Antenna Radiation Patterns

4.1 Antenna Setup

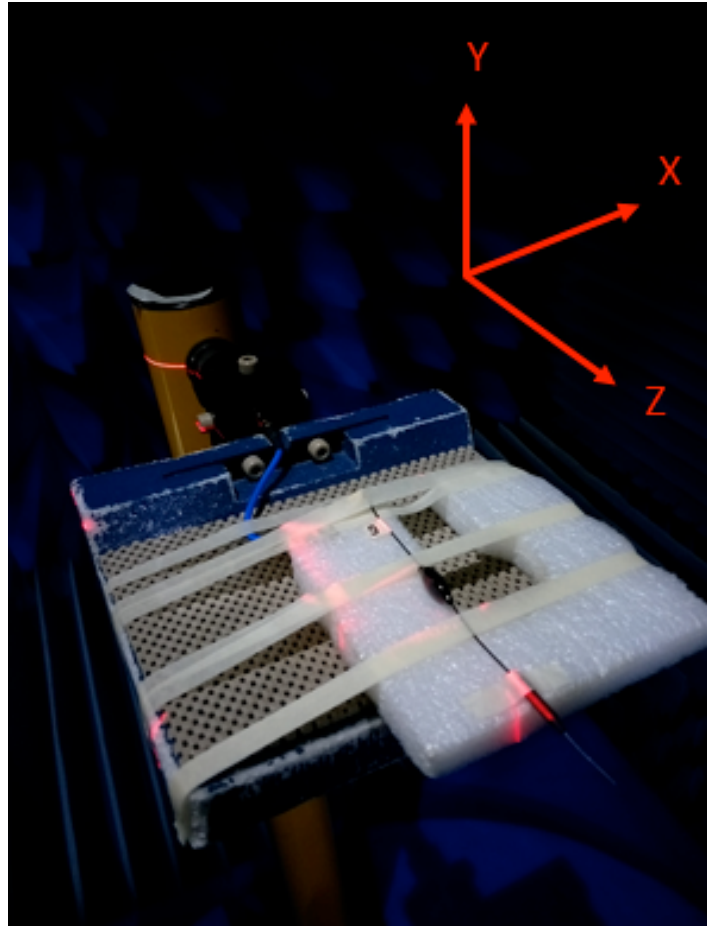

4.2 Antenna Radiation Patterns

XY- Plane

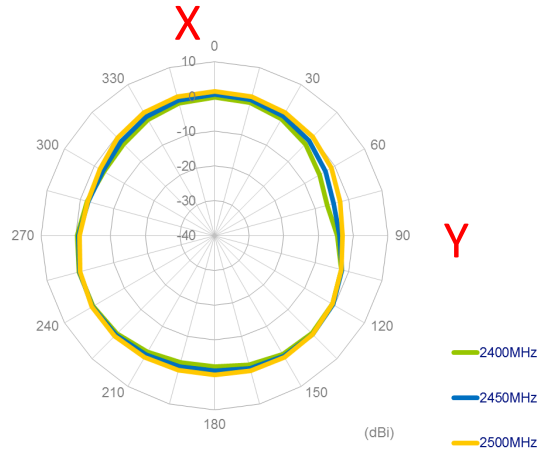

XZ-Plane

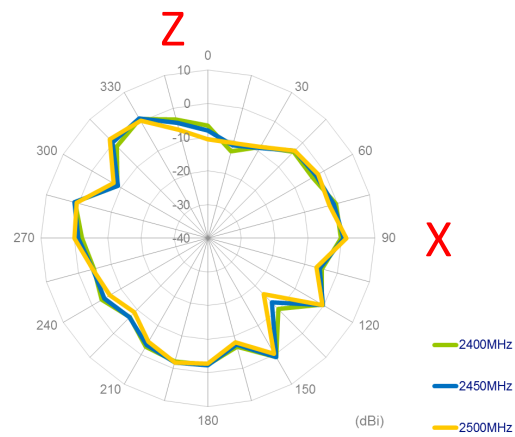

YZ-Plane

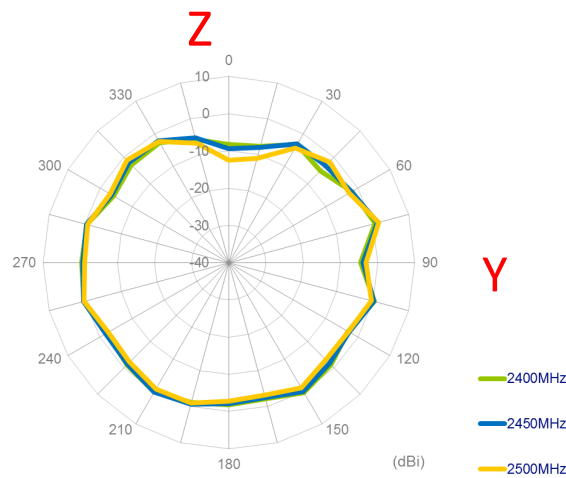

4.3 3D Radiation Pattern

2400MHz

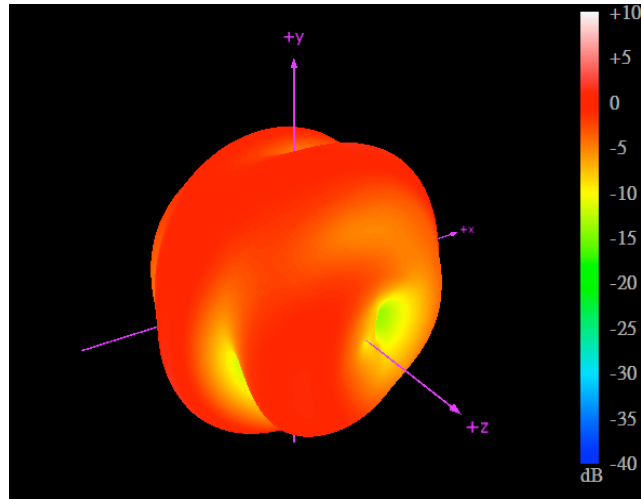

2450MHz

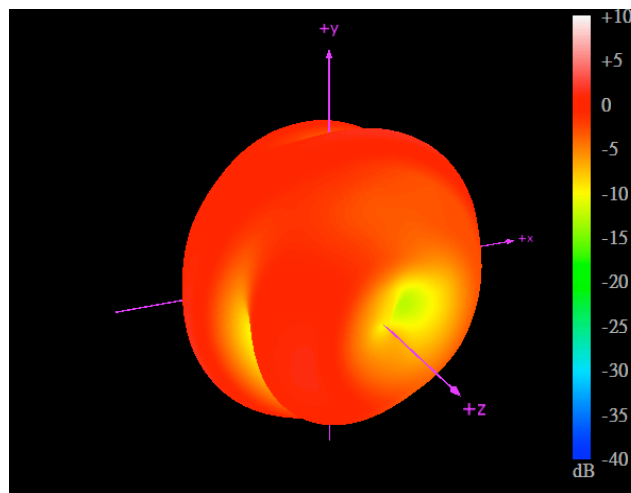

2500MHz

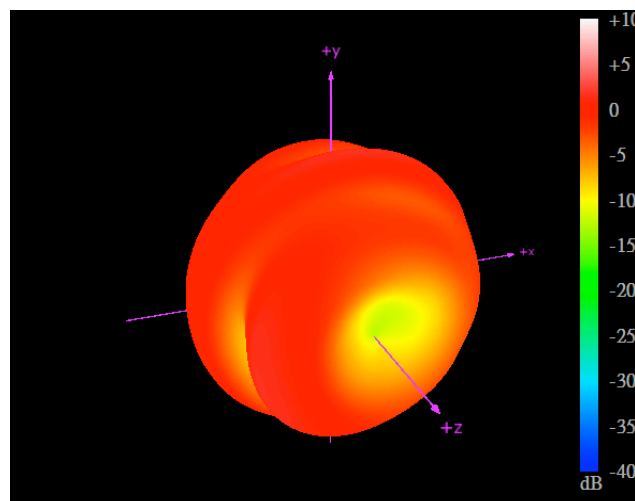

5. Mechanical Drawing (Unit: mm)

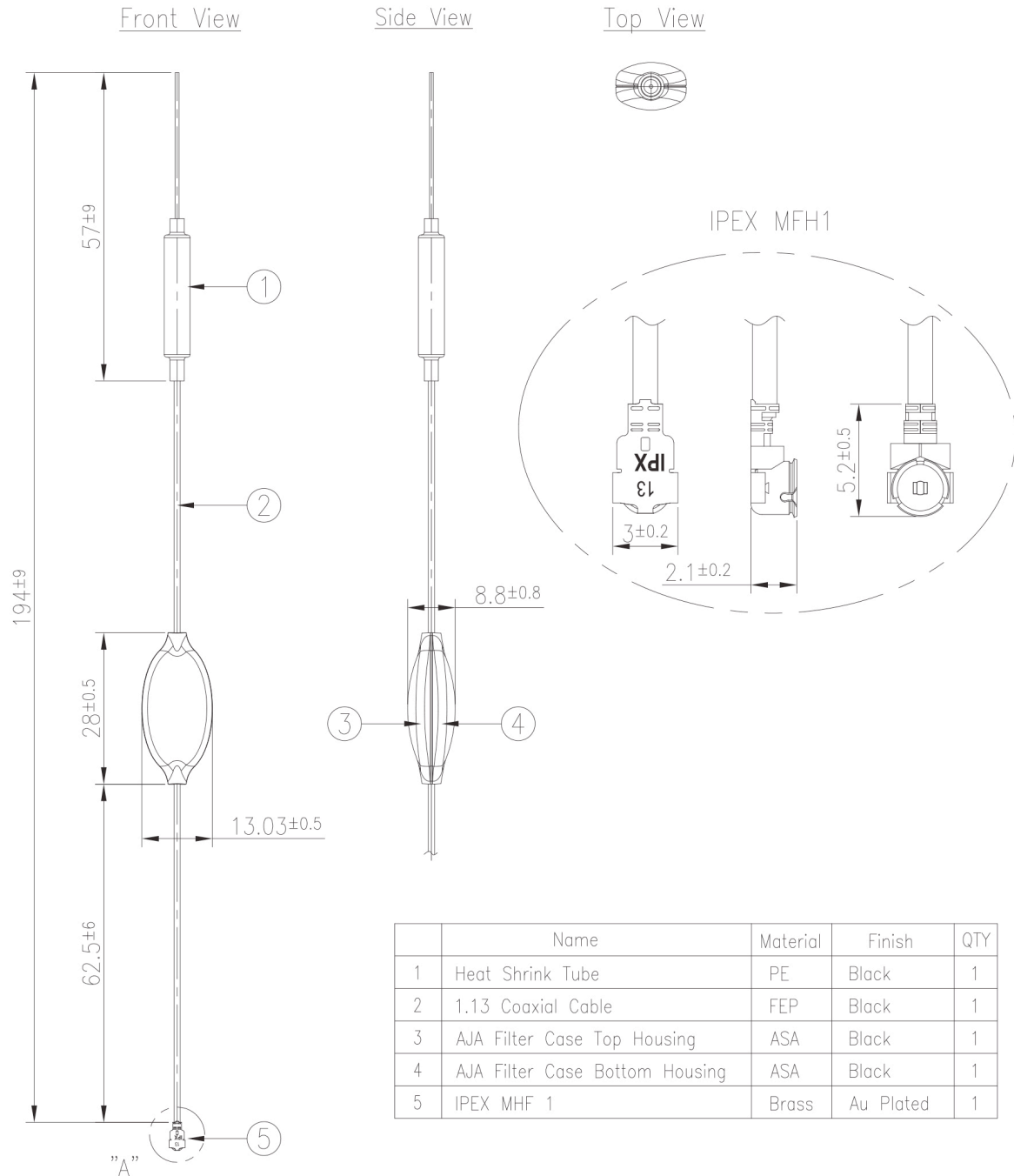

6. Installation

6.1 Mounting

The AJA.02 2.4GHz antenna can be mounted with cable ties or adhesive on the housing of ceramic dielectric filter.

Ideally, the antenna should be mounted close to the exterior of the UAV device to allow it to radiate outwards and receive signals without obstruction from internal device components.

For maximum antenna efficiency, plastic, fiberglass, or carbon-fiber should be used as mounting surfaces. The antenna should be kept as far away from metal and radiating electronic circuits as possible.

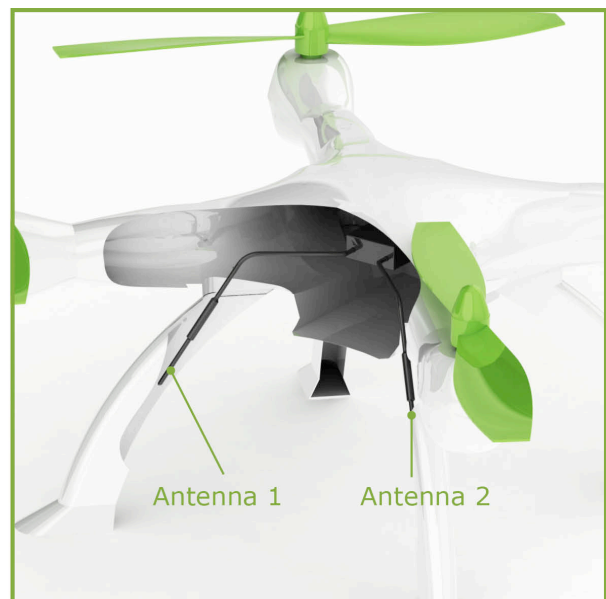
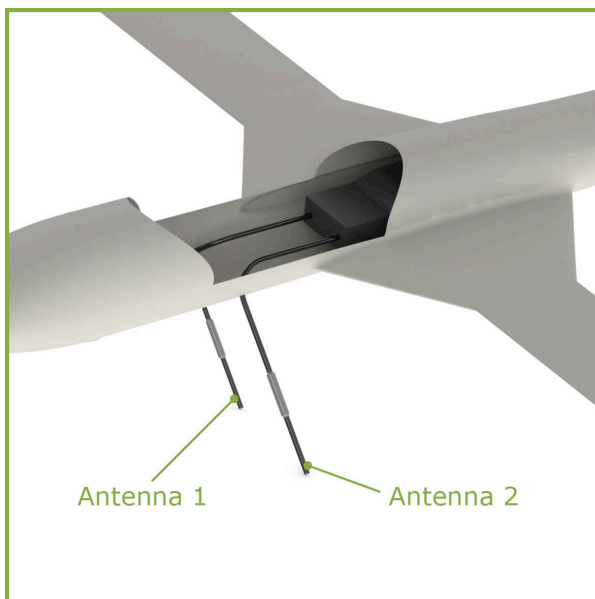

6.2 Polarization and Alignment

The AJA.02 2.4GHz antenna has linear polarization. The alignment of its polarization (horizontal or vertical) depends on how it is mounted in your frame of reference.

To receive signals with the widest possible range of (linear) polarization, the antennas in a two-antenna receiver system should be oriented 90 degrees from one another. This configuration minimizes the dead spots that often occur in UAV applications.

6.3 Connector Precautions

Plug Usage Precautions:

- 1) To disconnect connectors, insert the end portion of the I-PEX under the connector flanges and pull off vertically, in the direction of the connector mating axis.
- 2) To mate the connectors, the mating axes of both connectors must be aligned and the connectors can be mated. The "click" will confirm fully mated connection. Do not attempt to insert on an extreme angle.

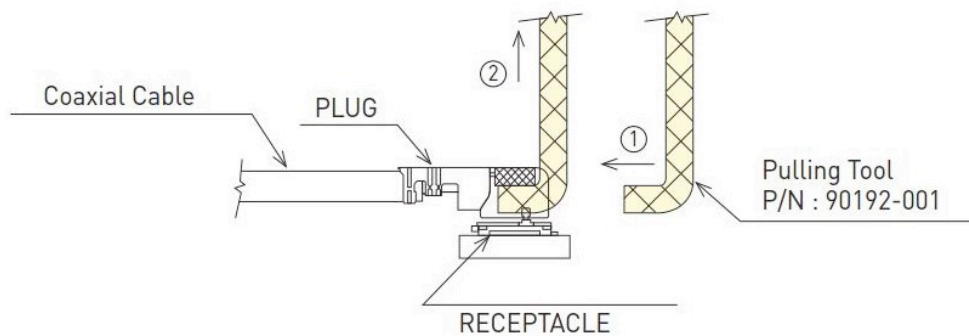

Pull forces on the cable after connectors are mated.

After connectors are mated, do not apply a load to the cable in excess of the values indicated in the diagram below.

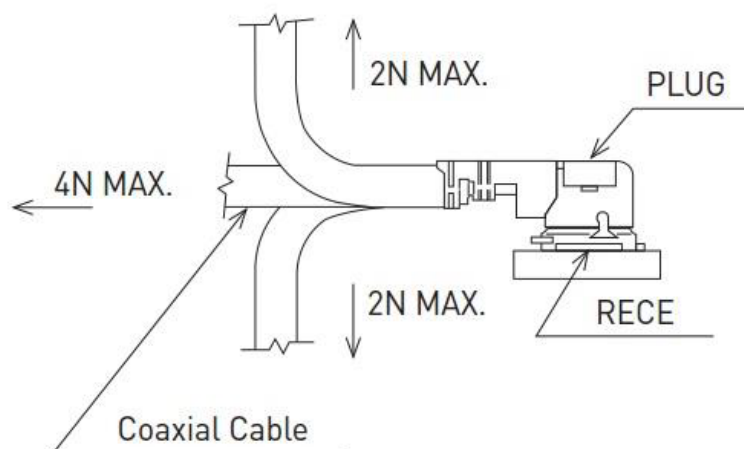

7. Packaging

10 pcs AJA.02 per PE bag
 PE Bag Dimensions - 130 x 230mm
 Weight - 27g

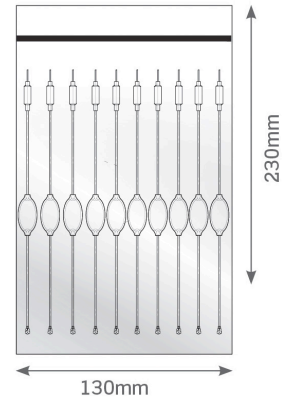

10 PE bags per large PE bags
 100 pcs AJA.02 per large PE bags
 large PE bags Dimensions - 230 x 330mm
 Weight - 290g

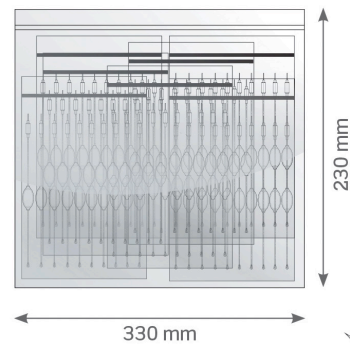

10 Large PE bags per carton
 1000 pcs AJA.02 per carton
 Carton Dimensions - 360 x 310 x 160mm
 Weight - 2.74kg

