

1. SPECIFICATION

AKB-1508A-P

ITEM		SPECIFICATIONS	
01	Type	Dynamic Speaker	
02	Dimension	External diameter 15 mm	
03	Rated Input Power	0.3 W	
04	Max. Input Power	0.5 W for 1 minute	
05	Impedance	$8\Omega \pm 15\%$ at 1 KHz 1V	
06	Resonance Frequency (Fo)	2000 Hz \pm 20% at Fo, 1V	
07	Sound pressure level	90 dB(0.3W/0.1M) \pm 3 dB	at AVE 2.0, 2.5, 3.0, 4.0 KHz.
08	Frequency Range	Fo – 20 K Hz	
09	Total Harmonics Distortion	Max 10 % at 2 KHz, 0.1W.	
10	Magnet	Rare earth permanent (NdFeB) magnet Φ 6.95 x 1.0 mm	
11	Weight	1.6 g \pm 0.2 g	
12	Appearance	Should not exist any obstacle to be harmful to normal operation; damages, cracks, rusts and distortions, etc.	
13	Operation Test	Must be normal at program source 0.3W	
14	Buzz, Rattle, etc.	Should not be audible at 1.55V sine wave between Fo to 2KHz	
15	Polarity	When positive voltage is applied to the terminal marked (+), diaphragm should move to the front.	
16	Terminal Strength	Capable of withstand 1kg load for 15 seconds without resulting in any damage or rejection.	
17	Temperature	Operating temperature: -20°C to +60°C Storage temperature: -30°C to +70°C	

REV NO.	REVISION NOTE	APPROVAL	DATE
---------	---------------	----------	------

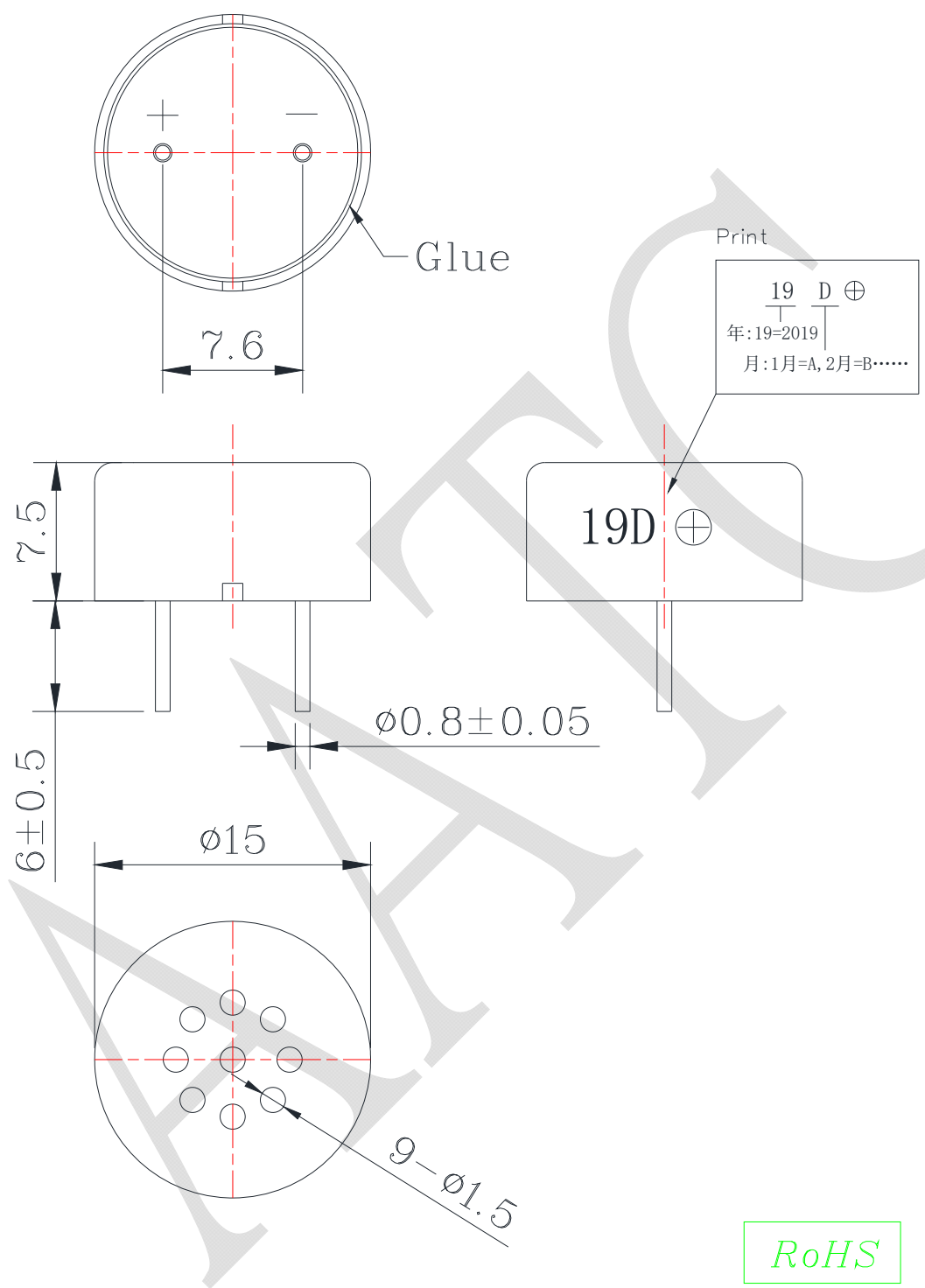

TITLE: DYNAMIC SPEAKER		DRAWN: <i>Zack</i> 2020/07/08	SCALE: 1:1	SHEET: 1 : 1
PART NO. AKB-1508A-P	3	DESIGNED: R & D OF AAT	UNITS: mm	
DWG NO. USM15B-8-A1		CHECKED:	TOLERANCE ± 0.5	
		APPROVAL:	FIRST ANGLE PROJECTION	
	REV	MATERIAL: PBT		



ADVANCED ACOUSTIC TECHNOLOGY CORPORATION