

1. SPECIFICATION

AKR-15110806-PAM-1PV

ITEM		SPECIFICATIONS	
01	Type	Dynamic Speaker	
02	Dimension	External diameter 15 x 11 mm	
03	Rated Input Power	0.6 W	
04	Max. Input Power	1.0 W for 1 minute	
05	Impedance	$8\Omega \pm 15\%$ at 2.0KHz 1V	
06	Resonance Frequency (Fo)	650 Hz \pm 20% at Fo, 1V	
07	Sound pressure level	85 dB(0.6W/0.1M) \pm 3 dB	at AVE 0.8, 1.0, 1.2, 1.5 KHz.
08	Frequency Range	Fo – 10 K Hz	
09	Total Harmonics Distortion	Max 10 % at 1 KHz, 0.89V.	

REV NO.	REVISION NOTE	APPROVAL	DATE
---------	---------------	----------	------

Recommended PAD LAYOUT

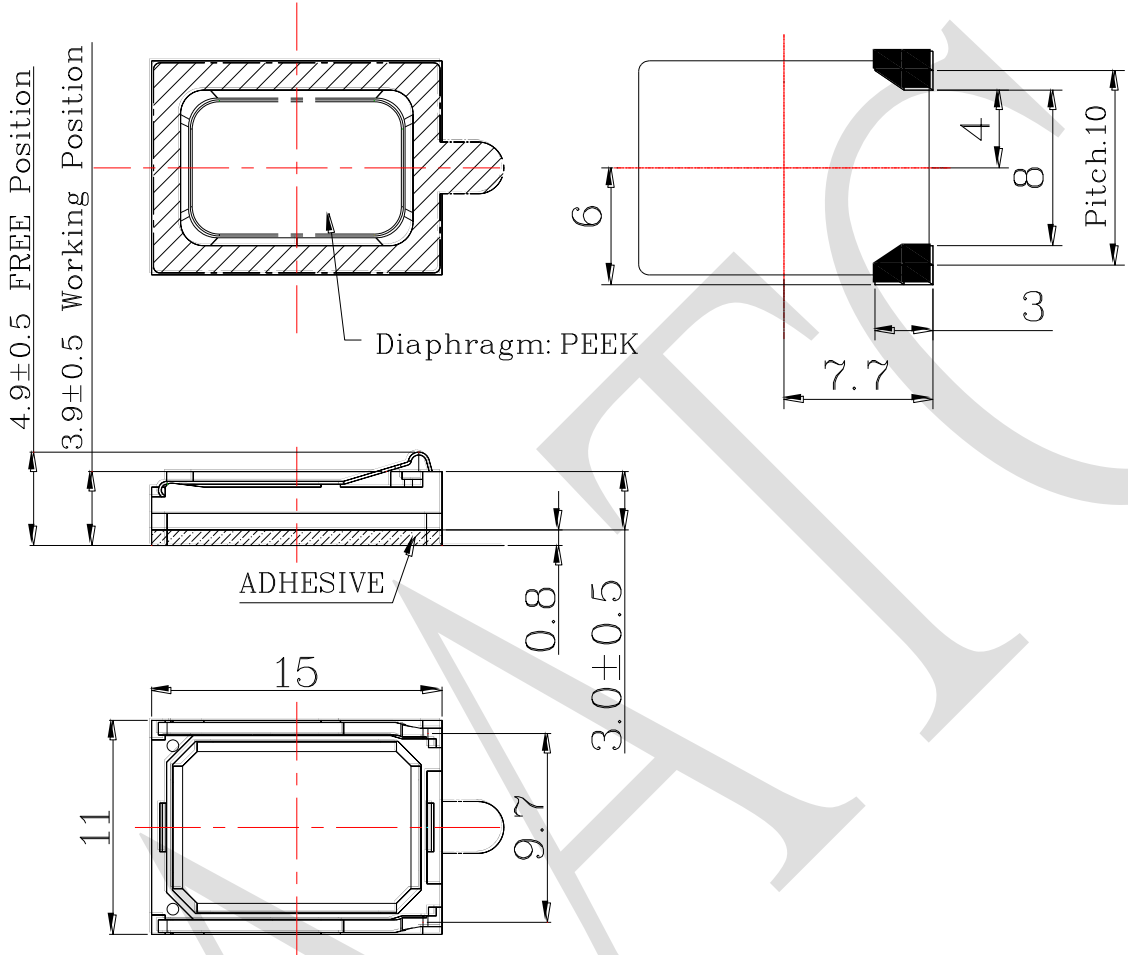

RoHS

TITLE: DYNAMIC SPEAKER		DRAWN: Moose	2016-04-12	SCALE: 1:1	SHEET: 1 : 1
PART NO. AKR-15110806-PAM-1PV		DESIGNED: R & D OF AAT	UNITS: mm		
DWG NO. *****		CHECKED:	TOLERANCE ± 0.5		
REV 1		APPROVAL:	UNLESS OTHERWISE SPECIFIED:		
		MATERIAL: PBT	ONE PLACE DECIMAL ± ***		
			TWO PLACE DECIMAL ± ***		
			THREE PLACE DECIMAL ± ***		



ADVANCED ACOUSTIC TECHNOLOGY CORPORATION