

Description

The AL3069 is a high-efficiency four-channel boost controller for WLED backlight applications. It operates over a wide input voltage range, from 4.5V to 60V.

The current of the four channels is simply programmed from 20mA to 400mA with an external resistor. The current match between any channels is $\pm 0.5\%$ (typical). Its operating frequency can be adjusted from 0.1MHz to 1MHz.

The AL3069 can support two independent dimming modes: direct PWM dimming and PWM to analog dimming. This function makes AL3069 flexible to design in different dimming applications.

Robust protection features include cycle by cycle current limit, soft-start, UVLO, programmable OVP, OTP, open/short LED protection, Schottky diode short and open protection, inductor short-circuit protection and V_{OUT} short protection.

The IC is available in SO-16 package.

Features

- Input Voltage Range: 4.5V to 60V
- Drivers up to Four Strings in Parallel, 250mA per String, 400mA Pulse Current
- Typical $\pm 0.5\%$ Current Matching
- Low Ripple for Low BOM Cost
- 4kV HBM ESD Class
- High Voltage Pins CS and OVP for Safety Test
- Supports Direct PWM Dimming, PWM to Analog Dimming
- Minimum PWM Dimming Duty Cycle Can Be 1/5,000 at 100Hz Dimming Frequency
- LED Open/Short Protection
- Schottky Diode/Inductor Short-Circuit Protection
- Built-in OCP, OVP, OTP, UVLO, V_{OUT} Short/Schottky Diode Open Protection
- **Totally Lead-Free & Fully RoHS Compliant (Notes 1 & 2)**
- **Halogen and Antimony Free. "Green" Device (Note 3)**
- **For automotive applications requiring specific change control (i.e. parts qualified to AEC-Q100/101/104/200, PPAP capable, and manufactured in IATF 16949 certified facilities), please [contact us](https://www.diodes.com) or your local Diodes representative.**
<https://www.diodes.com/quality/product-definitions/>

- Notes:
1. No purposely added lead. Fully EU Directive 2002/95/EC (RoHS), 2011/65/EU (RoHS 2) & 2015/863/EU (RoHS 3) compliant.
 2. See <https://www.diodes.com/quality/lead-free/> for more information about Diodes Incorporated's definitions of Halogen- and Antimony-free, "Green" and Lead-free.
 3. Halogen- and Antimony-free "Green" products are defined as those which contain <900ppm bromine, <900ppm chlorine (<1500ppm total Br + Cl) and <1000ppm antimony compounds.

Pin Assignments

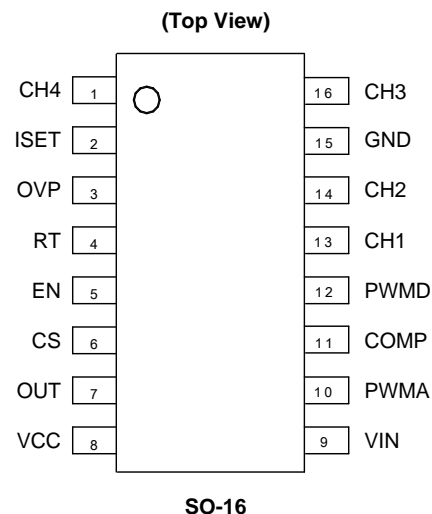

Applications

- LCD monitors
- LCD display modules
- LCD TVs

Typical Applications Circuit

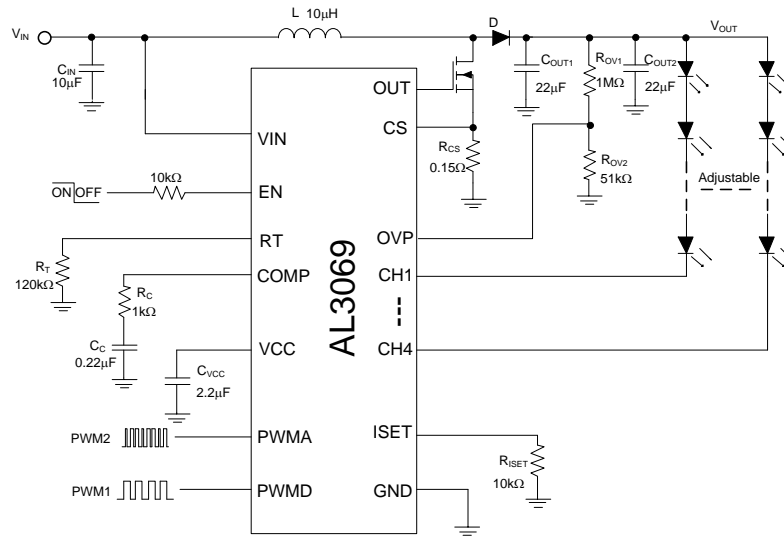

Pin Descriptions

Pin Number	Pin Name	Function
1	CH4	LED current sink 4. Leave the pin open directly if not used.
2	ISET	LED current set pin. The corresponding maximum current of all four strings is set through connecting a resistor from this pin to GND.
3	OVP	Overvoltage protection pin. When the OVP pin voltage exceeds 2.0V, the OVP is triggered and the power switch is turned off. When the OVP pin voltage drops below Hysteresis voltage, the OVP is released and the power switch will resume normal operation.
4	RT	Frequency control pin.
5	EN	ON/OFF control pin. Forcing this pin voltage above 2.4V enables the IC while below 0.5V shuts down the IC. When the IC is in shutdown mode, all functions are disabled to reduce the supply current below 3µA.
6	CS	Power switch current sense input.
7	OUT	Boost converter power switch gate output. This pin outputs high voltage (5V) to drive the external nMOSFET.
8	VCC	5V linear regulator output pin. This pin should be bypassed to GND with a ceramic capacitor.
9	VIN	Supply input pin. A capacitor (typical 10µF) should be connected between the VIN and GND to keep the DC input voltage constant.
10	PWMA	Apply a high frequency PWM dimming signal to this pin to achieve PWM to DC dimming function.
11	COMP	Soft-start and control loop compensation.
12	PWMD	Apply a low frequency PWM signal to this pin to get directive PWM dimming function.
13	CH1	LED current sink 1. Leave the pin open directly if not used.
14	CH2	LED current sink 2. Leave the pin open directly if not used.
15	GND	Ground
16	CH3	LED current sink 3. Leave the pin open directly if not used.

Functional Block Diagram

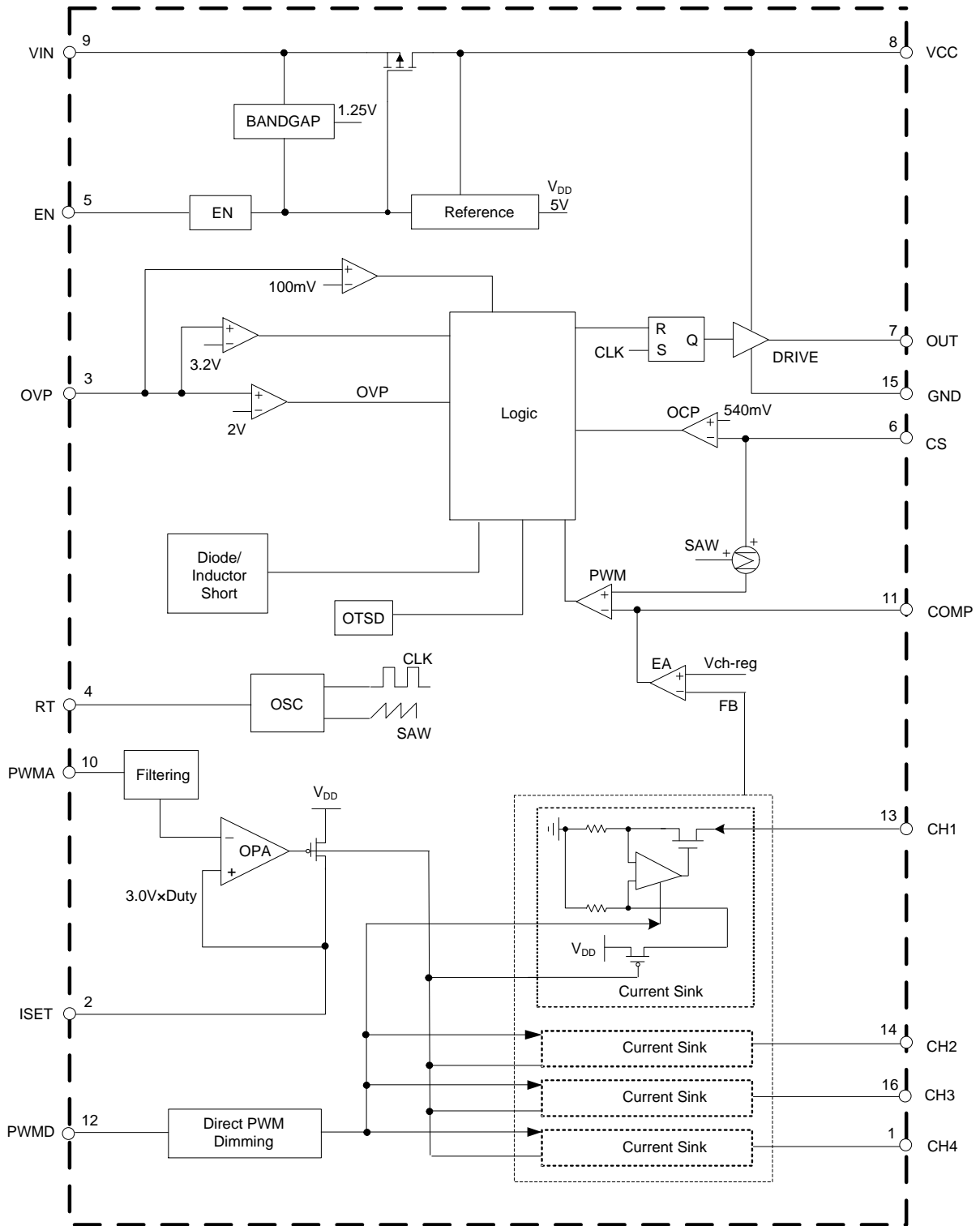

Absolute Maximum Ratings (@T_A = +25°C, unless otherwise specified.) (Notes 4, 5)

Symbol	Parameter	Rating	Unit
V _{IN}	Input Voltage	-0.3 to 60	V
V _{EN}	EN Pin Voltage	-0.3 to 7	V
V _{CC}	VCC Pin Voltage	-0.3 to 7	V
V _{CH}	CH1 to CH4 Pins Voltage	-0.3 to 80	V
V _{CS}	CS Pin Voltage	-0.3 to 60	V
V _{COMP}	COMP Pin Voltage	-0.3 to 7	V
V _{ISET}	ISET Pin Voltage	-0.3 to 7	V
V _{OUT}	OUT Pin Voltage	-0.3 to 7	V
V _{OVP}	OVP Pin Voltage	-0.3 to 60	V
V _{RT}	RT Pin Voltage	-0.3 to 7	V
V _{PWMA}	PWMA Pin Voltage	-0.3 to 7	V
V _{PWMD}	PWMD Pin Voltage	-0.3 to 7	V
V _{GND}	GND Pin Voltage	-0.3 to 0.3	V
θ _{JA}	Thermal Resistance (Junction to Ambient) (Note 6)	85	°C/W
θ _{JC}	Thermal Resistance (Junction to Case) (Note 6)	11	°C/W
T _J	Operating Junction Temperature	+150	°C
T _{STG}	Storage Temperature	-65 to +150	°C
T _{LEAD}	Lead Temperature (Soldering, 10sec)	+260	°C
—	ESD (Charge Device Model, CDM)	1000	V
—	ESD (Human Body Model, HBM)	4000	V

- Notes:
- Stresses greater than those listed under *Absolute Maximum Ratings* can cause permanent damage to the device. These are stress ratings only, and functional operation of the device at these or any other conditions beyond those indicated under *Recommended Operating Conditions* is not implied. Exposure to *Absolute Maximum Ratings* for extended periods can affect device reliability.
 - For better performance, the AL3069 should have high voltage pins CS and OVP. If CS or OVP pin is added to 16V, the IC will not smoke or burn.
 - Device mounted on 2" x 2" FR-4 substrate PCB, 2oz copper, with minimum recommended pad layout.

Recommended Operating Conditions

Symbol	Parameter	Min	Max	Unit
V _{IN}	Input Voltage	4.5	60	V
f _{SW}	Operating Switching Frequency	0.1	1	MHz
I _{CH}	LED Channel Current	20	400	mA
f _{PWMD}	Direct PWM Dimming Frequency	0.1	2	kHz
f _{PWMA}	PWM to Analog Dimming Frequency	5	100	kHz
T _A	Operating Ambient Temperature	-40	+85	°C

Electrical Characteristics (@T_A = +25°C, V_{IN} = 12V, V_{EN} = 5V, unless otherwise specified.)

Symbol	Parameter	Condition	Min	Typ	Max	Unit
Input Supply						
V _{IN}	Input Voltage	—	4.5	—	60	V
I _Q	Quiescent Current	No Switching	—	3	—	mA
I _{SHDN}	Shutdown Supply Current	V _{EN} = 0V	—	1	—	μA
V _{UVLO}	Undervoltage Lockout Voltage	V _{IN} Rising	3.7	4.0	4.3	V
V _{HYS}	UVLO Hysteresis	—	—	200	—	mV
V_{CC} Regulator						
V _{CC}	V _{CC} Voltage	V _{IN} ≥ 5.5V	—	5	—	V
		V _{IN} < 5.5V	—	V _{IN} -0.5	—	V
t _{RISE}	OUT Pin Rise Time	OUT Pin Load = 1nF	—	30	—	ns
t _{FALL}	OUT Pin Fall Time	OUT Pin Load = 1nF	—	30	—	ns
—	Load Regulation	Load = 0 to 30mA	—	5	—	mV/mA
—	Line Regulation	V _{IN} = 12V to 33V	—	0.3	—	mV/V
High Frequency Oscillator						
f _{OSC1}	Switch Frequency	R _T = 100kΩ	—	500	—	kHz
—	Switch Frequency Range	—	0.1	—	1	MHz
D _{MAX}	Max. Duty Cycle	R _T = 100kΩ	80	90	—	%
t _{ON_TIME}	Minimum On-time	—	—	100	—	ns
Enable Logic and Dimming Logic						
V _{EN_H}	EN High Voltage	—	2.4	—	—	V
V _{EN_L}	EN Low Voltage	—	—	—	0.5	V
V _{PWMA_H}	PWM Logic for External Dimming	—	2.5	—	—	V
V _{PWMA_L}		—	—	—	0.3	V
V _{PWMD_H}	PWM Logic for External Dimming	—	2.5	—	—	V
V _{PWMD_L}		—	—	—	0.3	V
Power Switch Drive						
V _{LIMIT}	Current Limit Threshold Voltage	—	480	540	600	mV
V _{LIMIT2}	D/L Short Threshold Voltage	—	720	800	880	mV
t _{LEB}	Current Sense LEB Time (Note 7)	—	80	100	150	ns
Compensation and Soft-Start (COMP Pin)						
I _{O_H}	Sourcing Current	V _{COMP} = 0.5V	—	120	—	μA
I _{O_L}	Sinking Current	V _{COMP} = 2V	—	120	—	μA

Electrical Characteristics (continued) (@T_A = +25°C, V_{IN} = 12V, V_{EN} = 5V, unless otherwise specified.)

Symbol	Parameter	Condition	Min	Typ	Max	Unit
Overvoltage Protection						
V _{OVP}	OVP Threshold Voltage	V _{OUT} Rising	1.9	2.0	2.1	V
V _{OVP_HYS}	OVP Hysteresis	—	—	200	—	mV
V _{OVP_SH}	Shutdown Under Abnormal Condition	—	3.0	3.2	3.4	V
Current Source						
I _{CH}	Regulation Current per Channel	R _{ISET} = 21.8kΩ	52.3	55	57.7	mA
I _{CH_MATCH}	LED Current Matching Between Each String (Note 8)	I _{CH} = 55mA Analog Dimming PWM Duty Cycle = 100%	—	0.5	1	%
I _{CH}	Regulation Current per Channel	Analog Dimming	4	5.5	7	mA
I _{CH_MATCH}	LED Current Matching Between Each String (Note 8)	PWM Duty Cycle = 10%	-0.1	1.5	5	%
V _{LED_REG}	Minimum LED Regulation Voltage	I _{CH} = 120mA	—	500	—	mV
I _{LED_LEAK}	CH1 to CH4 Leakage Current	V _{EN} = 0V, V _{LED} = 37V	—	0.1	1	μA
V _{LED_S}	LED Short Protection Threshold	—	8.0	8.7	9.5	V
Overtemperature Protection						
T _{OTSD}	Thermal Shutdown Temperature (Note 7)	—	+155	+160	+165	°C
T _{HYS}	Thermal Shutdown Temperature Hysteresis (Note 7)	—	—	+30	—	°C

Notes: 7. Guaranteed by Design.

$$8. I_{CH_MATCH} = \frac{I_{MAX} - I_{MIN}}{2 \times I_{AVG}} \times 100\%$$

Performance Characteristic (@ $T_A = +25^\circ\text{C}$, $V_{IN} = 12\text{V}$, $V_{EN} = 5\text{V}$, unless otherwise specified.)

VCC Voltage vs. VIN Pin Voltage

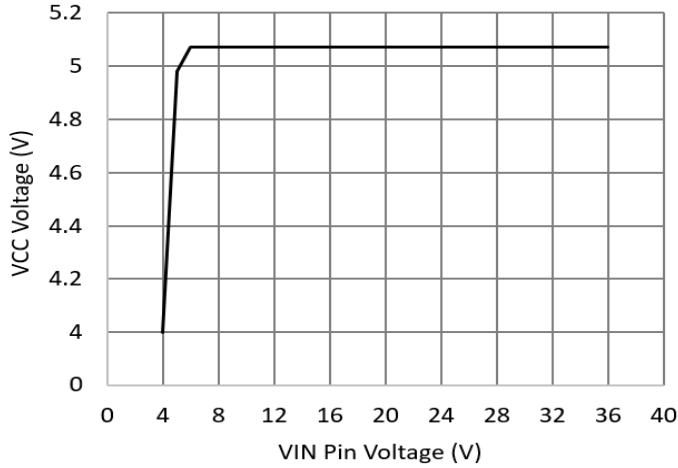

Switch Frequency vs. Ambient Temperature

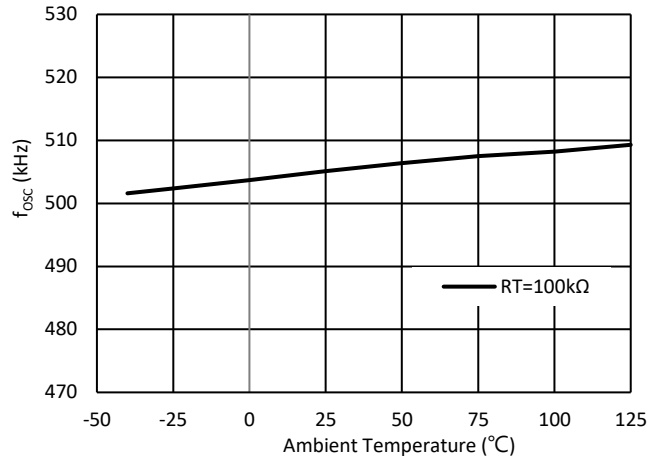

Quiescent Current vs. Ambient Temperature

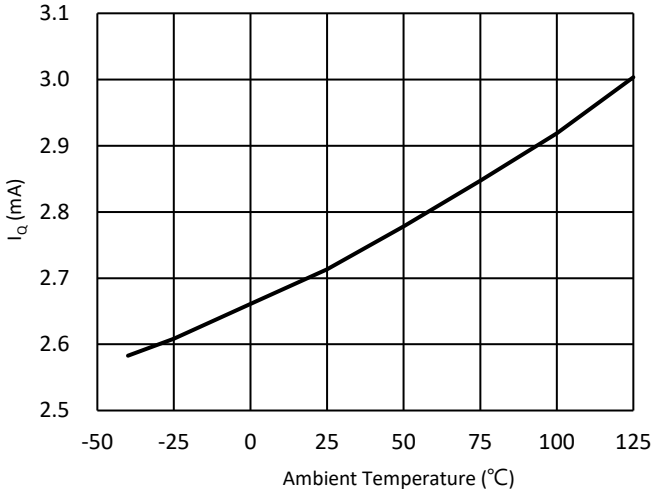

Shutdown Current vs. Ambient Temperature

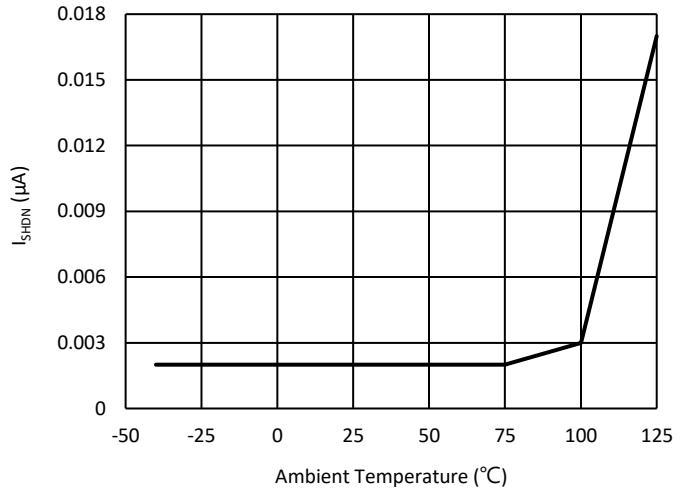

VuvLo vs. Ambient Temperature

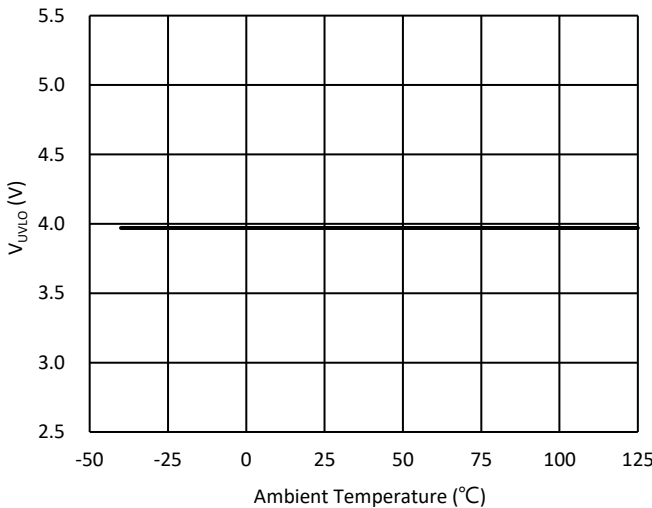

VovP vs. Ambient Temperature

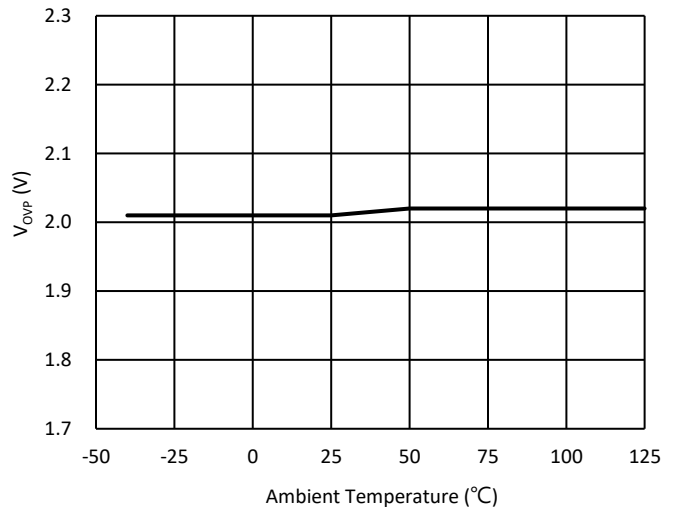

Performance Characteristic (continued) (@ $T_A = +25^\circ\text{C}$, $V_{IN} = 20\text{V}$, $V_{EN} = 5\text{V}$, unless otherwise specified.)

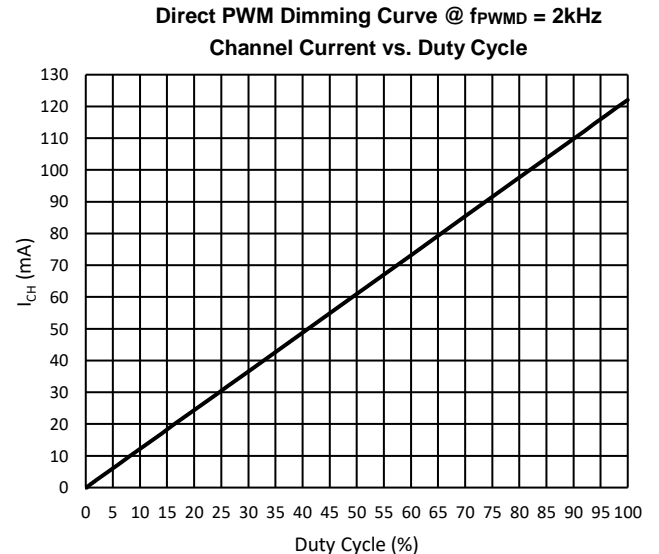
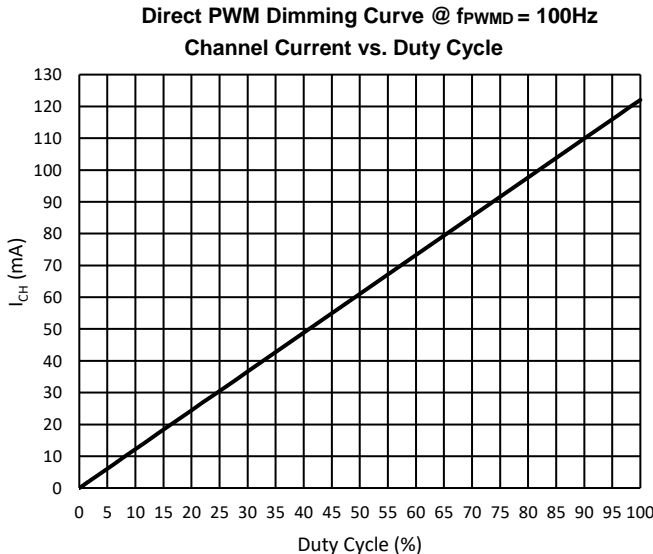
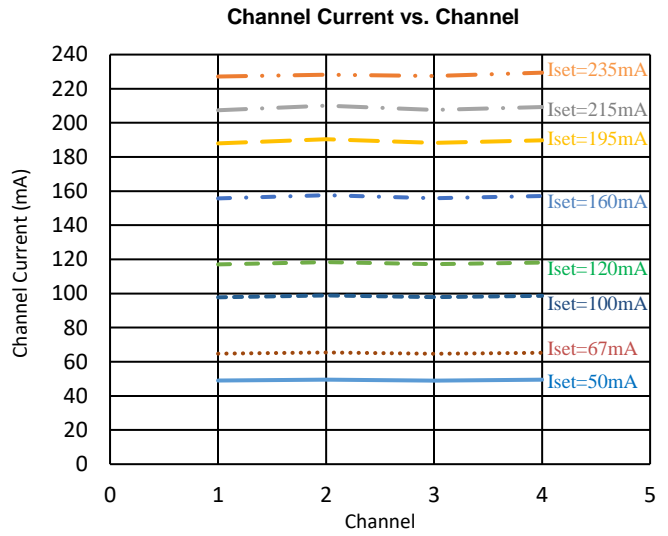
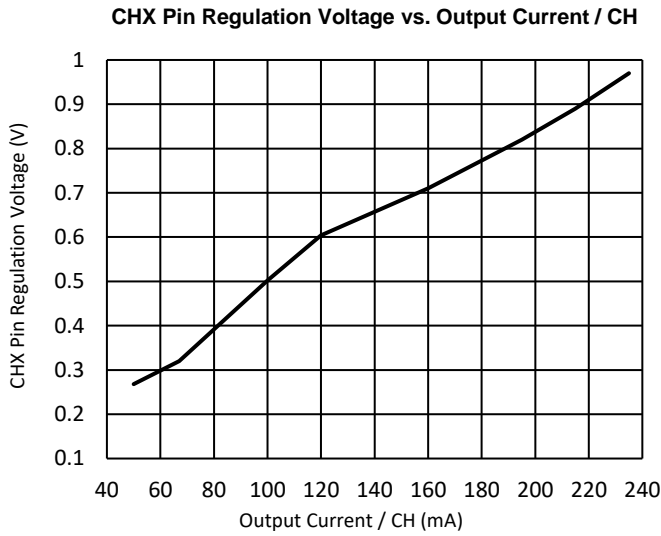
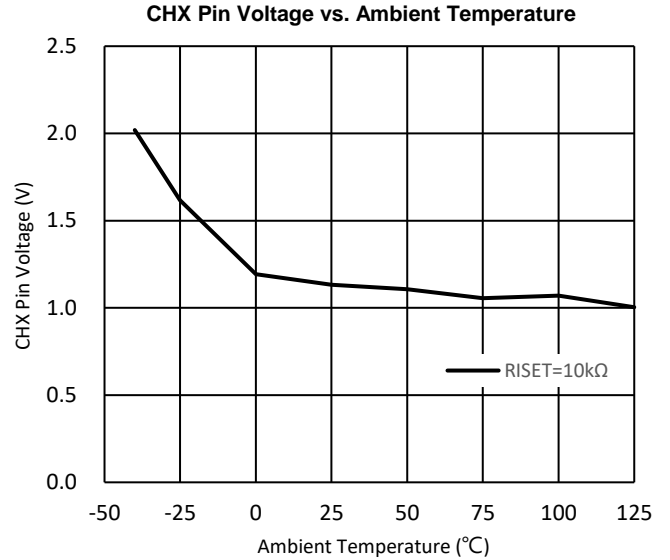
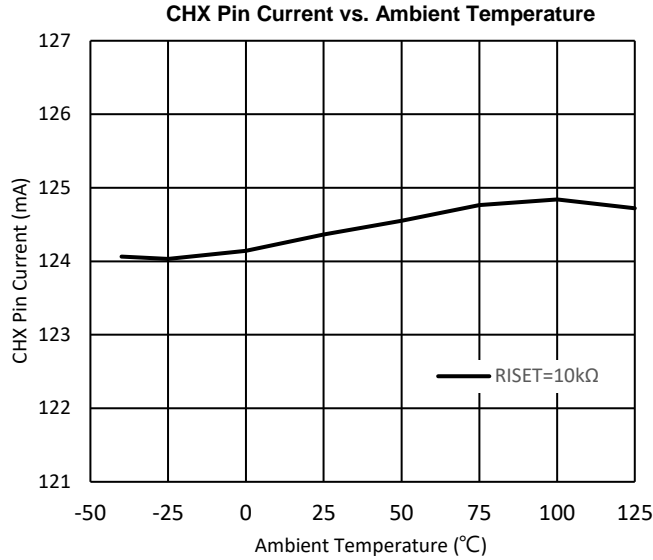

Performance Characteristic (continued) (@ $T_A = +25^\circ\text{C}$, $V_{IN} = 20\text{V}$, $V_{EN} = 5\text{V}$, unless otherwise specified.)

PWM to Analog Dimming Curve @ $f_{PWMA} = 5\text{kHz}$
Channel Current vs. Duty Cycle

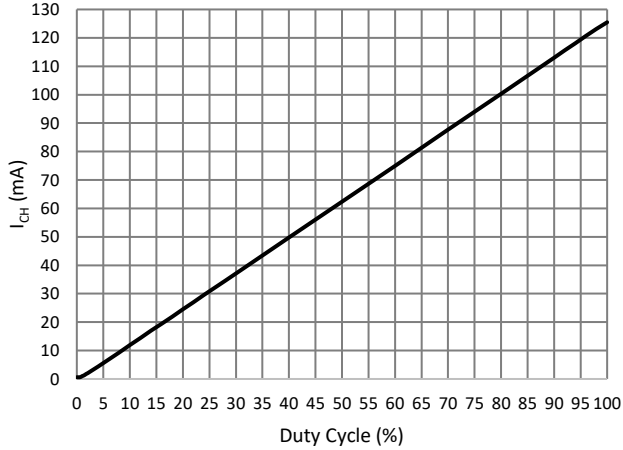

PWM to Analog Dimming Curve @ $f_{PWMA} = 100\text{kHz}$
Channel Current vs. Duty Cycle

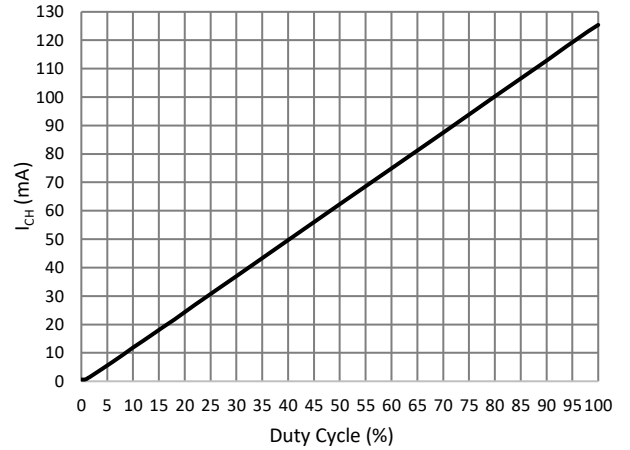

Steady State

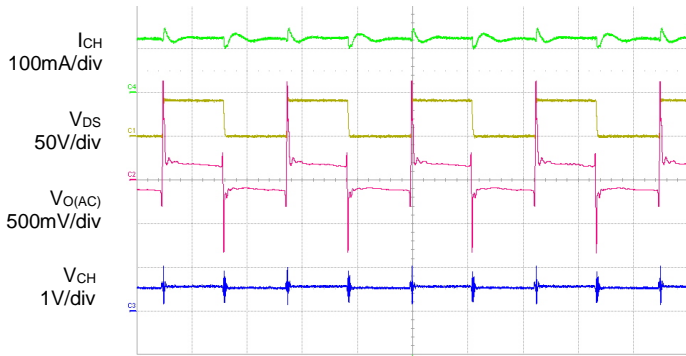

Time: 1 $\mu\text{s}/\text{div}$

System Startup

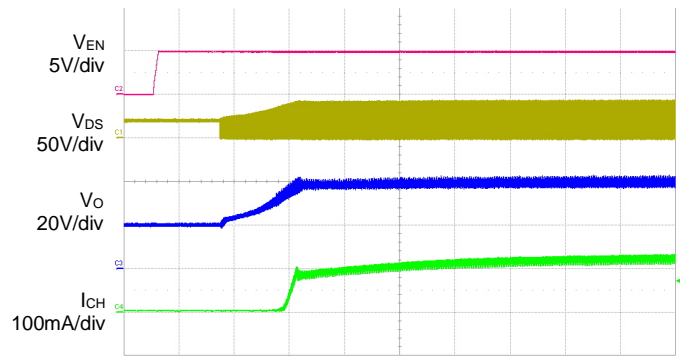

Time: 1ms/div

Direct PWM Dimming

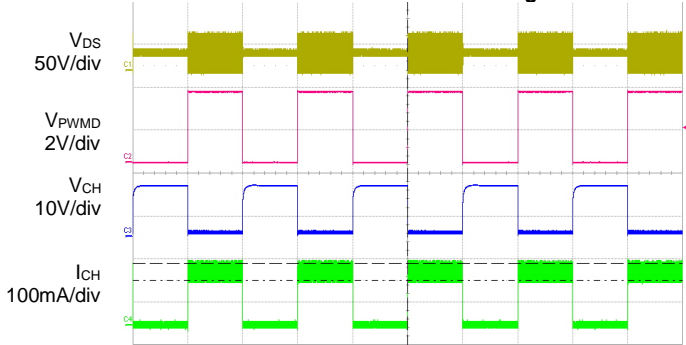

Time: 5ms/div

PWM to Analog Dimming

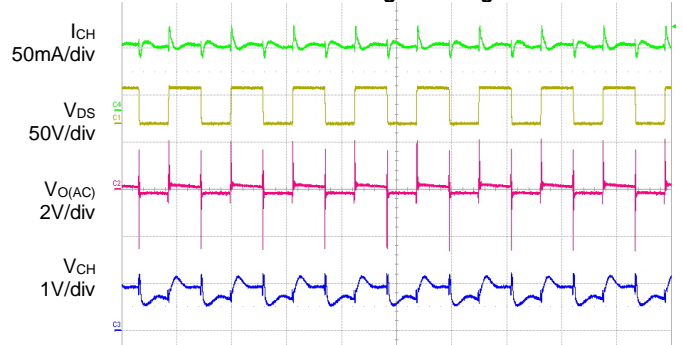

Time: 2 $\mu\text{s}/\text{div}$

Performance Characteristic (continued) (@ $T_A = +25^\circ\text{C}$, $V_{IN} = 20\text{V}$, $V_{EN} = 5\text{V}$, unless otherwise specified.)

LED Short Protection

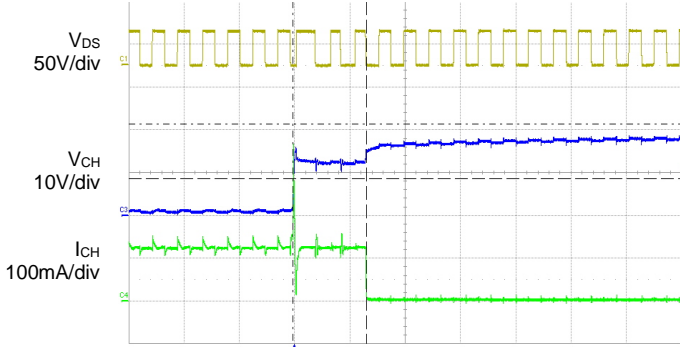

Time: 5 $\mu\text{s}/\text{div}$

LED Open Protection

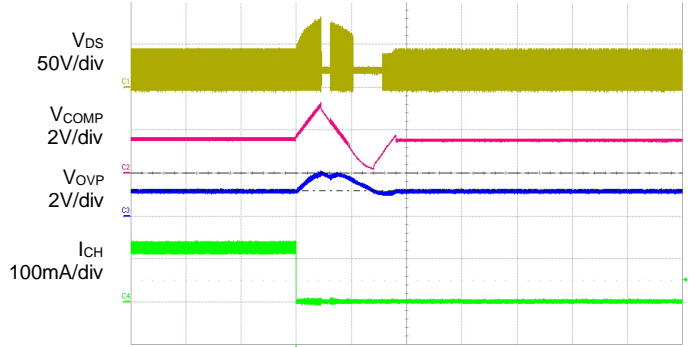

Time: 5ms/div

Schottky Short Protection

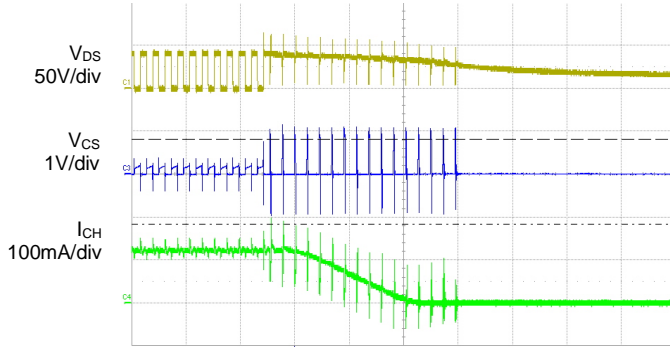

Time: 10 $\mu\text{s}/\text{div}$

Inductor Short Protection

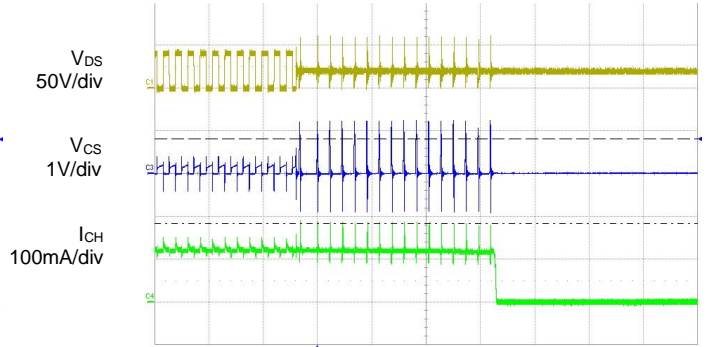

Time: 10 $\mu\text{s}/\text{div}$

OVP Short to GND Protection

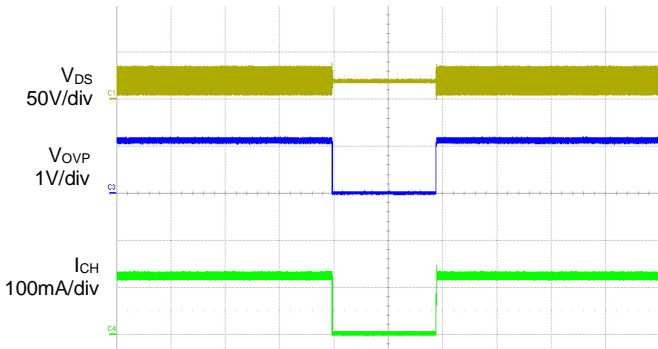

Time: 200ms/div

Overtemperature Protection

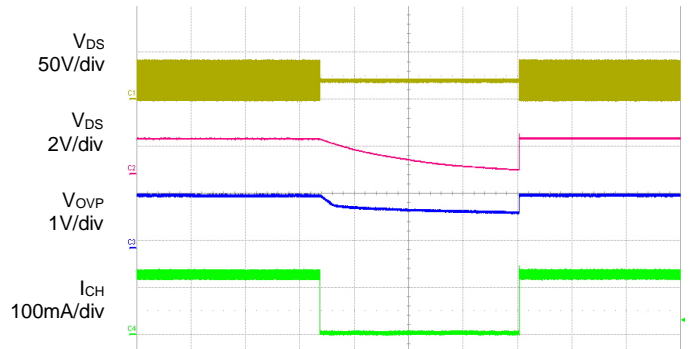

Time: 1s/div

Application Information

Enable

The AL3069 is enabled when the voltage at EN pin is greater than approximately 2.4V, and disabled when lower than 0.5V.

Frequency Selection

An external resistor R_T , placed between RT pin and GND, can be used to set the operating frequency. The operating frequency ranges from 100kHz to 1MHz. The high frequency operation optimizes the regulator for the smallest-sized component application, while low frequency operation can help to reduce switch loss. The approximate operating frequency can be expressed as below:

$$f_{OSC}[MHz] = \frac{52}{R_T[k\Omega]}$$

LED Current Setting

The maximum LED current per channel can be adjusted up to 400mA via ISET pin. When $\geq 400mA$ current is needed in application, two or more channels can be paralleled to provide larger drive current. A resistor R_{ISET} is connected between ISET pin and GND to set the reference current I_{SET} . The LED current can be expressed as below:

$$I_{LED}[mA] = \frac{1200}{R_{ISET}[k\Omega]}$$

Dimming Control

1) Direct PWM Dimming Control

Compared to analog dimming, PWM dimming offers superior dimming resolution and reduced LED color shift. The PWM signal is applied to the PWMD pin. The LED current of all enabled channels can be adjusted at the same time and the LED brightness can be adjusted from $1\% \times I_{CH_MAX}$ to $100\% \times I_{CH_MAX}$.

During the “high level” period of PWM signal, the LED is turned on, while during the “low level” period of the PWM signal, the LED is turned off and almost no current flows through the LED. Changing the average current through the LED can adjust the LED brightness.

The external PWM signal frequency applied to PWMD pin can be 100Hz or higher and the minimum duty PWM duty can be 1/10,000 at 100Hz dimming frequency.

2) PWM to Analog Dimming Control

The IC provides PWM to analog dimming function performed by tying a high frequency PWM signal on PWMA pin. The internal filter block smooths input 0% to 100% PWM signal to a 0.09 to 3VDC signal which modulates the LED current amplitude. To get better smoothing effect, PWM frequency should be higher than 5kHz.

1- to 3-Channel Recommended Connections

For applications using fewer than four LED strings, one option is to leave the unused channels open. However, LED open-circuit protection is triggered at each startup to disable the unused channels.

To avoid LED open-circuit protection at each startup, use the following recommended connections.

For applications using only one LED string, all four channels must be tied together, and the current setting for each channel is one quarter of the desired output current.

Application Information (continued)

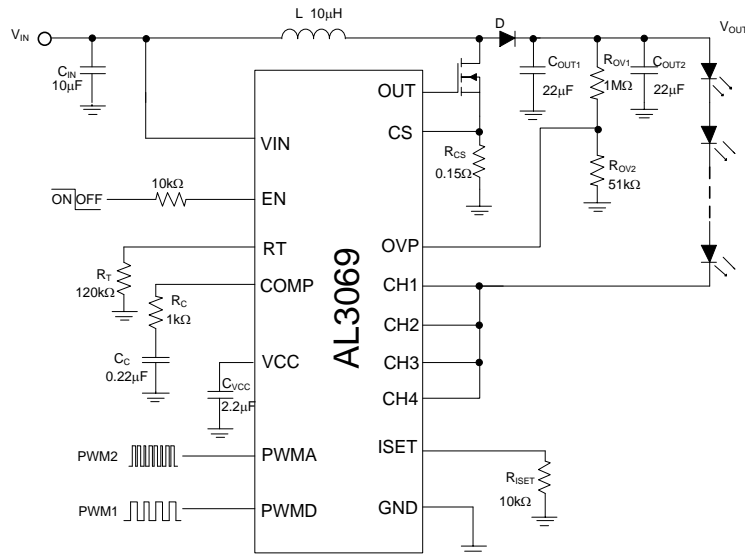

One Channel Recommended Connection

For applications using two LED strings, every two channels must be tied together (CH1 & CH2, CH3 & CH4), and the current setting for each channel is half of the desired output current of each LED string.

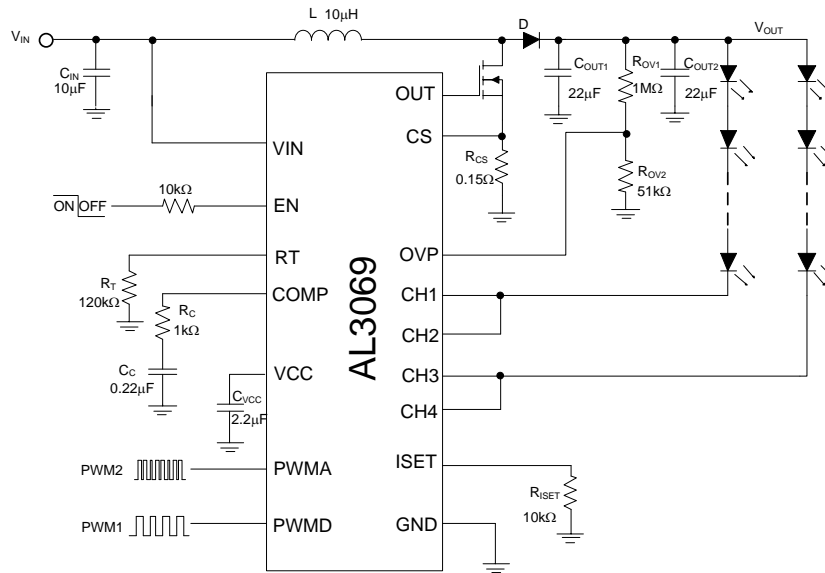

Two Channels Recommended Connection

For applications using three LED strings, the AL3069 provides design flexibility by disabling the fourth channel, CH4 opened. A resistor RT is required to be connected between RT pin and VCC pin instead of connecting between RT pin and GND pin. The three LED strings must be connected to CH1, CH2, and CH3 correspondingly.

Application Information (continued)

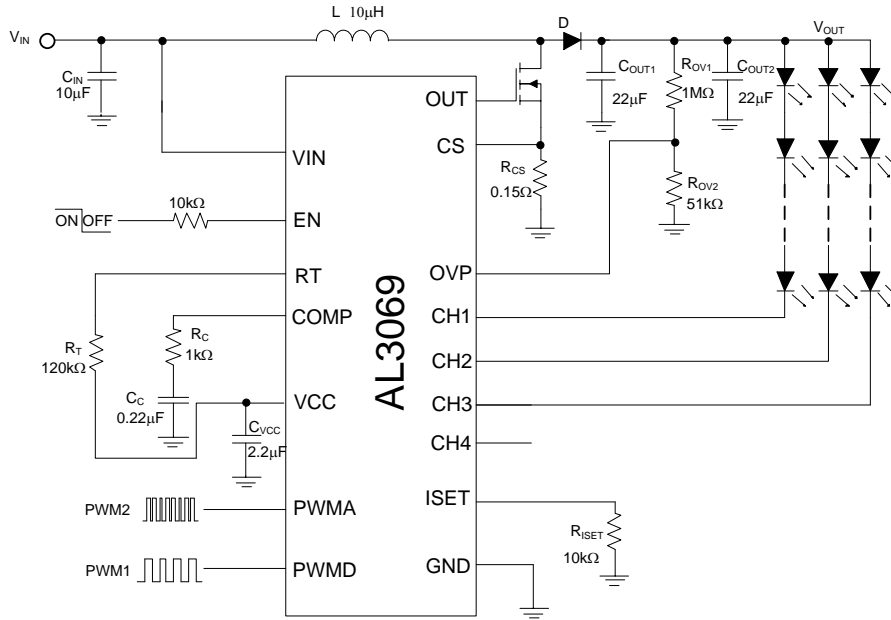

Three Channels Recommended Connection

Protection

1) Overvoltage Protection

The AL3069 integrates an OVP circuit. The OVP pin is connected to the center tap of voltage-divider (R_{OV1} and R_{OV2}) connected between high voltage output and GND.

If the voltage at OVP pin exceeds 2.0V, which may result from open loop or excessive output voltage, all the functions of the AL3069 will be disabled with output voltage falling. The OVP hysteresis is 200mV.

2) Overcurrent Protection

The AL3069 integrates an OCP circuit. The CS pin is connected to the voltage-sensor (R_{CS}) placed between the source of the MOSFET and GND. If the voltage at CS pin exceeds 0.54V, the MOSFET is turned off immediately and will not turn on until the next cycle begins.

3) LED Short-Circuit Protection

The AL3069 integrates an LED short-circuit protection circuit. If the voltage at any of the CH1 to CH4 pins exceeds a threshold of approximately 8.7V and 7 μ s delay time during normal operation, the corresponding channel is latched off. Toggle V_{IN} or EN to reset the latch. LED short detecting logic priority is lower than open LED and OVP logic. The LED short detecting is triggered when $0.1V < V_{LED_MIN}$ under dimming on mode, and disabled when LED open occurs until output voltage resumes to the regulated voltage.

4) LED Open-Circuit Protection

The AL3069 integrates an LED open-circuit protection circuit. When any LED string is open, V_{OUT} will boost up until the voltage at OVP pin reaches an approximate threshold of 2.0V. The IC will automatically ignore the open string whose corresponding pin voltage is less than 100mV and the remaining string will continue operation. If all the strings are open and the voltage at OVP pin reaches a threshold of 2.0V, the MOSFET drive gate will turn off and the IC will shut down and latch.

5) V_{OUT} Short/Open Schottky Diode Protection

The AL3069 monitors the OVP pin. If the OVP pin voltage is less than 0.1V, MOSFET drive output will turn off. This protects the converter if the output Schottky diode is open or V_{OUT} is shorted to ground.

Application Information (continued)

6) Undervoltage Lockout

The AL3069 provides an undervoltage lockout circuit to prevent it from undefined status when it starts up. The UVLO circuit shuts down the device when Vcc drops below 3.8V. The UVLO circuit has 200mV hysteresis, which means the device starts up again when Vcc rises to 4.0V.

7) Overtemperature Protection

The AL3069 features overtemperature protection. If the junction temperature exceeds approximately +160°C, the IC will shut down until the junction temperature is less than approximately +140°C. When the IC is released from overtemperature shutdown, it will start a soft-start process.

8) Schottky Diode/Inductor Short-Circuit Protection

The AL3069 features Schottky diode/inductor short-circuit protection circuit. When CS pin voltage exceeds 0.8V for greater than 16 switching clocks, the IC will latch off. The voltage of CS pin is monitored after a short delay of tLEB.

9) Shutdown under Abnormal Condition

The AL3069 features shutdown under abnormal condition protection circuit. When the OVP pin voltage exceeds 3.2V, the IC will latch off. Toggle EN pin to restart the IC. This feature can be used to shut down the IC under any defined abnormal condition.

Ordering Information

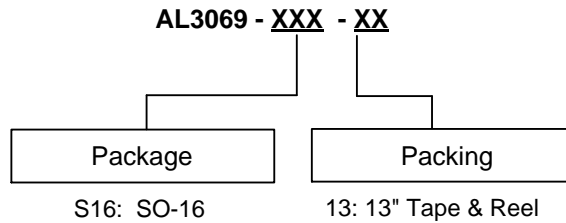

Part Number	Part Number Suffix	Package Code	Package	Packing	
				Qty.	Carrier
AL3069S16-13	-13	S16	SO-16	2500	Tape & Reel

Marking Information

Package Type: SO-16

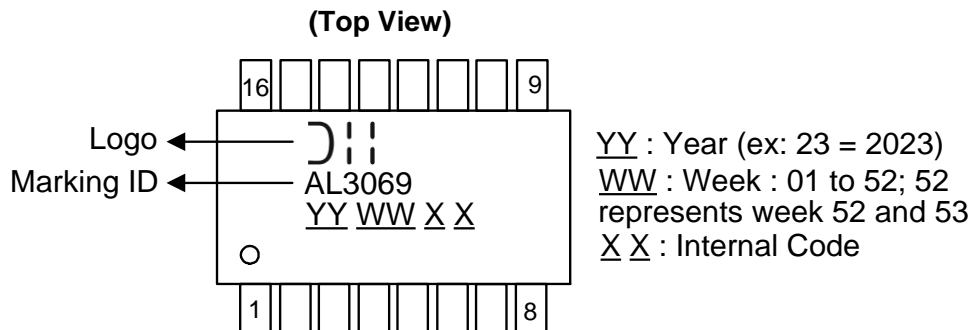

Package Outline Dimensions

Please see <http://www.diodes.com/package-outlines.html> for the latest version.

SO-16

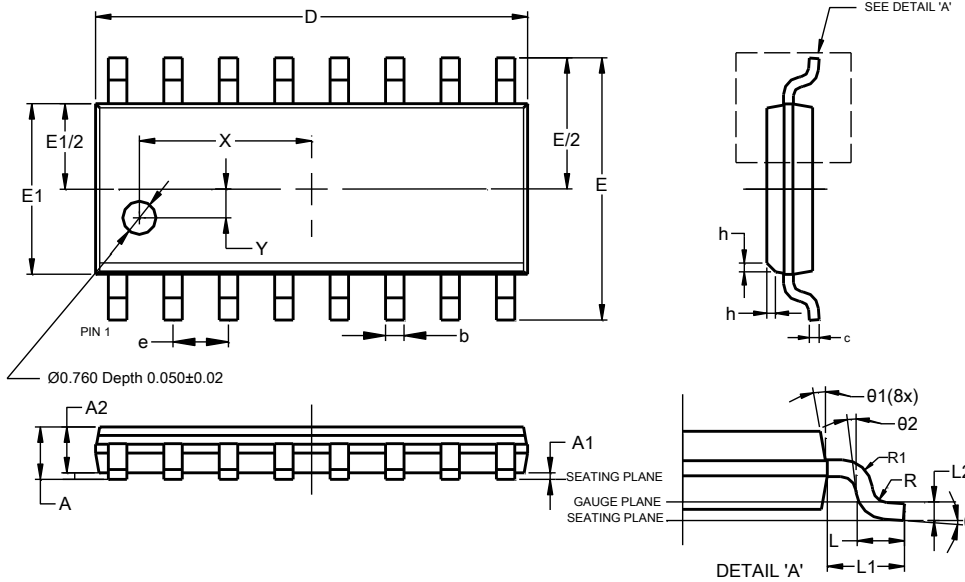

SO-16			
Dim	Min	Max	Typ
A	--	1.260	--
A1	0.10	0.23	--
A2	1.02	--	--
b	0.31	0.51	--
c	0.10	0.25	--
D	9.80	10.00	--
E	5.90	6.10	--
E1	3.80	4.00	--
e	1.27 BSC		
h	0.15	0.25	0.20
L	0.40	1.27	--
L1	1.04 REF		
L2	0.25 BSC		
R	0.07	--	--
R1	0.07	--	--
X	3.945 REF		
Y	0.661 REF		
θ	0°	8°	--
θ_1	5°	15°	--
θ_2	0°	--	--
All Dimensions in mm			

Suggested Pad Layout

Please see <http://www.diodes.com/package-outlines.html> for the latest version.

SO-16

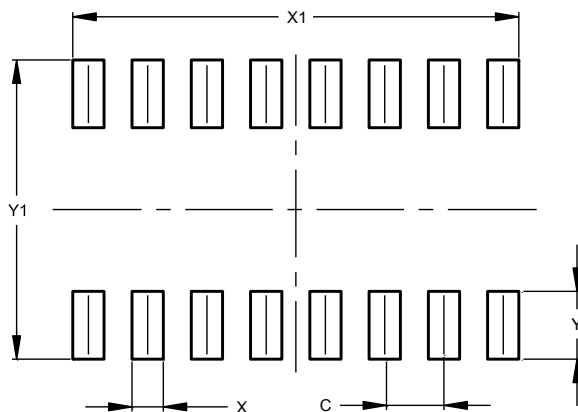

Dimensions	Value (in mm)
C	1.270
X	0.670
X1	9.560
Y	1.450
Y1	6.400

Mechanical Data

- Moisture Sensitivity: Level 1 per JESD22-A113
- Terminals: Finish-Matte Tin plated Leads, Solderable per M2003 JESD22-B102 **e3**
- Weight: 0.1298 grams (Approximate)