

## Description

The AL5817 is an 8-terminal adjustable linear LED driver-controller offering excellent temperature stability and output current capability. It works with a wide input voltage range from 4.5V to 60V. With an external LED driving power device, its internal power dissipation is minimized compared with traditional linear LED drivers. This makes it ideal for medium to high current LED circuits.

The AL5817 has internal output drive capability up to 15mA, which enables it to drive external Bipolar transistors or MOSFETs. It also provides the capability to drive longer LED chains with low drop out voltage and multiple LED channels.

The VSET pin is used to directly set output current feedback level. Using a resistor divider between REF pin and VSET pin, the output current can be set. Additionally, the use of an NTC resistor allows the creation of an accurate and configurable thermal fold-back behavior.

The AL5817 provides an LED-open detection feature through its VFAULT pin. If VFAULT is brought lower than 2.5V (by any one of the multiple LED channels going open) the AL5817's output will go low turning off the external transistors. The device will recover when the open condition is removed. This ability of VFAULT to turn off the external transistors also allows PWM dimming of the LED current by adding PWM control signal on VFAULT pin.

An enable pin ENB is available to externally turn on and off the LEDs.

The AL5817 is available in the thermally enhanced MSOP-8EP package.

## Features

- Wide Input Voltage Range from 4.5V to 60V
- Configurable LED Current Setting
- 4% Reference Voltage Tolerance
- Low Temperature Drift
- 15mA Output Drive Capability for MOSFET or Bipolar Transistor
- LED Open Protection Detected by VFAULT Pin
- LED Thermal Fold-back Configured by VSET
- Over Temperature Protection (OTP)
- Input Under Voltage Lock-Out
- PWM Dimming Realized Through VFAULT Pin or ENB Pin
- **Totally Lead-Free & Fully RoHS Compliant (Notes 1 & 2)**
- **Halogen and Antimony Free. "Green" Device (Note 3)**

- Notes:
1. No purposely added lead. Fully EU Directive 2002/95/EC (RoHS), 2011/65/EU (RoHS 2) & 2015/863/EU (RoHS 3) compliant.
  2. See <https://www.diodes.com/quality/lead-free/> for more information about Diodes Incorporated's definitions of Halogen- and Antimony-free, "Green" and Lead-free.
  3. Halogen- and antimony-free "green" products are defined as those which contain <900ppm bromine, <900ppm chlorine (<1500ppm total Br + Cl) and <1000ppm antimony compounds.

## Pin Assignments

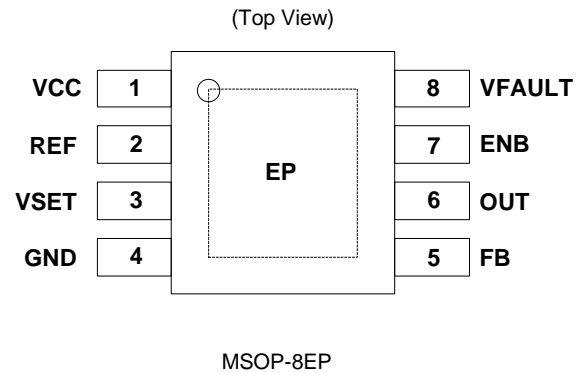

## Applications

- Automotive Rear Combination Light
- LED Signs
- Instrumentation Illumination
- Refrigerator Lights

**Typical Application Circuit**

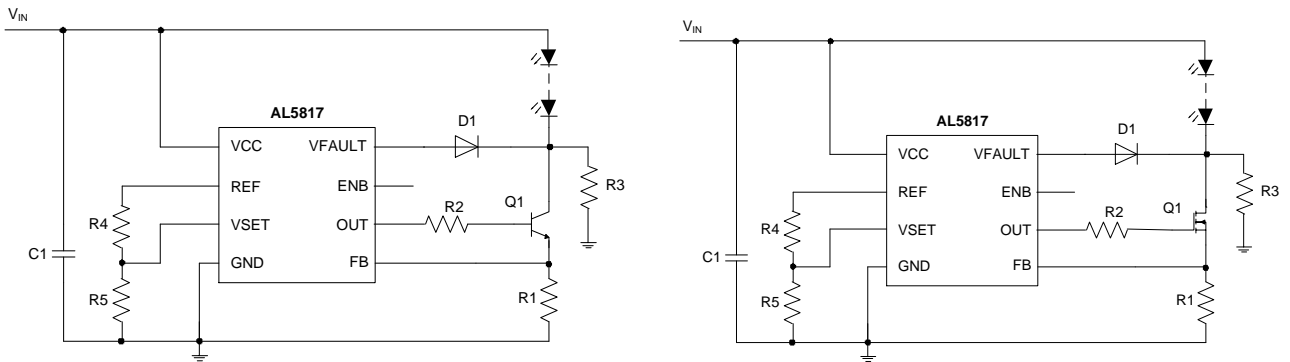

Figure 1

**Pin Descriptions**

Pin Number	Pin Name	Function
1	VCC	Supply input
2	REF	Internal reference voltage. The maximum recommended output current is 50µA and the maximum recommended capacitor connected from this pin to GND is less than 100pF. A potential divider from REF to VSET can be used to accurately set the output LED current.
3	VSET	LED current setting threshold. The voltage on VSET sets the reference voltage for the FB pin. This pin is pulled down internally if left floating. The capacitance if needed between VSET and GND is recommended to be less than 1nF.
4	GND	Ground
5	FB	Feedback input. When control loop is operating in linear mode the FB pin will be regulated to the level set by VSET. This pin is pulled up internally if left floating. A capacitor may be added between FB and GND to improve noise rejection. Value needs to be limited 100pF or less.
6	OUT	Driving output
7	ENB	Chip Enable An input voltage >2V disables the device and external transistor drive. This pin can be used for low frequency PWM dimming of the LED current.
8	VFAULT	Input for LED-open detection. When LED-open detection function is active, if VFAULT is brought lower than approximately 2.5V the device output will be turned off and will auto-retry driving the output to see if the fault still exists. A PWM dimming function will be realized by adding an open collector/drain signal on this pin.
EP	EP	Exposed Pad (bottom). Recommended to be connected to a large-area contiguous copper GND plane for effective thermal dissipation. Do not use as the IC's only electrical GND connection.

**Functional Block Diagram**

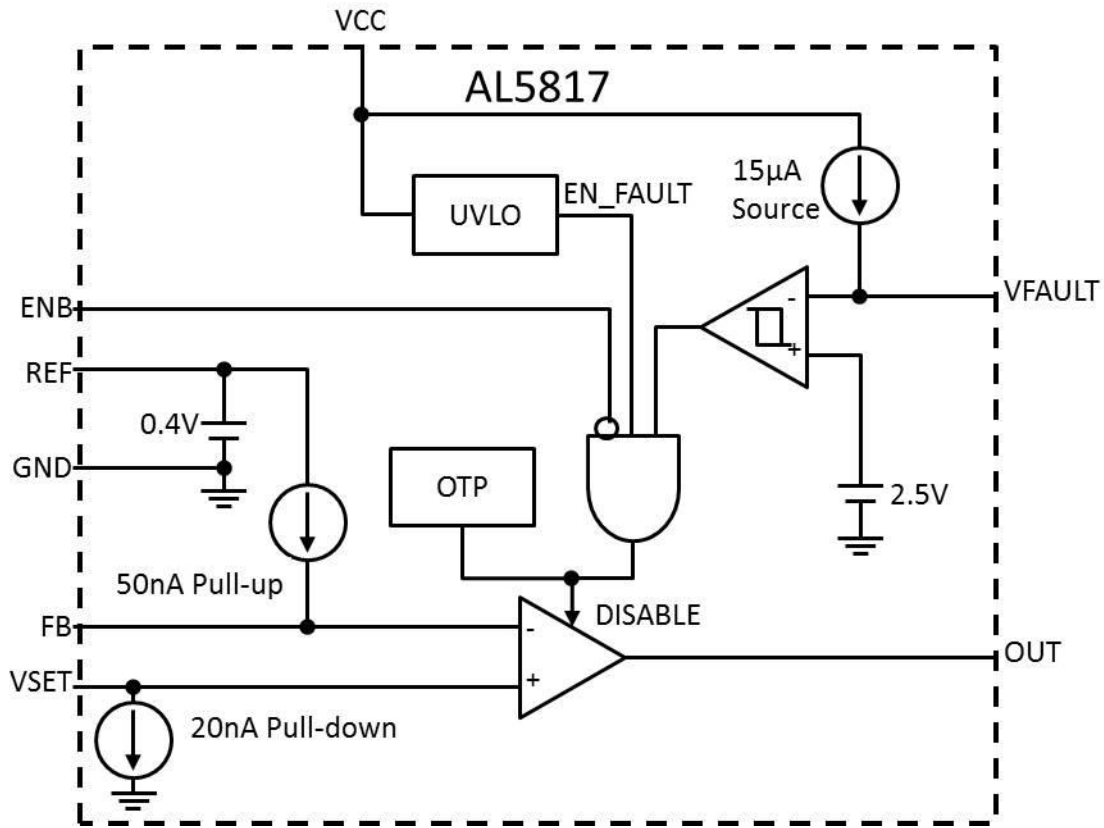

Figure 2

**Absolute Maximum Ratings** (Note 4)

Symbol	Parameter	Rating	Unit
$V_{VCC}$	Supply Voltage Relative to GND	-0.3 to 65	V
$I_{VCC}$	IC Supply Current	18	mA
$V_{VFAULT}$	Input Voltage Relative to GND	-0.3 to $V_{CC}$	V
$V_{REF}, V_{VSET}, V_{ENB}, V_{OUT}, V_{FB}$	Input Voltage of REF, VSET, ENB, OUT, FB Relative to GND	-0.3 to 6	V
$T_J$	Operating Junction Temperature	-40 to +150	°C
$T_{ST}$	Storage Temperature	-55 to +150	°C

Note: 4. Stresses greater than those listed under "Absolute Maximum Ratings" may cause permanent damage to the device. These are stress ratings only, and functional operation of the device at these or any other conditions beyond those indicated under "Recommended Operating Conditions" is not implied. Exposure to Absolute Maximum Ratings for extended periods may affect device reliability.

NEW PRODUCT

## ESD Ratings

Symbol	Parameter	Rating	Unit
V <sub>ESD</sub>	Human-Body Model (HBM)	2000	V
	Charged-Device Model (CDM)	1000	

## Recommended Operating Conditions

Symbol	Parameter	Min	Max	Unit
V <sub>VCC</sub>	Supply Voltage Range Relative to GND Pin	4.5	60	V
V <sub>OUT</sub>	OUT Voltage Range	0	4	V
I <sub>OUT</sub>	OUT Pin Current	0	15	mA
V <sub>VSET</sub>	VSET Pin Operating Input Voltage Range	0	0.6	V
T <sub>J</sub>	Operating Junction Temperature Range	-40	+125	°C
T <sub>A</sub>	Operating Ambient Temperature	-40	+105	°C

## Thermal Information (Notes 5 and 6)

Symbol	Parameter	Rating	Unit
θ <sub>JA</sub>	Junction-To-Ambient Thermal Resistance	90	°C/W
θ <sub>JC</sub>	Junction-To-Case (Top) Thermal Resistance	39	°C/W

- Note:
5. Dominant conduction path via exposed pad.
  6. Test condition for MSOP-8EP: Device mounted on FR-4 PCB (51mm x 51mm 2oz copper, minimum recommended pad layout on top layer and thermal vias to bottom layer ground plane. For better thermal performance, larger copper pad for heat-sink is needed.

**Electrical Characteristics** ( $V_{CC} = 12V$  and  $T_A = +25^\circ C$ , unless otherwise specified.)

Symbol	Parameter	Conditions	Min	Typ	Max	Unit
<b>Power Supply</b>						
$V_{UVLO}$	Under-Voltage Lockout Voltage	$V_{IN}$ Rising	-	4.2	4.4	V
		$V_{IN}$ Falling	3.6	3.85	-	
$I_{CC}$	Supply Current	$V_{CC} = 4.5V$ to $60V$ , $I_{OUT} = 10mA$	-	10.25	11	mA
$I_Q$	No Load Quiescent Current	$V_{CC} = 4.5V$ to $60V$ , $I_{OUT} = 0$	-	0.25	1	mA
$I_{SHDN}$	Shutdown Supply Current	$V_{ENB} > 2.5V$ , $V_{CC} = 4.5V$ to $60V$	-	3	20	$\mu A$
$V_{ENB\_TH}$	ENB Threshold Voltage	-	0.4	1.3	2	V
$R_{EN}$	ENB Pin Internal Pull-down Resistor	-	1.3	2	2.7	M $\Omega$
<b>Reference and Feedback loop</b>						
$V_{REF}$	Reference Voltage	$V_{CC} = 4.5V$ to $60V$ , $I_{OUT} = 0$ , $I_{REF} = 20\mu A$	0.384	0.4	0.416	V
$V_{REF\_LINE}$	Reference Voltage Line Regulation	$V_{CC} = 4.5V$ to $19V$	-	0.2	3	mV
$V_{REF\_LOAD}$	Reference Voltage Load Regulation	$I_{REF} = 0$ to $-50\mu A$	-	1.4	6	mV
$I_{FB}$	FB Input Bias Current	$V_{FB} = 0.2V$	-200	-125	-80	nA
$I_{SET}$	SET Input Bias Current	$V_{SET} = 0.6V$	-	25	45	nA
$V_{OFFSET}$	VSET to $V_{FB}$ Offset	$V_{SET} = 0.2V$ , $V_{FB} = V_{OUT}$	-	-	7	mV
<b>Fault Detection and Protection</b>						
$I_{VFAULT}$	Source Current from VFAULT Pin	$V_{CC} = 4.5V$ to $60V$	-20	-15	-10	$\mu A$
$V_{VFAULT}$	VFAULT Pin Threshold Voltage	$V_{CC} = 4.5V$ to $60V$ , $V_{VFAULT}$ Falling	2.37	2.5	2.63	V
$V_{VFAULT\_HYS}$	$V_{VFAULT}$ Hysteresis	-	-	100	-	mV
$t_{VF\_OUTR}$	VFAULT to OUT Rising Delay	-	-	2	-	$\mu s$
$t_{VF\_OUTF}$	VFAULT to OUT Falling Delay	-	-	1	-	
$T_{SHDN}$	Thermal Shutdown	-	-	+160	-	$^\circ C$
$T_{HYS}$	Thermal Shutdown Hysteresis	-	-	+30	-	
<b>Output Driver Error Amplifier</b>						
$I_{OUTSOURCE}$	Maximum Source Current $V_{SET} - V_{FB} = 10mV$	$V_{OUT} = 0V$ , $V_{CC} = 4.5V$ to $60V$	-	-	-15	mA
		$V_{OUT} = 1V$ , $V_{CC} = 4.5V$ to $60V$	-	-	-15	
		$V_{OUT} = 2V$ , $V_{CC} = 4.5V$ to $60V$	-	-	-11	
		$V_{OUT} = 4V$ , $V_{CC} = 6.0V$ to $60V$	-	-	-5	
$I_{OUTSINK}$	Maximum Sink Current	$V_{CC} = 12V$ , $V_{OUT} = 4V$ , $V_{VFAULT} > 2.7V$ , $V_{SET} - V_{FB} = -50mV$	20	-	-	$\mu A$
		$V_{CC} = 12V$ , $V_{OUT} = 4V$ , $V_{SET} - V_{FB} = -50mV$ , $V_{VFAULT} < 2.3V$	0.3	-	-	mA
$G_m$	Trans-Conductance of Error Amplifier	$V_{SET} - V_{FB} = 5mV$ , Sourcing Current	-	4	-	A/V
$BW$	Bandwidth	-	-	50	-	kHz
$V_{OUTMAX}$	Maximum Output Voltage	$V_{CC} \geq 6V$ , $I_{OUT} = -1mA$	4	-	-	V
$V_{OUTMIN}$	Minimum Output Voltage	$V_{CC} = 12V$ , $I_{OUT} = 0.1mA$ , $V_{FB} = 250mV$	-	-	300	mV
$t_{ON}$	Turn On Delay Time	ENB Active Low	-	85	-	$\mu s$
$t_{OFF}$	Turn Off Delay Time	ENB Active High	-	1	-	$\mu s$

**Performance Characteristics** ( $V_{CC} = 12V$ ,  $T_A = +25^\circ C$ , unless otherwise specified.)

NEW PRODUCT

**Supply Current vs. Temperature**

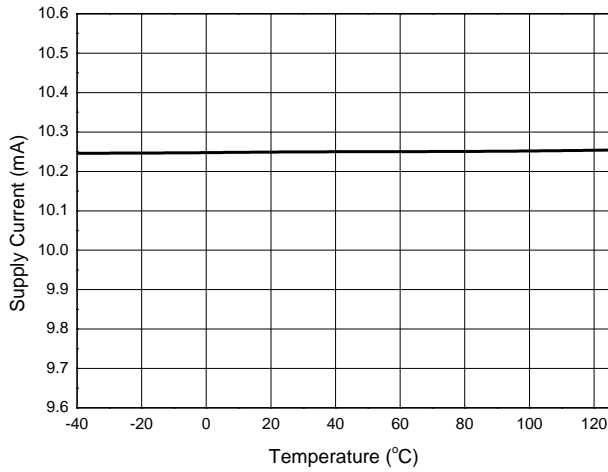

**Quiescent Current vs. Temperature**

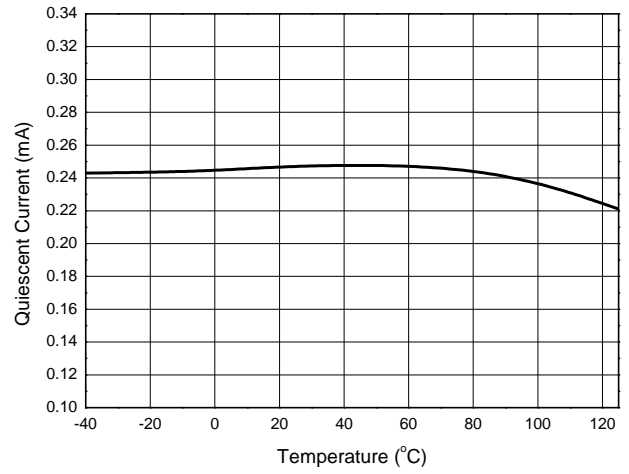

**$V_{UVLO}$  vs. Temperature**

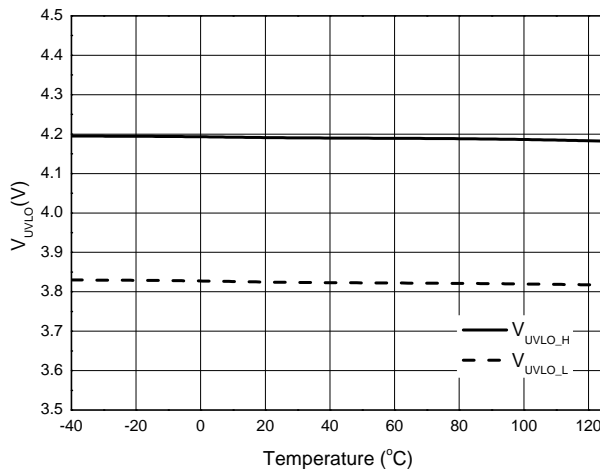

**Shutdown Current vs. Temperature**

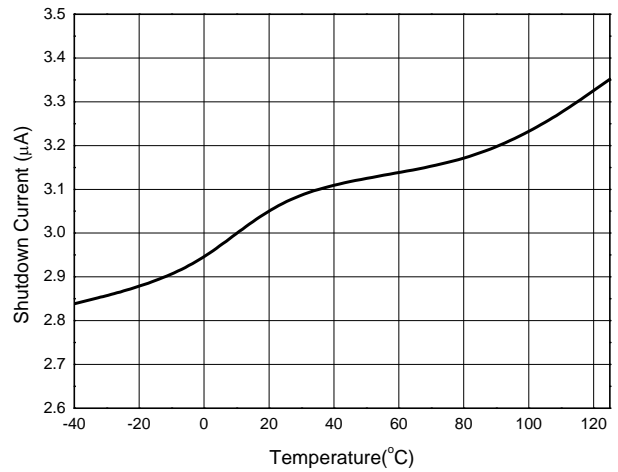

**$V_{REF}$  vs. Temperature**

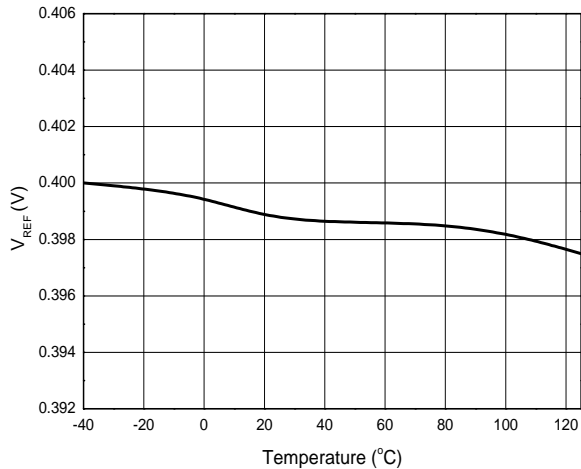

**$I_{VFAULT}$  vs. Temperature**

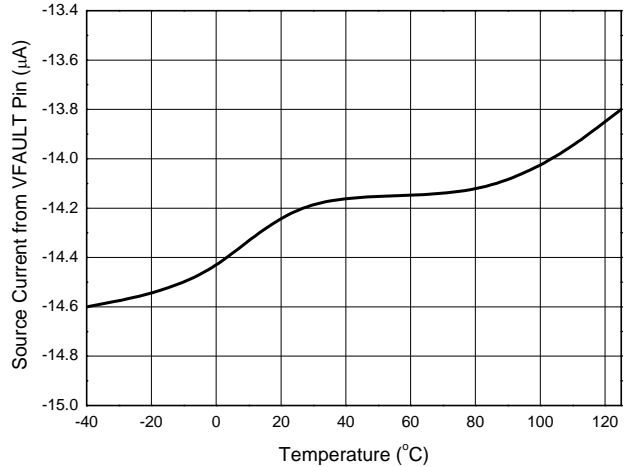

**Typical Performance Characteristics** (Cont.) ( $V_{CC} = 12V$ ,  $T_A = +25^\circ C$ , unless otherwise specified.)

**$V_{FAULT}$  vs. Temperature**

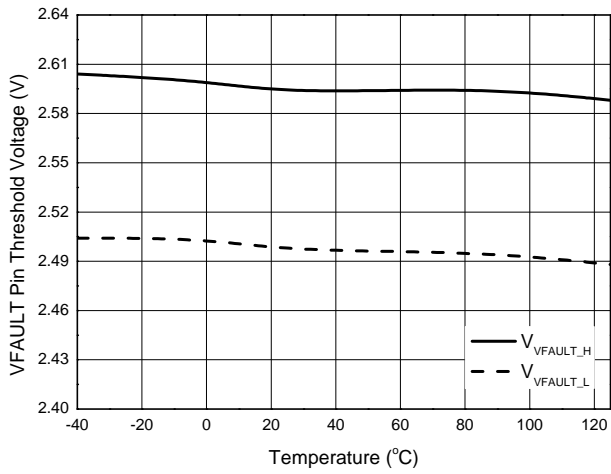

**Source Current vs. Temperature**

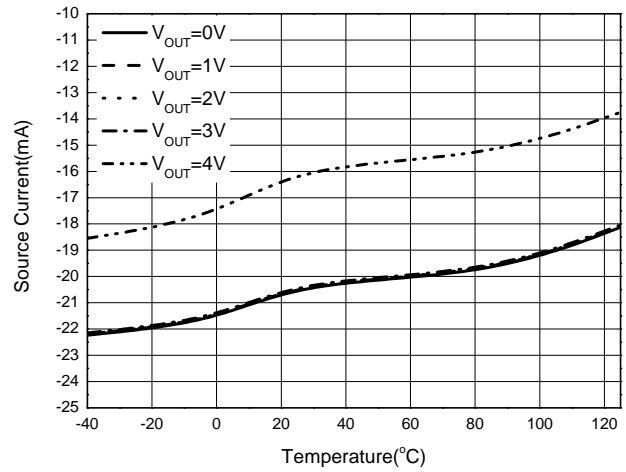

NEW PRODUCT

## Application Information

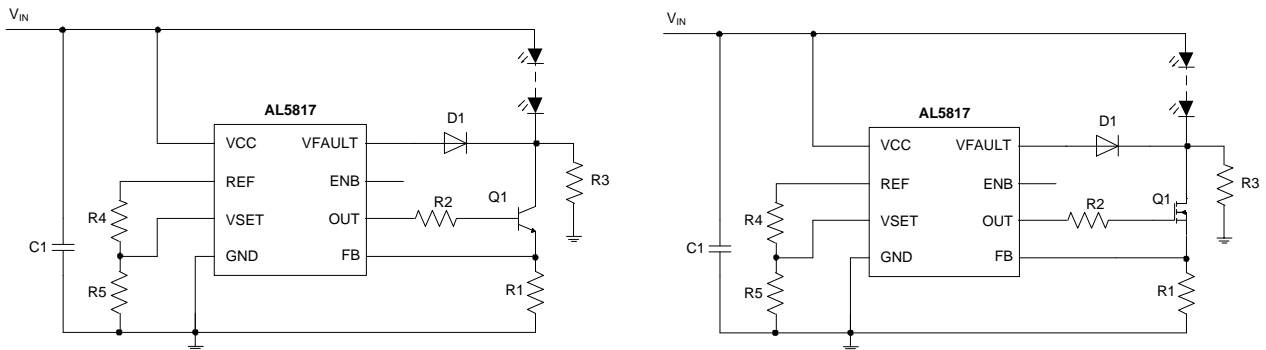

**Figure 3. Typical Application**

### Output Drive

Figure 3 shows the typical output drive configuration. The feedback loop regulates the current through the external LEDs. The voltage across the external sense resistor ( $R_1$ ) is fed to the FB pin for sensing. When the voltage exceeds  $V_{SET}$  voltage the OUT goes lower, decreasing the drive to the external transistor.

The output current can be set as following:

$$I_{LED} = \frac{V_{VSET}}{R_1} \quad (1)$$

Where  $I_{LED}$  is the desired LED current,  $V_{VSET}$  is determined by  $R_4$  and  $R_5$  resistor divider and  $R_1$  is the sense resistor.

The power in the sense resistor is calculated as:

$$Power = V_{VSET} * I_{LED}$$

Where  $V_{VSET} = V_{SET}$  voltage and  $I_{LED}$  is the desired LED string current. For most cases, a standard 1/4W resistor will work. Similarly, the external transistor's power dissipation also must be considered to prevent thermal damage to the transistor, which can further damage the LED controller IC.

### Power Consideration of the NMOS or BJT Device

The power rating of the transistor (either BJT or NMOS) used in the typical application circuit is important. A correctly mounted transistor used in a typical application can dissipate power of up to 2W. To calculate power dissipation, first calculate the voltage drop across the transistor as follows:

$$V_{DS} = V_{CC} - V_{LED} - V_{VSET}$$

Then calculate the power dissipation requirement:

$$Power = V_{DS} * I_{LED}$$

If power dissipation is higher than the transistor package and layout can dissipate then a higher power dissipation transistor must be selected and/or use a better PCB layout.

### Multiple LED Strings in Parallel

AL5817 can drive more than one channel of LED strings. As shown in Figure 4, the sense voltage of two channels' (or more) output current can be implemented by connecting the voltage of one sense resistor to the FB pin.

By utilizing the same type transistors, sense resistors and series base resistors, the currents in all channels will match.



**Application Information (Cont.)**

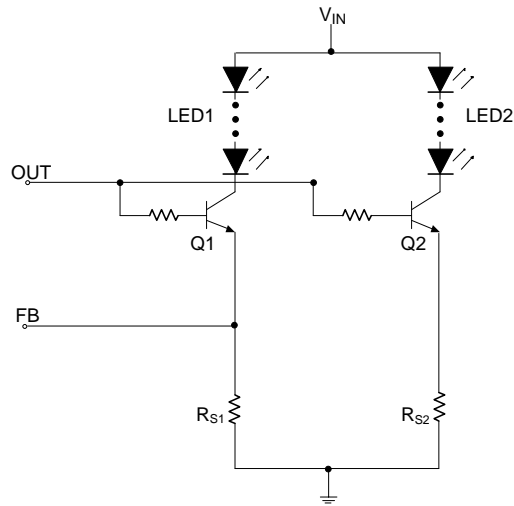

**Figure 4. Two LED Strings in Parallel**

The output current can be set as following:  $I_{LED1} = I_{LED2} = \dots = V_{FB}/R_{S1}$

Where  $I_{LEDx}$  is the desired LED current,  $V_{FB}$  is  $V_{VSET}$ , and  $R_{S1}$  is the sense resistor. To keep the LED currents as equal as possible, transistors Q1 and Q2 should be matched, and  $R_{S1}$  and  $R_{S2}$  should be matched.

**Open Load Detection by VFAULT**

The AL5817 can be configured to detect the presence of the LEDs on the external output transistor going open circuit. This function is automatically activated by VCC increasing above 4.5V. The AL5817 detects open conditions on the collector/drain of the external transistor driving the LEDs using the VFAULT pin (See Figure 5). The VFAULT pin has a 14µA current source generated out of this pin. (Blue components are internal to the AL5817).

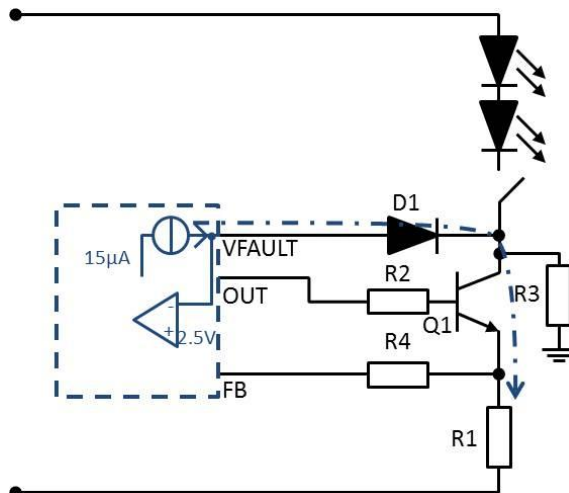

**Figure 5. LED-Open Detection Using VFAULT**

If the LED string becomes open, VFAULT pin will be pulled down by the power BJT or MOSFET below its internal 2.5V threshold. This condition triggers an output disable condition causing OUT to go low, turning off the external MOSFET/BJT. A resistor (R3, 100K) is needed to keep the VFAULT signal low during a fault condition. When the fault condition is fixed and VFAULT pin rises above 2.63V the device will operate normally.

**Feedback Loop**

The device has internal compensation for the FB loop and therefore it is not recommended that any components are added to the feedback loop.

NEW PRODUCT

**Application Information** (Cont.)

**LED Thermal Compensation**

The LED current is set by the reference voltage at the emitter/drain voltage of the LED driving transistor. This reference voltage is determined by the resistor divider between REF and VSET. The LED driver's LED current behavior under different ambient or LED temperatures can be configured by using NTC for R6 shown in Figure 6.

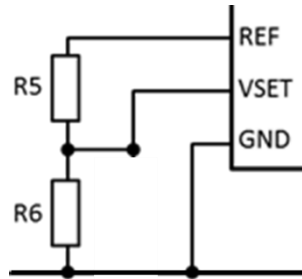

Figure 6

In the example shown in Figure 7, the resistor network is comprised of one NTC and a resistor. When the temperature of the detecting point is rising, the NTC resistance will decrease and make the voltage at VSET decrease also, consequentially, the output current will decrease to prevent the system from over-heated.

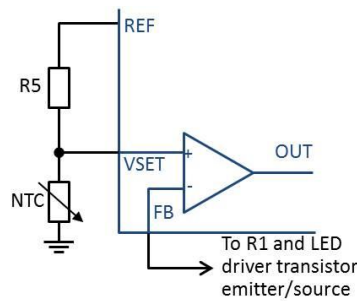

Figure 7. Thermal Fold-back Circuit Basing on NTC

**Thermal Protection**

The AL5817 has an internal Over Temperature Protection (OTP). When the junction temperature is over +160°C, the IC will shut down. When the junction temperature drops by +30°C the IC turn back on.

NEW PRODUCT

**Ordering Information** (Note 7)

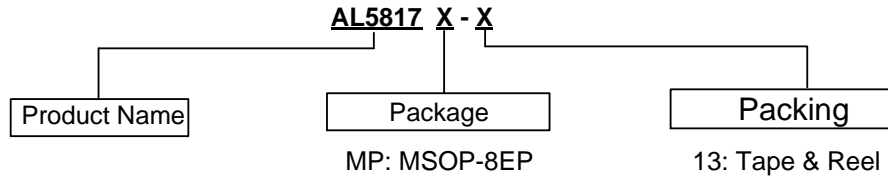

Part Number	Package Code	Packaging	13" Tape and Reel	
			Quantity	Part Number Suffix
AL5817MP-13	MP	MSOP-8EP	2500	-13

Note: 7. For packaging details, go to our website at <https://www.diodes.com/design/support/packaging/diodes-packaging/>.

**Marking Information**

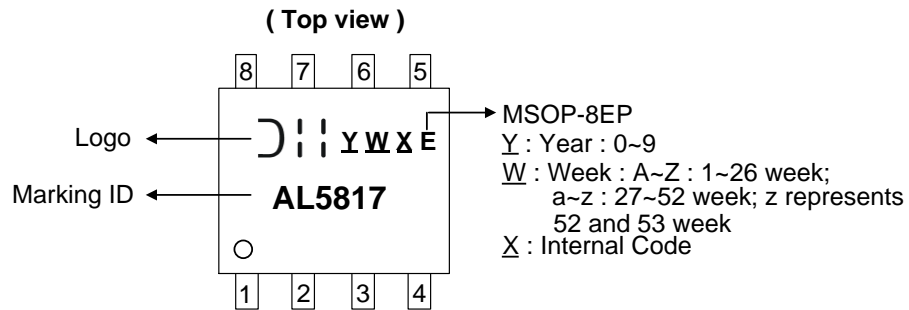

Device	Package
AL5817MP-13	MSOP-8EP

**Package Outline Dimensions**

Please see <http://www.diodes.com/package-outlines.html> for the latest version.

**MSOP-8EP**

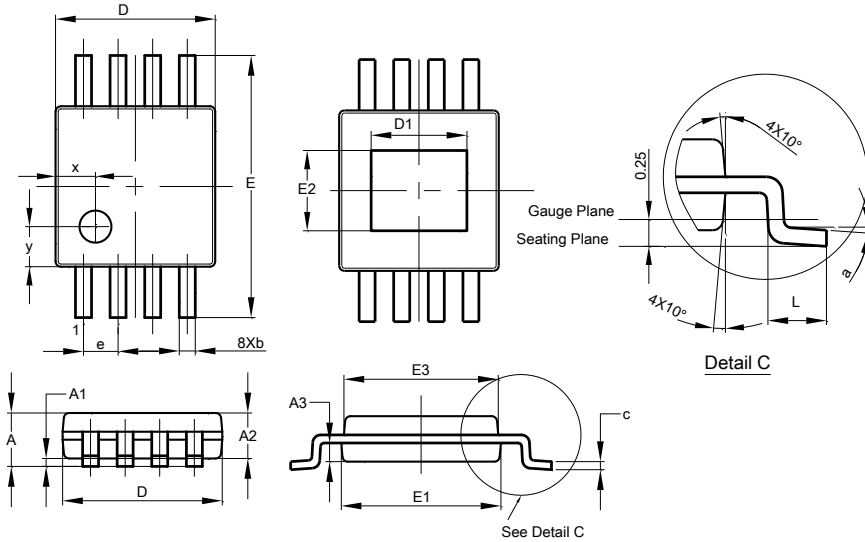

MSOP-8EP			
Dim	Min	Max	Typ
A	-	1.10	-
A1	0.05	0.15	0.10
A2	0.75	0.95	0.86
A3	0.29	0.49	0.39
b	0.22	0.38	0.30
c	0.08	0.23	0.15
D	2.90	3.10	3.00
D1	1.60	2.00	1.80
E	4.70	5.10	4.90
E1	2.90	3.10	3.00
E2	1.30	1.70	1.50
E3	2.85	3.05	2.95
e	-	-	0.65
L	0.40	0.80	0.60
a	0°	8°	4°
x	-	-	0.750
y	-	-	0.750
<b>All Dimensions in mm</b>			

**Suggested Pad Layout**

Please see <http://www.diodes.com/package-outlines.html> for the latest version.

**MSOP-8EP**

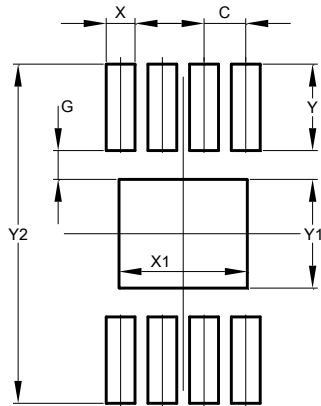

Dimensions	Value (in mm)
C	0.650
G	0.450
X	0.450
X1	2.000
Y	1.350
Y1	1.700
Y2	5.300

NEW PRODUCT