

Description

The AL8861Q is a hysteresis mode DC-DC step-down LED driver, designed for driving single or multiple series of the connected LEDs efficiently from a voltage source higher than the LED voltage. The device can operate with an input supply from 4.5V to 40V and provide an externally adjustable output current up to 1.5A for the MSOP-8EP package. Depending upon supply voltage and external components, this converter can provide up to 40W of output power.

The AL8861Q integrates the power switch and a high-side output current sensing circuit, which uses an external resistor to set the nominal average output current.

Dimming can be realized by applying an external control signal to the VSET pin. The VSET pin will accept either a DC voltage signal or a PWM (pulse-width modulation) signal.

The soft-start time can be adjusted by an external capacitor from the VSET pin to the ground. Applying a voltage of 0.2V or lower to the VSET pin can turn off the output and make the device enter into standby state with low power consumption.

The AL8861Q is qualified to AEC-Q100 Grade 1 and is automotive grade to support PPAPs.

Features

- Wide Input-Voltage Range: 4.5V to 40V
- Output Current Up to 1.5A
- Internal 40V NDMOS Switch
- Typical 5% Output Current Accuracy
- Single Pin for On/Off and Brightness Control by DC Voltage or PWM Signal
- High Efficiency (> 95%)
- LED Short-Circuit Protection
- Inherent Open-Circuit LED Protection
- Sense Resistor Short-Circuit Protection
- Overtemperature Shutdown
- Up to 1MHz Switching Frequency
- Pb-Free MSOP-8EP Package
- **Totally Lead-Free & Fully RoHS Compliant (Notes 1 & 2)**
- **Halogen and Antimony Free. "Green" Device (Note 3)**
- **The AL8861Q is suitable for automotive applications requiring specific change control; this part is AEC-Q100 qualified, PPAP capable, and manufactured in IATF16949 certified facilities.**

<https://www.diodes.com/quality/product-definitions/>

- Notes:
1. No purposely added lead. Fully EU Directive 2002/95/EC (RoHS), 2011/65/EU (RoHS 2) & 2015/863/EU (RoHS 3) compliant.
 2. See <https://www.diodes.com/quality/lead-free/> for more information about Diodes Incorporated's definitions of Halogen- and Antimony-free, "Green" and Lead-free.
 3. Halogen- and Antimony-free "Green" products are defined as those which contain <900ppm bromine, <900ppm chlorine (<1500ppm total Br + Cl) and <1000ppm antimony compounds.

Pin Assignments

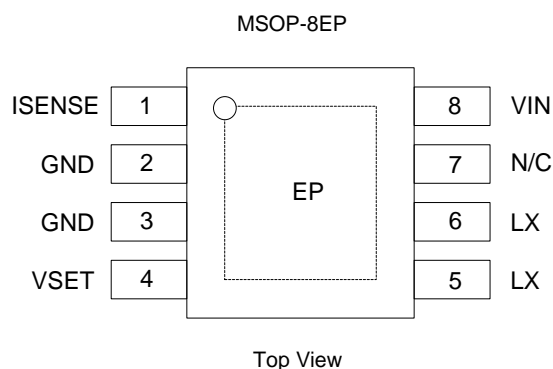

Applications

- Automotive interior LED lamps
- Automotive exterior LED lamps

Typical Applications Circuit

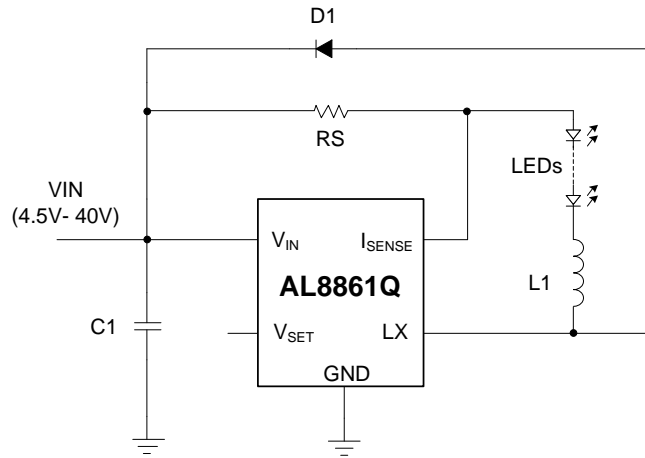

4.5V to 40V DC Input Application

Pin Descriptions

Pin Number	Pin Name	Function
1	ISENSE	Connect resistor R_s from this pin to V_{IN} to define nominal average output current. $I_{OUTNOM} = 0.1/R_s$
2, 3	GND	Ground (0V)
4	VSET	Multi-function On/Off and Brightness Control Pin: <ul style="list-style-type: none"> • Leave floating for normal operation • Drive voltage below 0.2V to turn off output current • Drive with DC voltage ($0.3V < V_{SET} < 2.5V$) to adjust output current from 0 to 100% of I_{OUTNOM}. Linear adjustment ranges from 5% to 100% of I_{OUTNOM} • Drive with PWM signal from open-collector or open-drain transistor to adjust output current. Linear adjustment ranges from 1% to 100% of I_{OUTNOM} for $f < 500Hz$ • Connect a capacitor from this pin to Ground to increase soft-start time. (Default soft-start time = 0.1ms. Additional soft-start time is approximately $1.5ms/1nF$)
5, 6	LX	Drain of NDMOS Switch.
7	N/C	No Connection
8	VIN	Input Voltage (4.5V to 40V). Decouple to Ground with $10\mu F$ or higher X7R ceramic capacitor close to device.
EP	EP	Exposed Pad. Connect to GND and thermal mass for enhanced thermal impedance. Should not be used as electrical ground conduction path.

Functional Block Diagram

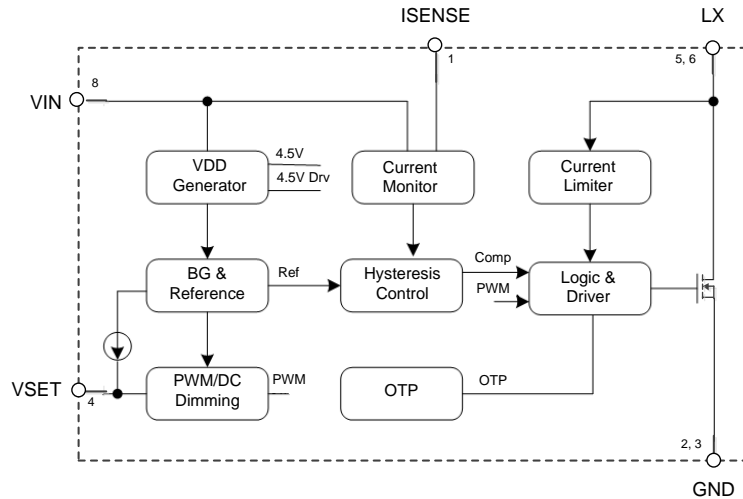

Absolute Maximum Ratings (Note 4)

Symbol	Parameter	Rating	Unit
V_{IN}	Input Voltage	-0.3 to 42	V
V_{LX}, V_{ISENSE}	LX, ISENSE Pin Voltage	-0.3 to 42	V
V_{VSET}	VSET Pin Voltage	-0.3 to 6	V
T_J	Operating Junction Temperature	-40 to +150	°C
T_{STG}	Storage Temperature Range	-65 to +150	°C
T_{LEAD}	Lead Temperature (Soldering, 10s)	+260	°C

Note: 4. Stresses greater than those listed under *Absolute Maximum Ratings* can cause permanent damage to the device. These are stress ratings only, and functional operation of the device at these or any other conditions beyond those indicated under *Recommended Operating Conditions* is not implied. Exposure to *Absolute Maximum Ratings* for extended periods can affect device reliability. Besides, if the voltage on VSET pin is higher than 5V, the device will enter the test mode for parameter test. Therefore, the voltage on VSET pin should be kept below 5V for normal operation.

ESD Ratings (Note 5)

Symbol	Parameter	Rating	Unit
V_{ESD}	Human Body Model (HBM), Per AEC-Q100-002	±3000	V
	Charged Device Model (CDM), Per AEC-Q100-011	±1000	

Note: 5. AEC-Q100-002 indicates that HBM stressing shall be accordance with the ANSI/ESDA/JEDEC JS-001 specification.

Recommended Operating Conditions

Symbol	Parameter	Min	Max	Unit
V_{IN}	Input Voltage	4.5	40	V
f_{SW}	Switching Frequency	—	1	MHz
I_{OUT}	Continuous Output Current	—	1.5	A
V_{VSET}	Voltage Range for 10% to 100% DC Dimming Relative to GND Pin	0.4	2.5	V
V_{VSET_HIGH}	Voltage High for PWM Dimming with Respect to GND Pin	2.5	5	V
V_{VSET_LOW}	Voltage Low for PWM Dimming Relative to GND Pin	0	0.3	V
T_A	Operating Ambient Temperature	-40	+125	°C

Thermal Information (Note 6)

Symbol	Parameter	Rating	Unit
θ_{JA}	Junction-to-Ambient Thermal Resistance	56	°C/W
θ_{JC}	Junction-to-Case (Top) Thermal Resistance	15	°C/W

Note: 6. Device mounted on 2" x 2" FR-4 substrate PC board, 2oz copper, with minimum recommended pad layout.

Electrical Characteristics (@ $T_A = -40^\circ\text{C}$ to $+125^\circ\text{C}$, unless otherwise specified.)

Symbol	Parameter	Conditions	Min	Typ	Max	Unit
INPUT VOLTAGE						
V_{IN}	Input Voltage	—	4.5	—	40	V
V_{INSU}	Internal Regulator Startup Threshold	—	—	3.8	4.5	V
V_{INSH}	Internal Regulator Hysteresis Threshold	—	200	—	630	mV
I_Q	Quiescent Current	VSET Pin Floating, $V_{IN} = 16\text{V}$	—	0.55	—	mA
I_{SHDN}	Shutdown Supply Current	VSET Pin Grounded	—	55	100	μA
HYSTERESTIC CONTROL						
V_{SENSE}	Mean Current-Sense Threshold Voltage	Measured on ISENSE Pin with Respect to VIN Pin ($T_A = +25^\circ\text{C}$)	96	100	104	mV
		Measured on ISENSE Pin with Respect to VIN Pin ($T_A = -40^\circ\text{C}$ to $+125^\circ\text{C}$)	95	100	105	mV
V_{SENSE_HYS}	Sense Threshold Hysteresis	—	—	± 13	—	%
I_{SENSE}	ISENSE Pin Input Current	$V_{SENSE} = V_{IN} - 0.1\text{V}$	—	8	—	μA
ENABLE						
V_{EN}	Input Voltage Range on VSET Pin	For Analog Dimming	0.3	—	2.5	V
	Analog Dimming Range	For Analog Dimming	5	—	100	%
V_{EN_ON}	DC Voltage on VSET Pin to Enable	V_{EN} Rising	—	0.25	—	V
V_{EN_OFF}	DC Voltage on VSET Pin to Disable	V_{EN} Falling	—	0.2	—	V
SWITCHING OPERATION						
R_{ON}	LX Pin Switch On-Resistance	@ $I_{LX} = 100\text{mA}$	—	0.2	—	Ω
I_{LX_LEAK}	LX Pin Switch Leakage Current	—	—	—	5	μA
t _{SS}	Soft-Start Time	$V_{IN} = 16\text{V}$, $C_{EN} = 1\text{nF}$	—	1.5	—	ms
f _{SW}	Operating Frequency	$V_{IN} = 16\text{V}$, $V_O = 9.6\text{V}$ (3 LEDs), $L = 47\mu\text{F}$, $I = 0.25\text{A}$ ($I_{LED} = 1\text{A}$)	—	250	—	kHz
t _{ON_REC}	Recommended Minimum Switch On Time	For 4% Accuracy	—	500	—	ns
f _{LX_MAX}	Recommended Maximum Switch Frequency	—	—	—	1.0	MHz
DL _{X_MAX}	Maximum Duty Cycle	—	—	98	—	%
t _{PD}	Internal Comparator Propagation Delay (Note 7)	—	—	100	—	ns
$I_{LX(MAX)}$	Current Limit for Internal Power Switch	—	2	—	—	A
THERMAL SHUTDOWN						
T_{OTP}	Overtemperature Protection	—	—	+150	—	°C
T_{OTP_HYS}	Temperature Protection Hysteresis	—	—	+30	—	°C

Note: 7. Guaranteed by design.

Typical Performance Characteristics (@ $T_A = +25^\circ\text{C}$, $V_{IN} = 16\text{V}$, unless otherwise specified.)

Quiescent Current vs. Input Voltage

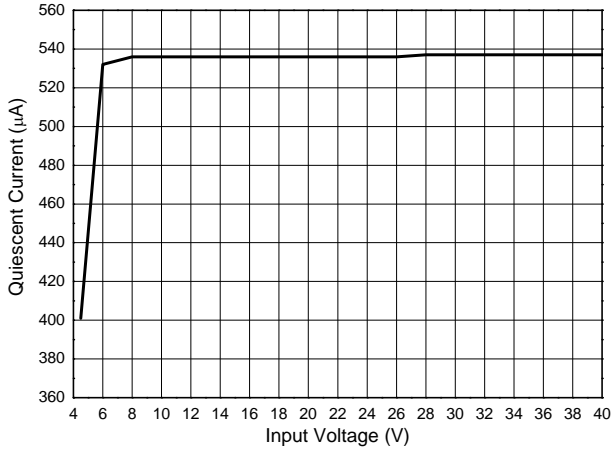

Quiescent Current vs. Temperature

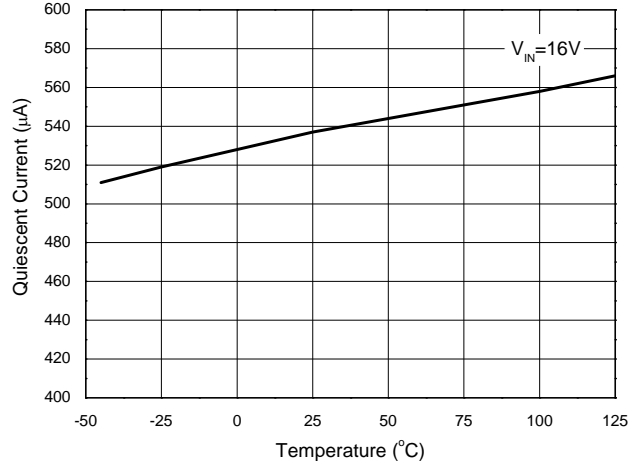

Shutdown Current vs. Input Voltage

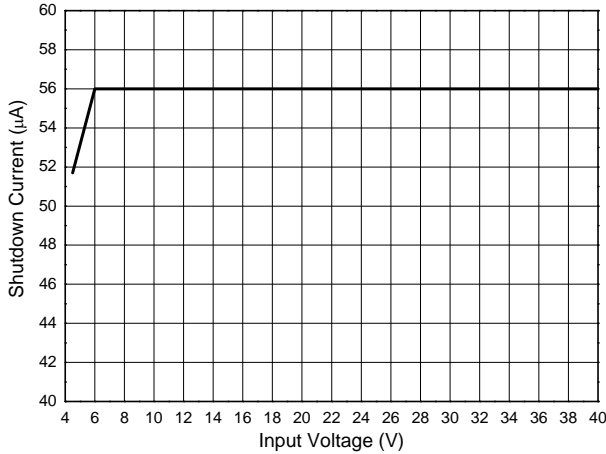

Shutdown Current vs. Temperature

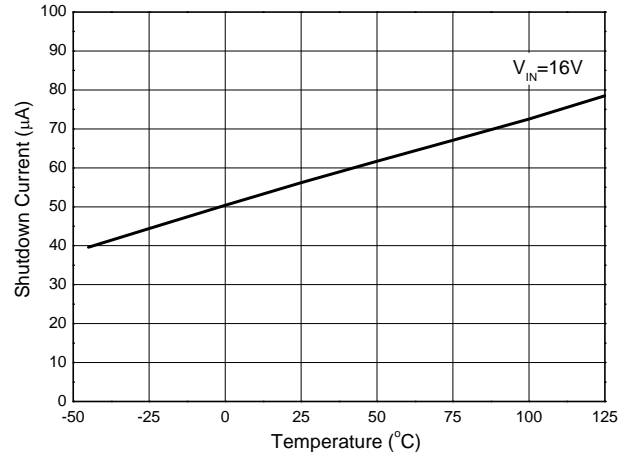

I_{SENSE} Threshold Voltage vs. Input Voltage

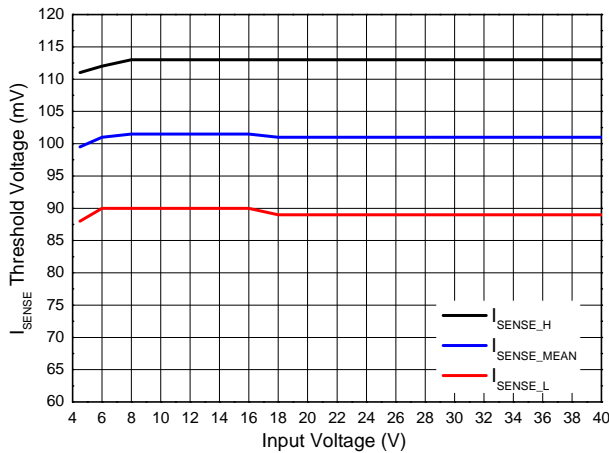

**PWM Dimming ($V_{IN}=16\text{V}$, 3 LEDs, $L=47\mu\text{H}$, $R_S=0.3\Omega$)
LED Current vs. Duty Cycle**

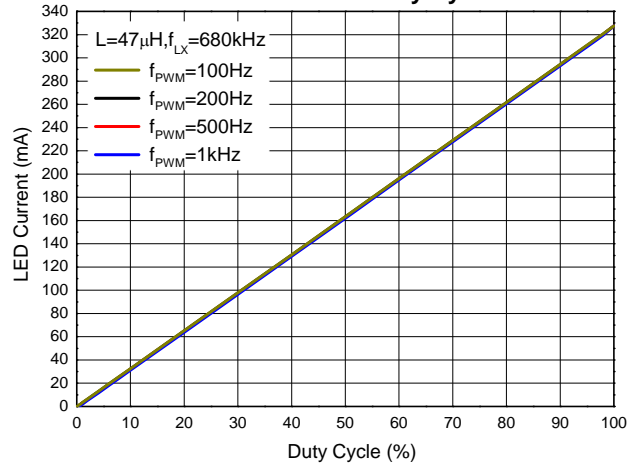

Typical Performance Characteristics (@ $T_A = +25^\circ\text{C}$, $V_{IN} = 16\text{V}$, unless otherwise specified.) (continued)

Analog Dimming ($V_{IN}=16\text{V}$, 3 LEDs, $L=47\mu\text{H}$, $R_S=0.3\Omega$)
LED Current vs. VSET Pin Voltage

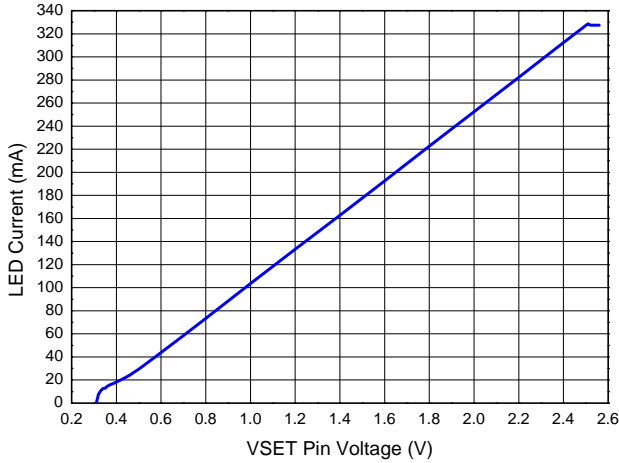

Efficiency vs. Input Voltage
($R_S=0.1\Omega$, $L=68\mu\text{H}$)

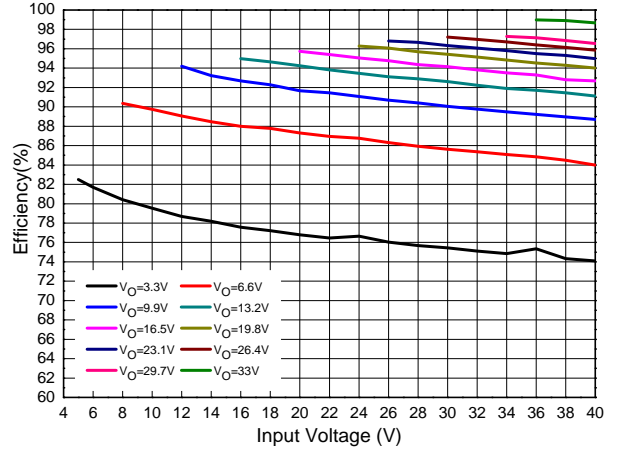

Efficiency vs. Input Voltage
($R_S=0.067\Omega$, $L=47\mu\text{H}$)

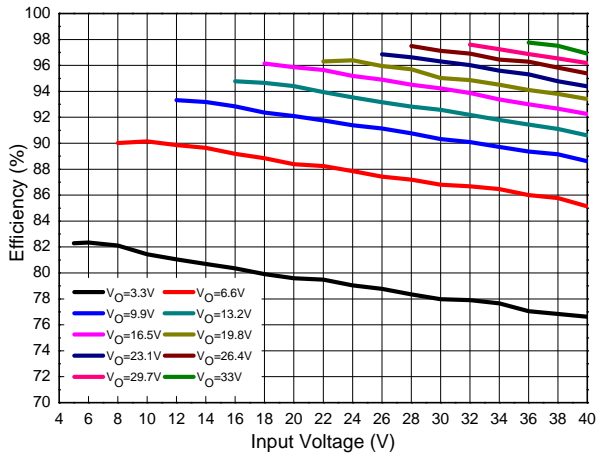

LED Current vs. Input Voltage
($R_S=0.1\Omega$, $L=68\mu\text{H}$)

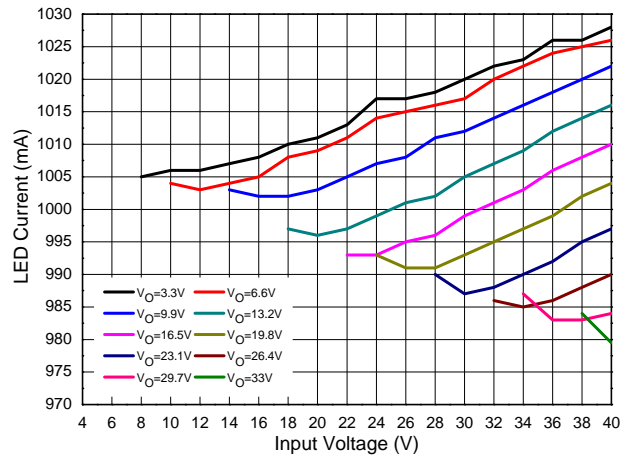

LED Current vs. Input Voltage
($R_S=0.067\Omega$, $L=47\mu\text{H}$)

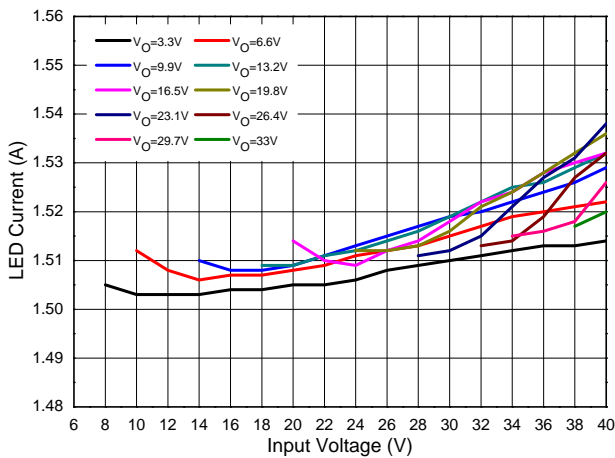

Operating Frequency vs. Input Voltage
($R_S=0.1\Omega$, $L=68\mu\text{H}$)

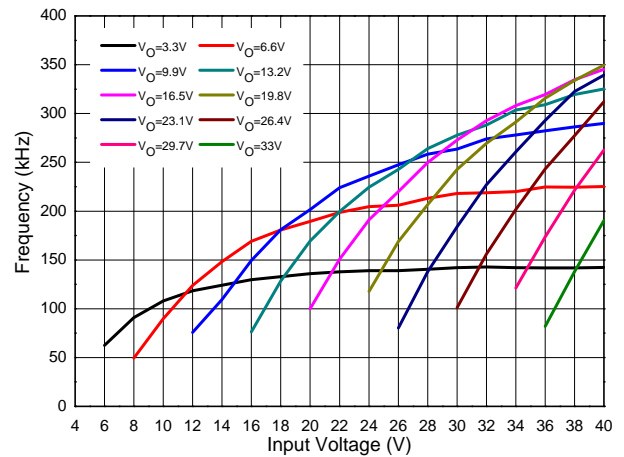

Typical Performance Characteristics (@ $T_A = +25^\circ\text{C}$, $V_{IN} = 16\text{V}$, unless otherwise specified.) (continued)

Operating Frequency vs. Input Voltage
($R_S=0.067\Omega$, $L=47\mu\text{H}$)

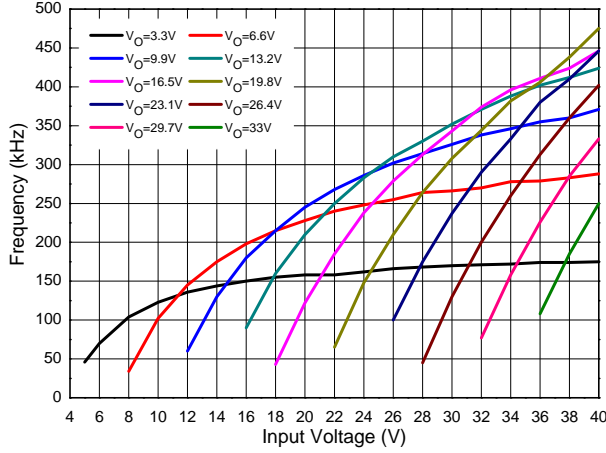

LED Current vs. Output Voltage
($R_S=0.1\Omega$, $L=68\mu\text{H}$)

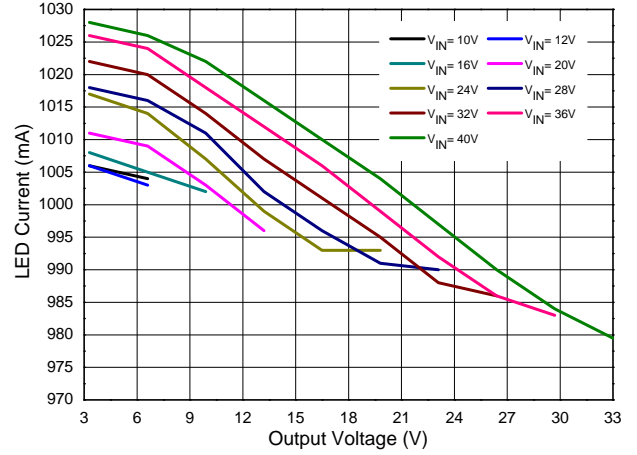

LED Current vs. Output Voltage
($R_S=0.067\Omega$, $L=47\mu\text{H}$)

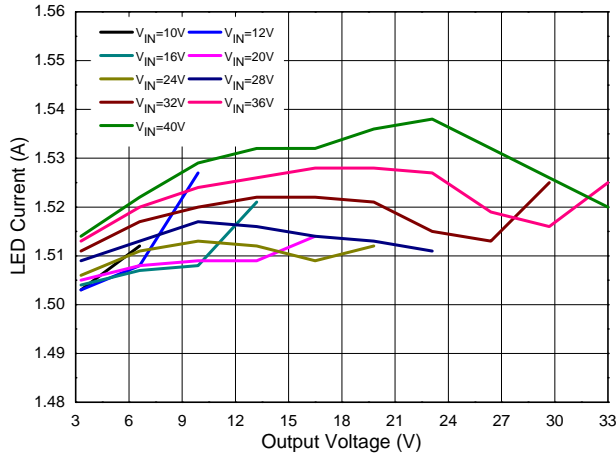

Switching Duty Cycle vs. Supply Voltage
($R_S=0.067\Omega$, $L=68\mu\text{H}$)

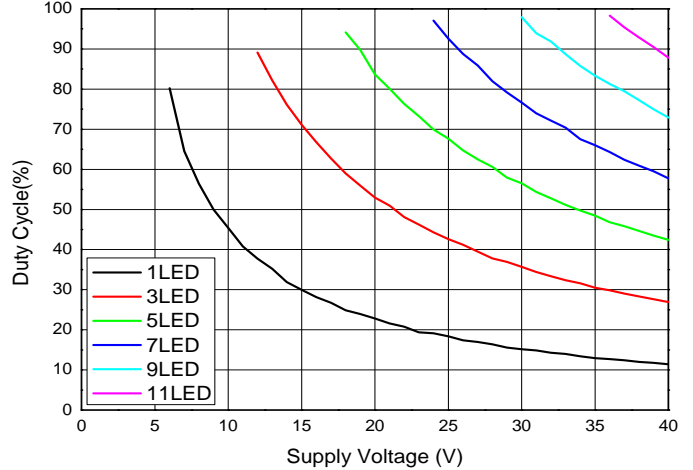

Performance Characteristics (@ $V_{IN} = 16V$, 3 LEDs, $R_S = 0.3\Omega$, $L = 47\mu H$, $T_A = +25^\circ C$, unless otherwise specified.)

Steady State

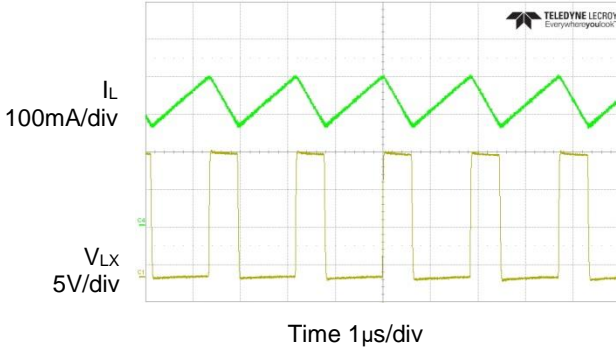

Startup Delay Time

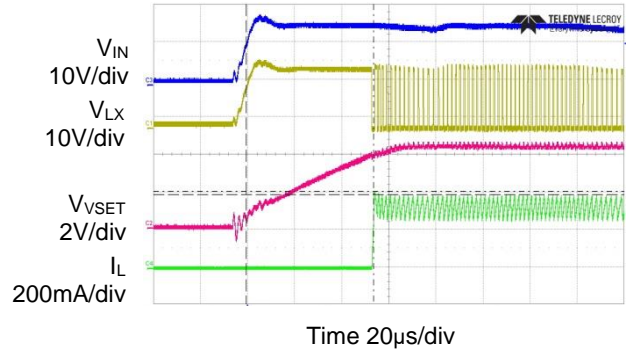

PWM Dimming (100Hz, Duty=50%)

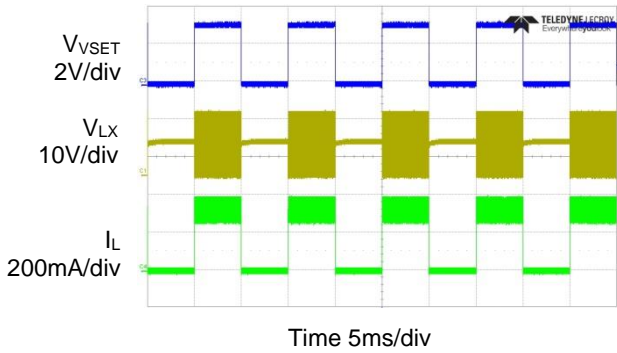

Pulse Skip Mode

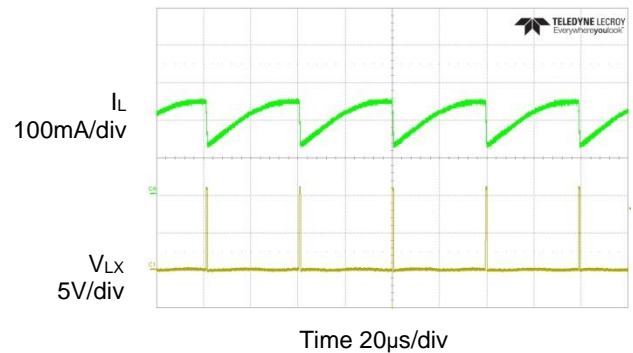

LED Open Protection

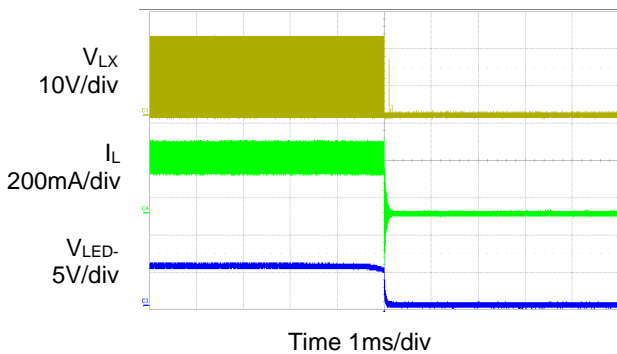

RS Short Protection

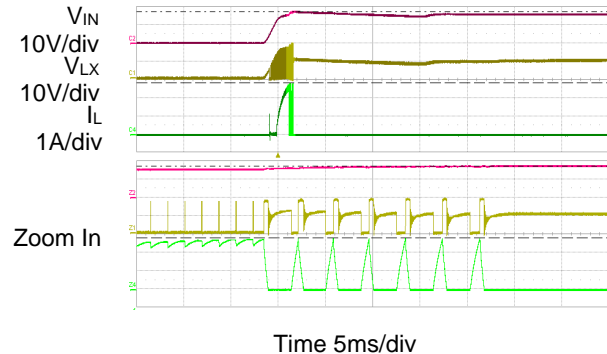

Application Information

The AL8861Q is a hysteretic mode LED driver with integrated power switch, and is available in the thermally enhanced MSOP-8EP package.

AL8861Q Operation

In normal operation, when normal input voltage is applied at VIN pin, the AL8861Q internal switch will turn on. Current starts to flow through the sense resistor Rs, inductor L1, and the LEDs. The current ramps up linearly, and the slew rate is determined by the input voltage VIN, VOUT and the inductor L1.

This rising current produces a voltage ramp across Rs. The internal circuit of the AL8861Q senses the voltage across Rs and applies a proportional voltage to the input of the internal comparator. When this voltage reaches an internal set upper threshold, the internal switch is turned off. The inductor current continues to flow through Rs, L1, LEDs and diode D1, and back to the supply rail, but it decays with the rate determined by the forward voltage drop of LEDs and the diode D1.

This decaying current produces a falling voltage on Rs, which is sensed by the AL8861Q. A voltage proportional to the sense voltage across Rs will be applied at the input of internal comparator. When this voltage falls to the internal lower-set threshold, the internal switch is turned on again.

This switch-on-and-off cycle continues to provide the average LED current set by the sense resistor Rs.

LED Current Configuration

The nominal average output current in the LED(s) is determined by the value of the external current-sense resistor (Rs) connected between VIN pin and ISENSE pin, and is given by:

$$I_{OUT(NOM)} = \frac{0.1}{R_s}$$

The table below provides values of the nominal average output current for setting resistor (Rs) in the *Typical Applications Circuit* shown on page 2.

Rs (Ω)	Nominal Average Output Current (mA)
0.066	1500
0.1	1000
0.13	760
0.15	667
0.3	333

The above values assume that the VSET pin is floating and at a nominal reference voltage for internal comparator. It is possible to use different values of Rs if the VSET pin is driven by an external dimming signal.

Analog Dimming

Applying a DC voltage from 0.3V to 2.5V on the VSET pin can adjust output current from 0 to 100% of IOUTNOM, as shown in Figure 1. The recommended dimming range is from 5% to 100%. If the VSET pin is brought higher than 2.5V, the LED current will be clamped to 100% of IOUTNOM. And the output switch will turn off if the VSET pin voltage falls below the threshold of 0.3V.

PWM Dimming

The LED current can be adjusted digitally by applying a low-frequency pulse-width-modulated (PWM) logic signal to the VSET pin to turn the device on and off. This will produce an average output current proportional to the duty cycle of the control signal. To achieve a high resolution, the PWM frequency is recommended to be lower than 500Hz. However, high dimming frequencies can be used at the expense of dimming dynamic range and accuracy. Typically, for a PWM frequency of 500Hz, the accuracy is better than 1% for PWM ranging from 1% to 100%.

The accuracy of the low duty-cycle dimming is affected by both the PWM frequency and the switching frequency of the AL8861Q. For best accuracy/resolution, the switching frequency should be increased while the PWM frequency should be reduced.

The VSET pin is designed to be driven by 3.3V logic level directly from a logic output with either an open-drain output or a push-pull output stage.

Application Information (continued)

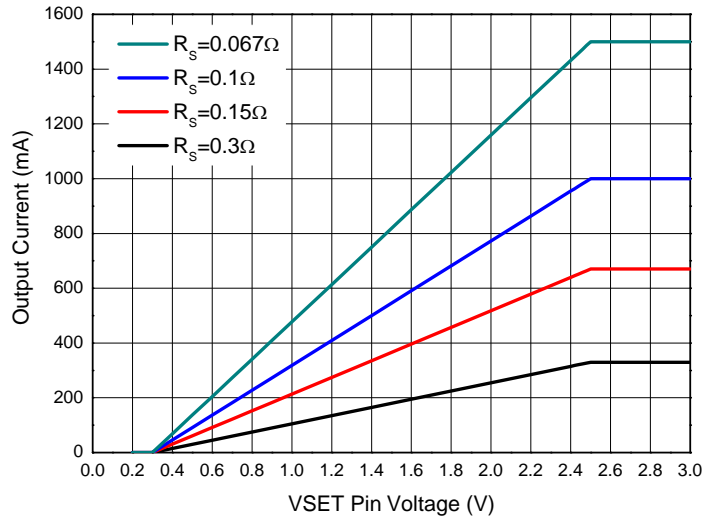

Figure 1. Analog Dimming Curve

Soft-Start

The default soft-start time for AL8861Q is 0.1ms, providing very fast turn-on of the output and improving the PWM dimming accuracy.

Nevertheless, adding an external capacitor from the VSET pin to ground will provide a longer soft-start delay. This is achieved by increasing the time of the VSET voltage rising to the turn-on threshold, and by slowing down the rising rate of the control voltage at the input of hysteresis comparator. The additional soft-start time is related to the capacitance between the VSET pin and GND pin, and the typical value will be 1.5ms/nF.

Capacitor Selection

A low ESR capacitor should be used for input decoupling, as the ESR of this capacitor appears in series with the supply source impedance and will reduce the overall efficiency. This capacitor can supply the relatively high peak current to the coil and smooth the ripple on the input current.

The minimum capacitance needed is determined by input power, cable's length and peak current. 4.7μF to 10μF is a commonly used value for most cases. A higher value will improve the performance at lower input voltages, especially when the source impedance is high. The input capacitor should be placed as close as possible to the IC.

For maximum stability of overtemperature and voltage, capacitors with X7R, X5R or better dielectric are recommended. Capacitors with Y5V dielectric are not suitable for decoupling in this application and should NOT be used.

Diode Selection

For maximum efficiency and performance, the freewheeling diode (D1) should be a fast low capacitance Schottky diode with low reverse leakage current. It also provides better efficiency than the silicon diodes, due to the lower forward voltage and reduced recovery time.

It is important to select parts with a peak current rating above the peak coil current, and a continuous current rating higher than the maximum output load current. It is very important to control the reverse leakage current of the diode when operating above +85°C. Excess leakage current will increase power dissipation.

The higher forward voltage and overshoot due to the reverse-recovery time in silicon diodes will increase the peak output voltage on the LX pins. If a silicon diode is used, more care should be taken to ensure that the total voltage appearing on the LX pins including supply ripple won't exceed the specified maximum value.

Application Information (continued)

Inductor Selection

Recommended inductor values for the AL8861Q is in the range of 33μH to 100μH. Higher inductance is recommended at higher supply voltages in order to minimize output current tolerance due to switching delays, which will result in the increased ripple and lower efficiency. Higher inductance also results in a better line regulation. The inductor should be mounted as close to the device as possible with low resistance connections to LX pins.

The chosen coil should have saturation current higher than the peak output current and a continuous current rating above the required mean output current.

The inductor value should be chosen to maintain operating duty cycle and switch on/off times within the specified limits over the supply voltage and load current range. The following equations can be used as a guide.

LX Pin Switch On Time

$$t_{ON} = \frac{L\Delta I}{V_{IN} - V_{LED} - I_{LED}(R_S + R_L + R_{LX})}$$

LX Pin Switch Off Time

$$t_{OFF} = \frac{L\Delta I}{V_{LED} + V_D + I_{LED}(R_S + R_L)}$$

Where: L is the coil inductance; R_L is the coil resistance; R_S is the current sense resistance; I_{LED} is the required LED current; ΔI is the coil peak-peak ripple current (internally set to 0.26 x I_{LED}); V_{IN} is the supply voltage; V_{LED} is the total LED forward voltage; R_{LX} is the switch resistance (0.2Ω nominal); V_D is the diode forward voltage at the required load current.

Thermal Protection

The AL8861Q includes overtemperature protection (OTP) circuitry that will turn off the device if its junction temperature gets too high. This is to protect the device from excessive heat damage. The OTP circuitry includes thermal hysteresis that will cause the device to restart normal operation once its junction temperature has cooled down by approximately +30°C.

Open-Circuit LEDs

The AL8861Q has the default open LED protection. If the LEDs become open-circuit, the AL8861Q will stop oscillating; the voltage at the ISENSE pin will rise to the voltage at the VIN pin, and the voltage at the LX pin will then fall to the voltage at the GND. No excessive voltages will be seen by the AL8861Q.

LED Chain Shorted Together

If the LED chain becomes shorted together (the anode of the top LED becomes shorted to the cathode of the bottom LED), the AL8861Q will continue to switch and the current through the AL8861Q's internal switch will still be at the expected current—so no excessive heat will be generated within the AL8861Q. However, the duty cycle will change dramatically and the switching frequency will most likely decrease. See Figure 2 for an example of this behavior at 24V input voltage driving 3 LEDs.

The on-time of the internal power MOSFET switch is significantly reduced because almost all of the input voltage is now developed across the inductor. The off-time is significantly increased because the reverse voltage across the inductor is now just the Schottky diode voltage (See Figure 2) causing a much slower decay in inductor current.

Application Information (continued)

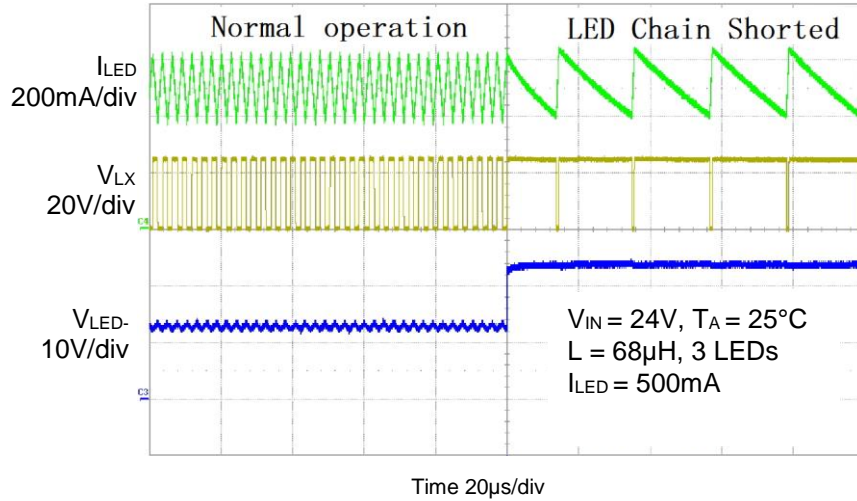

Figure 2. Switching Characteristics (Normal Operation to LED Chain Shorted Out)

Sense Resistor Short-Circuit Protection

The AL8861Q has a current limit at about 2.8A. If R_s is shorted, current limit is triggered for accumulated 7 times and the switch will shut down and latch up.

EMI (Electromagnetic Interference) and Layout Considerations

The AL8861Q is a switching regulator with fast edges and measures small differential voltages; as a result, care has to be taken with decoupling and layout of the PCB. To help with these effects, the AL8861Q has been developed to minimize radiated emissions by controlling the switching speeds of the internal power MOSFET. The rise and fall times are controlled to get the right compromise between power dissipation due to switching losses and radiated EMI. The turn-on edge (falling edge) dominates the radiated EMI which is due to an interaction among the Schottky diode (D1), Switching MOSFET and PCB tracks. After the Schottky diode reverse-recovery time of around 5ns has occurred, the falling edge of the LX pin sees a resonant loop between the Schottky diode capacitance and the track inductance, L_{TRACK}. See Figure 3.

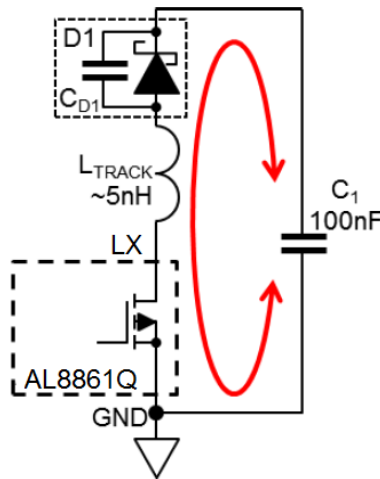

Figure 3. PCB Loop Resonance

The tracks from the LX pin to the Anode of the Schottky diode, D1, and then from D1's cathode to the decoupling capacitors C1 should be as short as possible. There is an inductance internally in the AL8861Q which can be assumed to be around 1nH. For PCB tracks, a figure of 0.5nH per mm can be used to estimate the primary resonant frequency. If the track is capable of handling 1A, increasing the thickness will have a minor effect on the inductance and length will dominate the size of the inductance. The resonant frequency of any oscillation is determined by the combined inductance in the track and the effective capacitance of the Schottky diode.

Application Information (continued)

Recommendations for minimizing radiated EMI and other transients and thermal considerations are:

1. The decoupling capacitor (C1) has to be placed as close as possible to the VIN pin and D1 cathode.
2. The freewheeling diode's (D1) anode, the LX pin and the inductor have to be placed as close as possible to each other to avoid ringing.
3. The Ground return path from C1 must be a low impedance path with the ground plane as large as possible.
4. The LED current sense resistor (Rs) has to be placed as close as possible to the VIN and ISENSE pins.
5. The majority of the conducted heat from the AL8861Q is through the GND pin 2. A maximum earth plane with thermal vias into a second earth plane will minimize self-heating.
6. To reduce emissions via long leads on the supply input and LEDs, low RF impedance capacitors should be used at the point where the wires are joined to the PCB.

Ordering Information (Note 8)

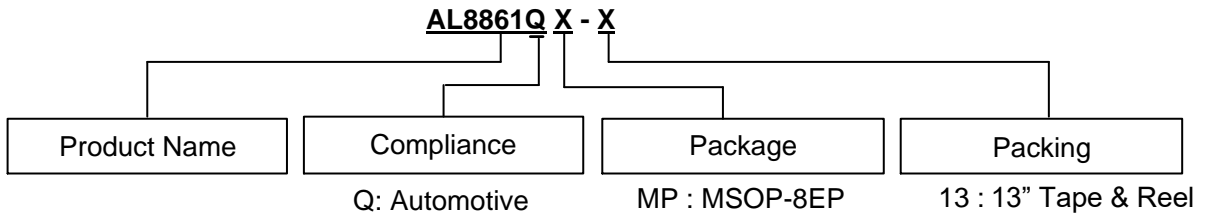

Part Number	Part Number Suffix	Package Code	Package	Packing	
				Qty.	Carrier
AL8861QMP-13	-13	MP	MSOP-8EP	2500	13" Tape & Reel

Note: 8. For packaging details, go to our website at <https://www.diodes.com/design/support/packaging/diodes-packaging/>.

Marking Information

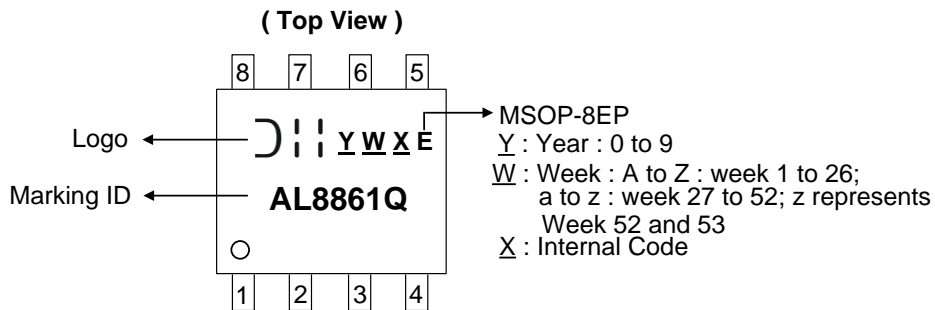

Part Number	Package	Marking ID
AL8861QMP-13	MSOP-8EP	AL8861Q

Package Outline Dimensions

Please see <http://www.diodes.com/package-outlines.html> for the latest version.

MSOP-8EP

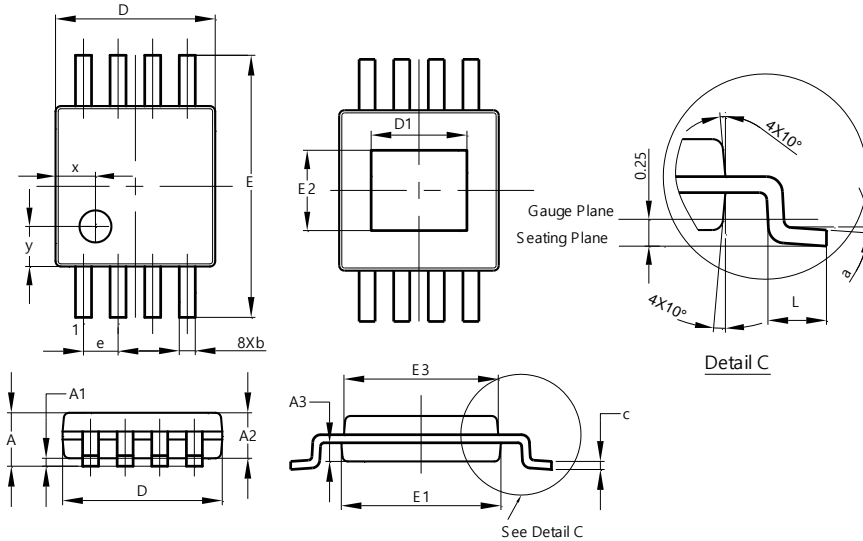

MSOP-8EP			
Dim	Min	Max	Typ
A	-	1.10	-
A1	0.05	0.15	0.10
A2	0.75	0.95	0.86
A3	0.29	0.49	0.39
b	0.22	0.38	0.30
c	0.08	0.23	0.15
D	2.90	3.10	3.00
D1	1.60	2.00	1.80
E	4.70	5.10	4.90
E1	2.90	3.10	3.00
E2	1.30	1.70	1.50
E3	2.85	3.05	2.95
e	-	-	0.65
L	0.40	0.80	0.60
a	0°	8°	4°
x	-	-	0.750
y	-	-	0.750
All Dimensions in mm			

Suggested Pad Layout

Please see <http://www.diodes.com/package-outlines.html> for the latest version.

MSOP-8EP

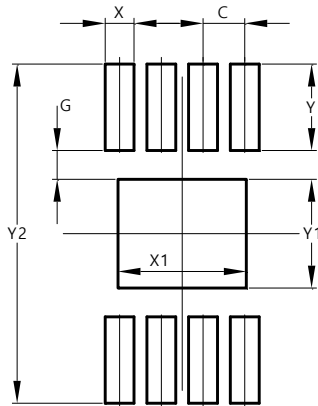

Dimensions	Value (in mm)
C	0.650
G	0.450
X	0.450
X1	2.000
Y	1.350
Y1	1.700
Y2	5.300

Mechanical Data

- Moisture Sensitivity: Level 1 per JESD22-A113
- Terminals: Finish - Matte Tin Plated Leads, Solderable per M2003 JESD22-B102 ③
- Weight: 0.026 grams (Approximate)