

10/100 Base-T Single Port LAN Transformer w/ PoE Extended Temperature 3 Cores Solution

ALAN-2201

RoHS/RoHS II Compliant

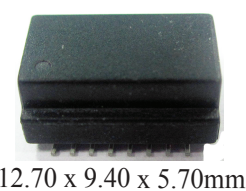

12.70 x 9.40 x 5.70mm

FEATURES:

- Meet IEEE802.3 specification
- Power Over Ethernet(PoE) IEEE802.3af compliant performance
- Extended Temperature (-40°C - +85°C)
- ROHS peak reflow temperature rating 245°C
- 1500Vrms Hi-Pot

APPLICATIONS:

- Designed for most leading PHY IC manufacturers such as Broadcom, Marvell, Micrel, & Microsemi
- 10/100Base-T Ethernet-LAN
- VoIP/PoE Capabilities
- Symmetrical Tx & RX channels for Auto MDI/MDIX capability
- Provides signal conditioning, EMI suppression and signal isolation.
- Hubs/Switches/Routers/Servers/NIC Cards

STANDARD SPECIFICATIONS:

Key Electrical Specifications @ 25°C

Parameters	Minimum	Typical	Maximum	Units	Notes
Operating Temperature	-40		+85	°C	
Storage Temperature	-40		+85	°C	
Turn Ratio (± 5%)		1CT:1CT			
Inductance (OCL)	350			μH	100KHz/0.1V@8mA
Leakage Inductance (LL)			0.5	μH	100KHz/0.1V
Cw/w			30	pF	100KHz/0.1V
DC Resistance			1.2	Ω	
Insertion Loss			-1.1	dB	1-100MHz
Return Loss	-18			dB	1-30MHz
	-16				40MHz
	-13				50MHz
	-12				60-80MHz
Cross Talk		-30		dB	1-100MHz
Differential to Common Mode Rejection	-30			dB	1-100MHz
Common Mode Rejection	-30			dB	1-100MHz
PoE Current Capacity			350	mA	
Hi-Pot	1500Vrms				

OUTLINE DIMENSIONS:

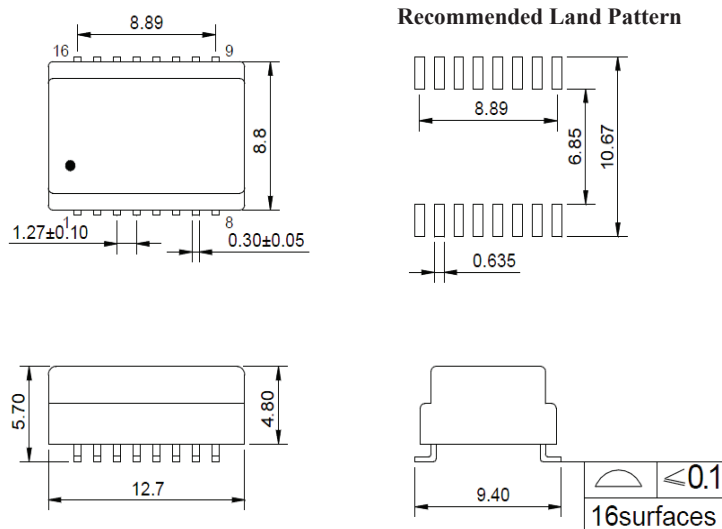

Dimensions: mm (Unless otherwise specified, tolerances are ±0.25)

Dimension: mm

ABRACON IS
ISO 9001:2008
CERTIFIED

 **ABRACON**[®]
The Power of Linking Together

2 Faraday, Suite# B | Irvine | CA 92618 Revised: 03.13.15
Ph. 949.546.8000 | Fax. 949.546.8001
Visit www.abracon.com for Terms and Conditions of Sale

10/100 Base-T Single Port LAN Transformer w/ PoE Extended Temperature 3 Cores Solution

ALAN-2201

RoHS/RoHS II Compliant



12.70 x 9.40 x 5.70mm

SCHEMATICS

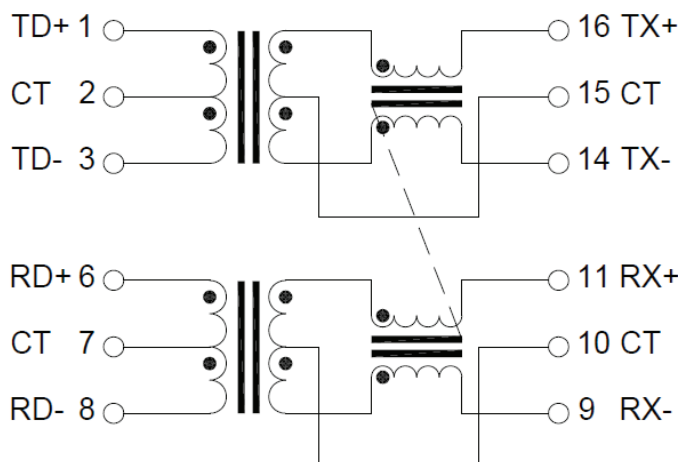

REFLOW PROFILE:

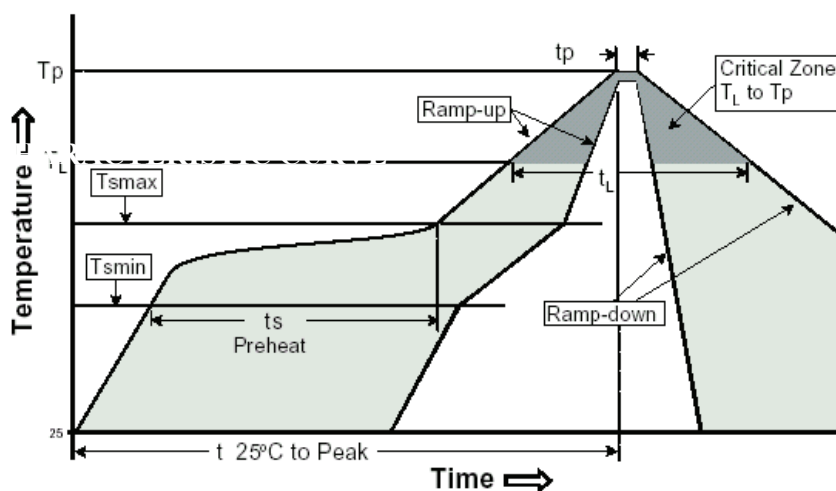

Profile Feature	Pb-Free Assembly
Average Ramp-Up Rate (T _{s max} to T _p)	3°C /second max.
Preheat	
-Temperature Min (T _{s min})	150°C
-Temperature Max (T _{s max})	200°C
-Time (t _{s min} to t _{s max})	60-120 seconds
Time maintained above:	
-Temperature (T _L)	217°C
-Time (t _L)	60-150 seconds
Peak/Classification Temperature (T _p)	245±5°C
Time within 5°C of actual Peak Temperature (t _p)	20-40 seconds
Ramp-Down Rate	6°C /seconds max
Time 25°C to Peak Temperature	8 minutes max.