



# Reference Manual

---

## Double Pulse Evaluation Board

Revision :

First Edition Date : March 16, 2023

Revision Date : March 16, 2023

# table of contents

- 1. Please read before you begin ..... 4**
  - 1.1. Important Notes ..... 4
    - 1.1.1. Please read first..... 4
    - 1.1.2. Applications of this board ..... 4
    - 1.1.3. Customers who expect to use this board..... 4
    - 1.1.4. Precautions when using this board..... 4
    - 1.1.5. Board Improvement Policy..... 4
    - 1.1.6. About Board RMA..... 4
    - 1.1.7. Figures and photos..... 4
  - 1.2. Developer ..... 5
  - 1.3. Inquiries ..... 5
  - 1.4. Disclaimer and precautions for use..... 5
- 2. For Ensuring Safe Use ..... 6**
  - 2.1. Legend..... 6
  - 2.2. Cautions ..... 6
- 3. Please check when opening ..... 8**
- 4. Functions and features of this board..... 9**
  - 4.1. Main features ..... 9
  - 4.2. Board Specifications ..... 9
  - 4.3. Block Diagram ..... 11
  - 4.4. Electrical characteristics ..... 13
- 5. Components of this board ..... 14**
  - 5.1. LED display ..... 14
  - 5.2. Connector Pin Assignment ..... 15
  - 5.3. Power supply circuit for gate drive ..... 17
    - 5.3.1. How to adjust for positive bias ..... 17
    - 5.3.2. How to adjust for negative bias..... 18
  - 5.4. Gate drive circuit..... 18
  - 5.5. Snubber circuit..... 21
    - 5.5.1. RC Device Snubber..... 21
    - 5.5.2. RC Bus Snubber..... 22
- 6. Device measurement methods ..... 23**
  - 6.1. VDS, VGS measurement..... 23
  - 6.2. Current measurement with C T..... 24
  - 6.3. Measurement with a Rogowski current probe..... 24

6.4. Measurement with coaxial shunt resistors .....25

6.5. Double Pulse Evaluation Procedure .....25

# 1. Please read before you begin

## 1.1. Important Notes

### 1.1.1. Please read first

- Please be sure to read this reference manual before using this board.
- Keep this reference manual for reference when needed.
- Use the board with a thorough understanding of its configuration.

### 1.1.2. Applications of this board

- The board is designed for double-pulse evaluation, which is common in evaluating power switching devices such as SiC FETs. The half-bridge circuit configuration includes the necessary gate drivers and power supply circuits, making it easy to evaluate switching characteristics. Please follow this application to use this board correctly.
- 

### 1.1.3. Customers who expect to use this board

- This board should only be used by people who have read and understood this material carefully. When handling high voltages, use only in environments where you fully understand the dangers and take appropriate measures. Basic knowledge of the switching device to be evaluated is also required.

### 1.1.4. Precautions when using this board

- This board is an evaluation support board for use in the customer's development and evaluation phase. This board cannot be commercialized or sold by incorporating it into the customer's equipment. In addition, be sure to check whether the developed circuit can be used through integrated testing, evaluation, or experiments.
- Macnica Co., Ltd. (hereinafter referred to as "Macnica") is not responsible for any consequences arising from the use of this board.
- Macnica will endeavor to provide workarounds for board defects or to repair defects for a fee or free of charge. However, in any case, we do not guarantee that a workaround will be provided or that the defect will be repaired.
- Macnica does not anticipate all potential hazards. Therefore, the warnings and cautions contained on this board or in the Reference Manual do not include all warnings and cautions. It is your responsibility to use this board correctly and safely.
- In particular, when using this board at high voltage, use it in an environment where sufficient safety measures have been taken. Macnica is not responsible for accidents or injuries caused when using this board.
- Even if there is a problem with the device installed on this board, it will not be replaced with a defective fixed product of the device.
- If this board is modified or damaged by the customer, it cannot be replaced.
- This board uses lead-free products.
- The rights to the trademarks and registered trademarks of each vendor described in this manual belong to each vendor.

### 1.1.5. Board Improvement Policy

- Macnica is constantly improving its boards in terms of design, performance and safety.
- Macnica reserves the right to make any or all changes to the board's documentation, reference manuals, designs and specifications at any time without notice to you.

### 1.1.6. About Board RMA

For initial defects within 30 days after delivery of the board, we will replace it free of charge.

However, please note that free replacement is not available in the following cases.

- (1) Misuse of the board or damage to the board in situations that are not normally used
- (2) Modify or repair the board
- (3) Damage caused by fire, earthquake, falling board or other accident

### 1.1.7. Figures and photos

Diagrams and photos may differ from the actual board you have.

## 1.2. Developer

Macnica Corporation Altima Company

〒222-8561 1-6-3 Shin-Yokohama, Kohoku-ku, Yokohama

## 1.3. Inquiries

Please contact the distributor you purchased from or from the inquiry form on the web below.

On the Mpression brand website contact page:

[https://www.macnica.co.jp/business/semiconductor/support/others/mpression\\_contact/](https://www.macnica.co.jp/business/semiconductor/support/others/mpression_contact/)

## 1.4. Disclaimer and precautions for use

If you have obtained materials from our company, please read the following usage precautions before use.

- Unauthorized reproduction of drawings and all other materials in this material is prohibited.
- This material is subject to change without notice.
- We have made every effort to prepare this document, but if you have any questions, errors, omissions, or other concerns, please let us know at the following address.

**Macnica Corporation**

**Mpression Marketing and Development**



**〒108-0075 Shinagawa HEART 1-8-23 Konan, Minato-ku, Tokyo**

- Please note that we are not responsible for the effects of the operation of the circuits, technologies, and programs covered in this document.
- When using the board, please also use the latest materials from each device manufacturer.



## 2. For Ensuring Safe Use



Be sure to follow the instructions given in this Manual which are intended to prevent harm to the user and others as well as material damage.

### 2.1. Legend

 <b>Danger</b>	Indicates an imminent hazardous situation which if not avoided will result in death or serious injury.
 <b>Warning</b>	Indicates a potentially hazardous situation which if not avoided could result in death or serious injury.
 <b>Caution</b>	Indicates a potentially hazardous situation which if not avoided may result in minor or moderate injury or in property damage.

### 2.2. Cautions

 <b>Danger</b>	<p>If an AC adapter is needed, be sure to use the AC adapter provided in the package or one that meets the specifications described in this manual.</p> <p>Using an AC adapter not meeting the specifications described in this manual may cause the card to emit heat, explode, or ignite.</p>
 <b>Warning</b>	<p>Do not apply strong impacts or blows to the card.</p> <p>Doing so may cause the card to emit heat, explode, or ignite, or the equipment in the card to fail or malfunction. This may also cause fire.</p>
	<p>Do not put this card or the AC adapter in cooking appliances such as microwave ovens, or high-pressure containers. Doing so might cause this card or AC adapter to emit heat, explode, ignite, or emit smoke, or its parts to break or warp.</p>
	<p>Do not cover or wrap this card that is in use with cloth or other materials that are likely to allow heat to build up inside the wrapping.</p> <p>This will cause heat to build up inside the wrapping which may cause this card to ignite or malfunction.</p>
	<p>When disposing of this card, do not dispose of it along with general household waste.</p> <p>Throwing this card into fire may cause it to explode. Dispose of this card following the laws, regulations, and ordinances governing waste disposal.</p>
	<p>Do not pull the power supply cable with excessive force or place heavy items on it. Do not damage, break, bundle, or tamper with the power supply cable.</p> <p>Damaged parts of the power supply cable might cause a short circuit resulting in fire or accidents involving electrical shock.</p>
 <b>Warning</b> (Continued from previous page)	<p>Do not plug or unplug the power plug with wet or moist hands.</p> <p>This might cause injuries or equipment malfunctions or failures due to electrical shock.</p>
	<p>Plug the power plug securely into the outlet.</p> <p>If the power plug is not securely plugged into the outlet, it may cause accidents involving electrical shock or fire due to heat emitted.</p>
	<p>Do not connect many electrical cords to a single socket or connect an AC adapter to an outlet that is not rated for the specified voltage.</p> <p>Doing so may cause the equipment to malfunction or fail, or lead to accidents involving electrical shock or fire due to heat emitted.</p>

	<p>Periodically remove any dust accumulated on the power plug and around the outlet (socket). Do not use a power plug with dust accumulated on it because doing so will lead to insulation failure due to moisture which may lead to fire. Remove any dust on the power plug and around the outlet with a dry cloth.</p> <p>Do not place any containers, such as cups or vases, filled with water or other liquids on the card. If the card is exposed to water or other liquids, it will cause a malfunction or electric shock. If you spilled water or other liquid on this card, immediately stop using the card, turn off the power, and unplug the power plug. If you have any requests for repairs or technical consultation, please contact the sales office you purchased or Mpression inquiry URL.</p> <p>Keep the card and accessories out of the reach of children. Failure to do so may lead to injuries.</p>
 <p><b>Caution</b></p>	<p>Do not place the card on unstable places such as shaky stands or tilted locations. Doing so may cause injuries or cause this card to malfunction if the card should fall.</p> <p>Do not attempt to use or leave the card in places subject to strong direct sunlight or other places subject to high temperatures such as in cars in hot weather. Doing so might cause the card to emit heat, break, ignite, run out of control, warp, or malfunction. Also, some parts of the equipment might emit heat, causing burn injuries.</p> <p>Do not use the card in places subject to extremely high or low temperatures or severe temperature changes. Doing so may cause the card to fail or to malfunction. Always be sure to use the card within a temperature range of 5°C to 35°C and a humidity range of 0% to 85%.</p> <p>Unplug the power supply when doing maintenance on equipment in which the card is embedded. Failure to do so may lead to accidents involving electrical shock.</p> <p>Do not place the card in locations where excessive force might be applied to it. Doing so may cause the printed circuit board to warp, leading to breakage of the printed circuit board, missing parts or malfunctioning parts.</p>
 <p><b>Caution</b> (Continued from previous page)</p>	<p>When using the card together with expansion boards or other peripheral equipment, be sure to carefully read each of their manuals and to use them correctly. Developer does not guarantee the operation of specific expansion boards or peripheral devices when used in conjunction with this card unless they are specifically mentioned in this Manual or their successful operation with this card has been confirmed in separate documents.</p> <p>Turn off the power switch when moving or connecting the card. Failure to do so may cause this card to fail or lead to accidents involving electrical shock.</p> <p>Do not clean this card by using a rag containing chemicals such as benzine or thinner. Doing so could degrade the card. When using a chemically treated cloth, comply with its directions and warnings.</p>

	<p>Do not immediately turn on the power if you find that moisture has condensed onto this card after removing it from the box.</p> <p>Condensation may form if the card is cold when moved from the box into a warm room.</p> <p>Turning on the power while there is moisture on the card may cause it to malfunction or shorten the service life of the parts.</p> <p>Allow the card to reach room temperature when you first take it out of the box. If condensation or moisture has occurred on this card, first wait for the moisture to fully evaporate before installing or connecting the card to other equipment.</p>
	<p>Operation of the card cannot be guaranteed if it has been disassembled, dismantled, altered, modified, or rebuilt.</p>

### 3. Please check when opening

Please check whether each package is included at the time of opening the package and whether it is damaged.

If the packaging is missing or you find visually recognizable damage, please contact your local sales representative within 30 days of delivery.

Table 3-1 List of Packing Items

Double pulse Evaluation Board : 1 sheet	
Spacers : 8	
Screws : 8	
Capacitor samples for snubber circuits (2kV / 68pF, 100pF, 220pF, 470pF, 680pF, 1000pF)	
Packing items and precautions	
Reference Manual	Please download these files from the URL described in "Packing List and Precautions".
Schematic	
BOM List	
PCB layout	



## 4. Functions and features of this board

### 4.1. Main features

The board is designed for the purpose of performing the common double-pulse evaluation in the evaluation of power switching devices such as SiC FETs. It consists of a half-bridge circuit and is equipped with the gate drivers and power supply circuits. It is also compatible with various probes and current sensors.

- Supports double pulse evaluation up to 1700V and 150A
- Prepared through-holes compatible with TO-247-4L and TO-247-3L
- Single +12V supply operation
- Equipped with adjustable gate drive isolated power supply (~25V/Zener diode selected)
- Zero volt bias or negative volt bias can be set with jumper
- Miller clamp with built-in driver IC
- VDS and VGS probing equipped with connectors and probe contacts for optically isolated probes
- CT, coaxial shunt resistor, and Rogowski coil can be used for current sensors.

The board is designed specifically for double pulse evaluation. Continuous energization is not envisaged.

### 4.2. Board Specifications

Fig. 4.2-1 and 2 show the appearance of the double pulse evaluation board, and Table 4.2-1 shows the dimensions and weight.

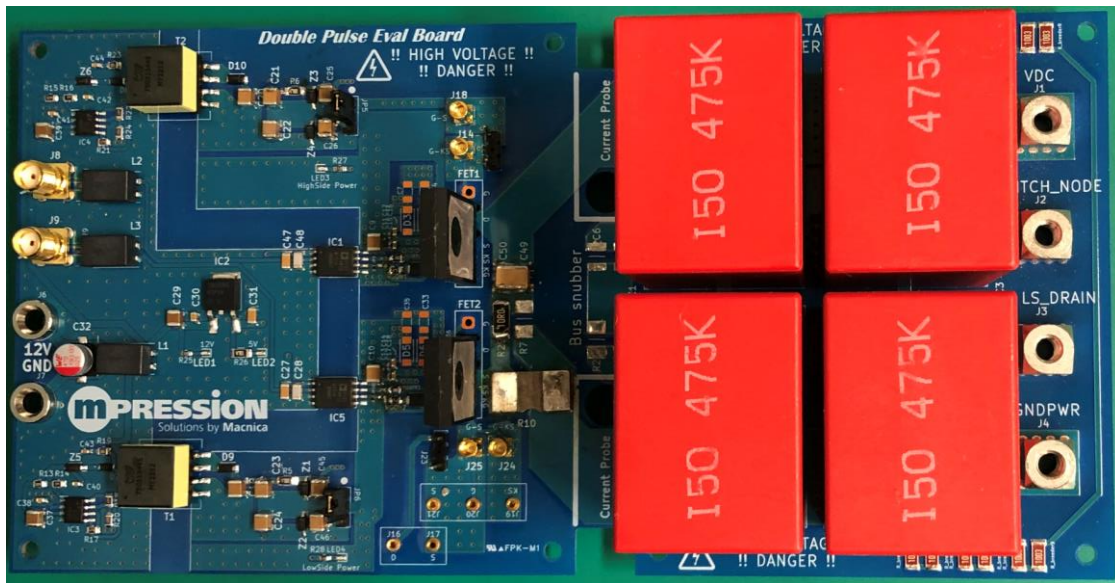

Figure 4.2-1 Appearance Table

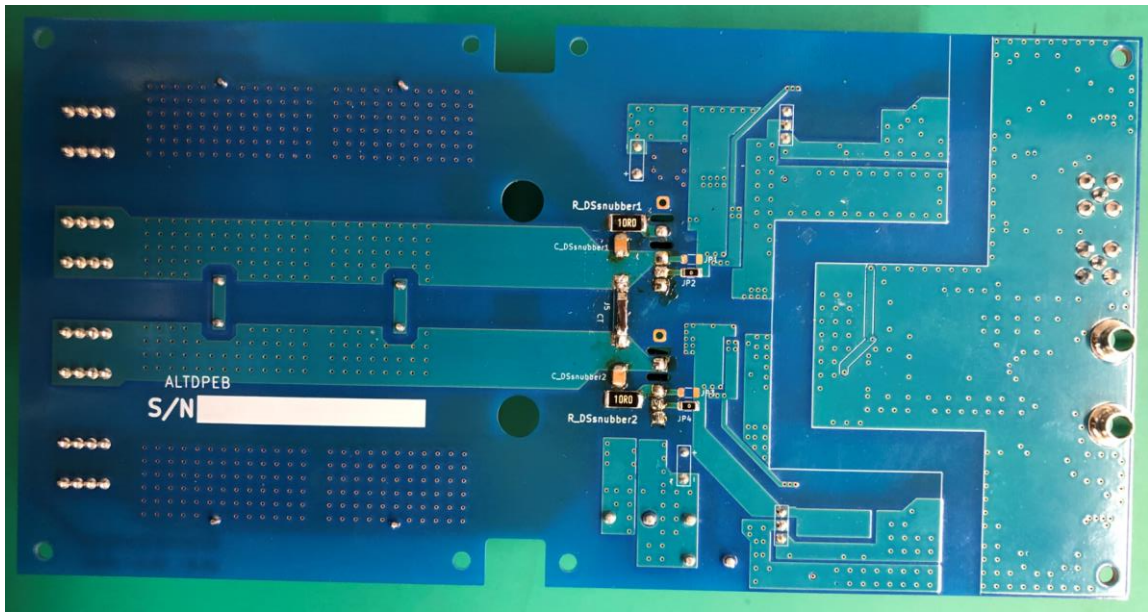

Figure 4.2-2 Exterior Back

Table 4.2-1 Dimensions and Weight

Length	211.6	mm
Width	106.2	



Table 4.3-1 Functional Details of Blocks

Function	Detail
Gate Driver	Gate Drive IC (ADuM4121)
Isolated Power supply	Gate Drive Power Supply IC (LT8302)
Gate resistance	Adjustment circuit for adjusting FET switching speed (turn-on and turn-off)
Low Drop Out regulator	Power supply for control circuits. Power supply for control circuits of logic level input signals
Bus Capacitor	Smoothing capacitors in VDC lines
Bus snubber	VDC Bus Snubber
DS Snubber	RC snubber circuit connected to the upper and lower arms, respectively
Gate Protection	Surge voltage protection circuit between gate and source. Clamping positive and negative surges with Schottky barrier diodes
Breeder Resistance	VDC discharge resistance (100 kΩ×14 series) When VDC = OFF, discharge the charge of the capacitor on the VDC line
Negative Bias select	GNDA/B voltage setting. 0V/negative voltage is selected by setting pin.

## 4.4. Electrical characteristics

Table 4.4-1 lists the maximum ratings and Table 4.4-2 lists the recommended operating conditions.

Table 4.4-1 Maximum Ratings

Item	Symbol	Min	Max	Unit	Annotation
Input High Voltage DC	VDC		1700	V	Compliant with VDC line capacitors
Supply Voltage	12V_IN		25	V	
Input Signal Voltage	VIA, VIB	-0.3	7	V	ADuM4121
Storage Temperature	T <sub>STG</sub>	-10	85	°C	

Table 4.4-2 Recommended Operating Conditions

Item	Symbol	Min	Typ	Max	Unit	Annotation
Input High Voltage DC	VDC			1700	V	
Supply Voltage	12V_IN	10.8	12	13.2	V	
Double Pulse Current	IDP			150	A	
Gate positive supplied voltage	VDDA, VDDB		15		V	See 5.3.1 Depend on Diode
Gate negative supplied voltage	VGND A, VGND B		-4.7		V	See 5.3.2 Depend on Diode
Input signal Low level voltage	V <sub>IL</sub>			1.5	V	
Input signal High Level voltage	V <sub>IH</sub>	3.5			V	
Operating Temperature	Top	-10		85	°C	

## 5. Components of this board

### 5.1. LED display

Each LED (red) is implemented to check each operating status of the board.

Figure 5.1-1 shows where each LED is mounted, and Table 5.1-1 shows details.

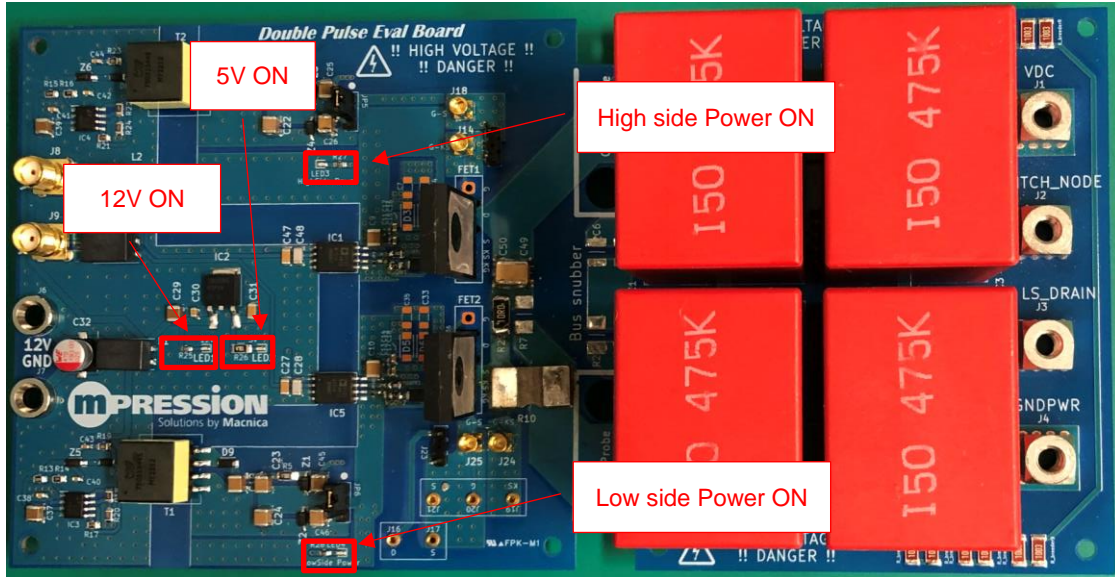

Figure 5.1-1 LED mounting location

Table 5.1-1 Description of Each LED Lighting

Silk notation	LED	Detail
12V LED1	red	Power supply for control. 12 V output when on, no output when off
5V LED2	orange	Power supply for control. 5V output when on, no output when off
High side Power LED3	green	Isolated power supply for high side gate drive. Output when the light is on, not when the light is off
Low side Power LED 4	green	Isolated power supply for low-side gate drive. Output when the light is on, not when the light is off

## 5.2. Connector Pin Assignment

Figure 5.2-1 describes each connector, and Table 5.2-1 describes power supply pins and signal pins.

J1 (VDC) is a terminal for applying high voltage, and J4 (GNDPWR) is a power GND terminal when applying high voltage. Connect the + side of the power supply to J1 and the - side of the power supply to J4. Power GND and input signal side GND are completely isolated. J2 (SWITCH\_NODE) becomes the source terminal for the High side MOSFET, so connect an inductor to J1 and J2 when performing the Low side FET double pulse evaluation. J3 (SWITCH\_NODE) becomes the drain terminal for the Low side FET, so connect an inductor to J3 and J4 when performing the High side FET double pulse evaluation.

For more information, see "6.5. Double Pulse Evaluation Procedure".

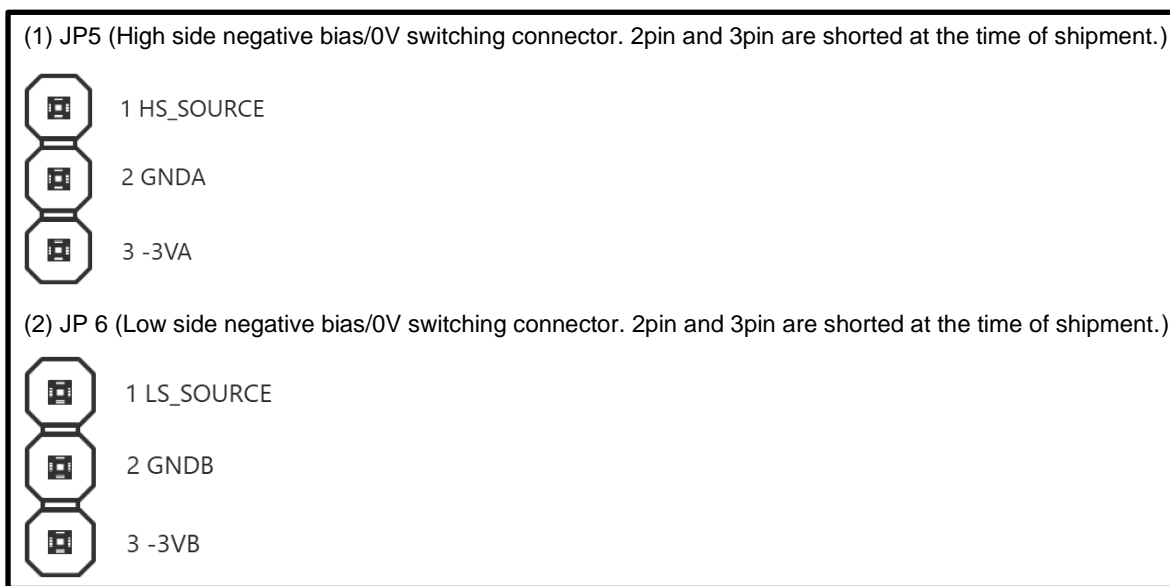

Figure 5.2-1 Pinout for Each Connector

Table 5.2-1 Power Supply and Signal Pin Descriptions

Pin	Signal	Detail
J1	VDC	High-side FET drain terminal
J2	SWITCH_NODE	High side FET source terminal
J3	LS_DRAIN	Low-side FET drain terminal
J4	GNDPWR	Power GND terminal Not connected to SGND on the input signal side
CN1	VIA (PIN 1)	High side FET ON/OFF signal Turns on at “H” input
CN1	GND_SMA_A (PIN 2-5)	When open, it is pulled down by a 10kΩ resistor.
CN101	VIB(PIN 1)	GND on the input signal side Completely separated from GND on the high-voltage side
CN101	GND_SMA_B (PIN 2-5)	Low side FET ON/OFF signal Turns on at “H” input
J6	12V_AUX	Used as a power supply for control
J7	GND_AUX	GND on the input signal side Completely separated from GND on the high-voltage side



### 5.3. Power supply circuit for gate drive

The voltage for gate drive comes from an isolated flyback supply mounted on the board. Analog Device's IC (LT8302ES8E) and transformer output about 25V, and a Zener diode generates positive and negative voltages on the High side and Low side. VDDA and VDDB are positively biased to cause the FET to ON, HS\_SOURCE, LS\_SOURCE is a zero bias that causes the FET to OFF, and -3VA and -3VB are negative biases.

\* Be sure to energize JP5 and JP6 with the jumper attached.

Figure 5.3-1 shows the layout of the gate drive power supply on the board.

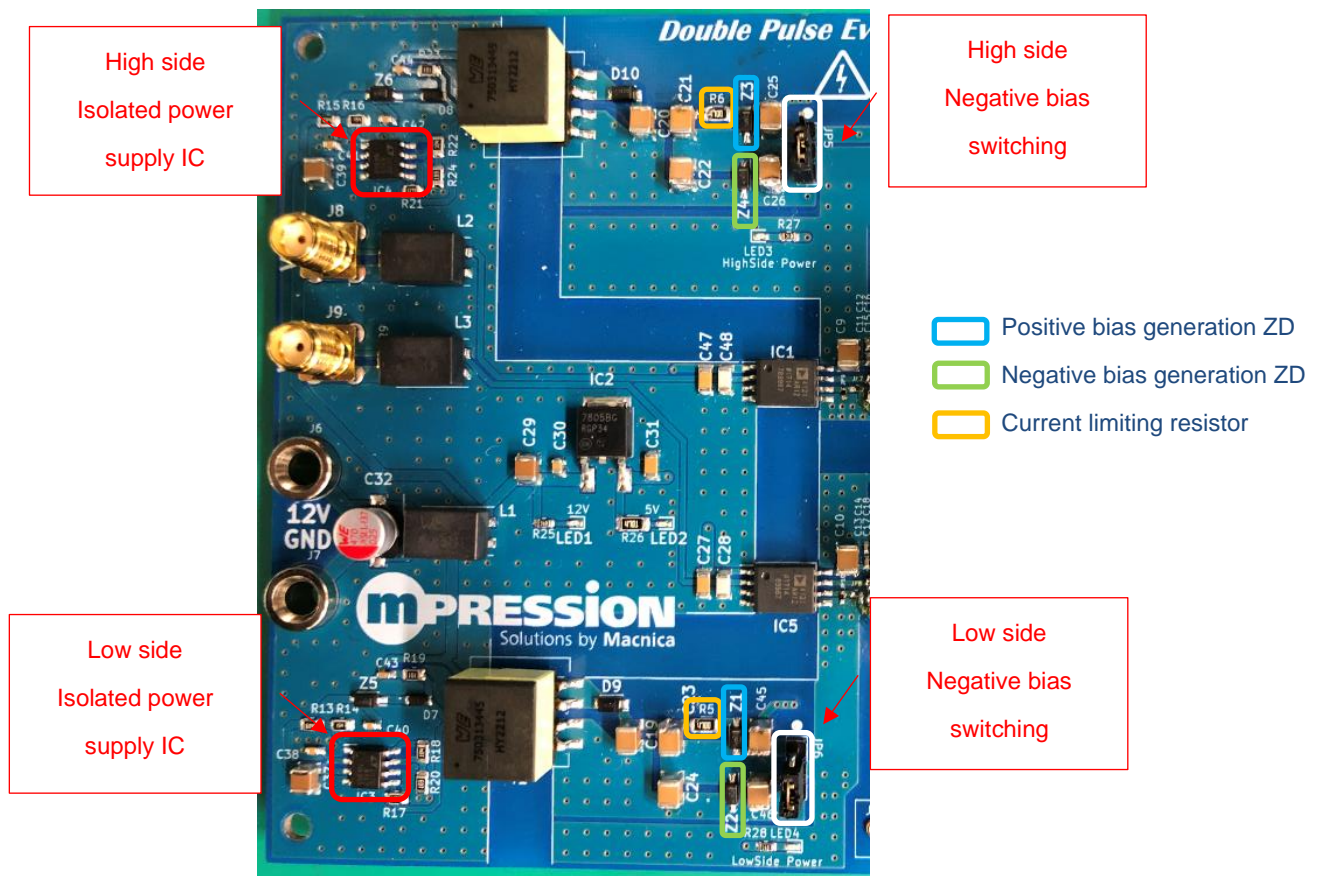

Figure 5.3-1 Gate Power Supply Configuration

#### 5.3.1. How to adjust for positive bias

The positive, negative, and zero bias voltages are generated by series and clamping two Zener diodes on the secondary side of an isolated flyback power transformer. The positive bias initially outputs 15V between VDDA- HS\_SOURCE, but the positive bias voltage can be adjusted by changing this Zener diode (break voltage). Current-limiting resistors inserted in series may also need to be adjusted.

### 5.3.2. How to adjust for negative bias

The bias voltage to turn off the FET can be selected as 0V bias or negative bias by switching the JP5 (High side) and JP6 (Low side) pins. In addition, the voltage of the negative bias can be adjusted by changing the Zener diode in the same way as the " How to adjust for positive bias " above.

## 5.4. Gate drive circuit

The board has a gate resistor implemented to regulate the switching speed of the FET. Diodes (D1, D2) are connected to this gate line, and it is possible to adjust the turn-on and turn-off switching speeds.

High side gate resistance: RGON1 // RGOFF1 at turn-on, RGOFF1 as turn-off

Low side gate resistance: RGON2 // RGOFF2 at turn-on, RGOFF2 at turn-off

For the mounting position and schematic location of each gate drive circuit on the board, see Figure 5.4-1 and Figure 5.4-2. Analog device isolated gate driver IC (ADuM4121) drives the FET from the output (VOUT) pin through the gate resistor. Also, when using a 4-pin device and a 3-pin device, the insertion point is different, and the jumper for connecting the source must also be replaced. Please refer to Figure 5.4-1 before use.

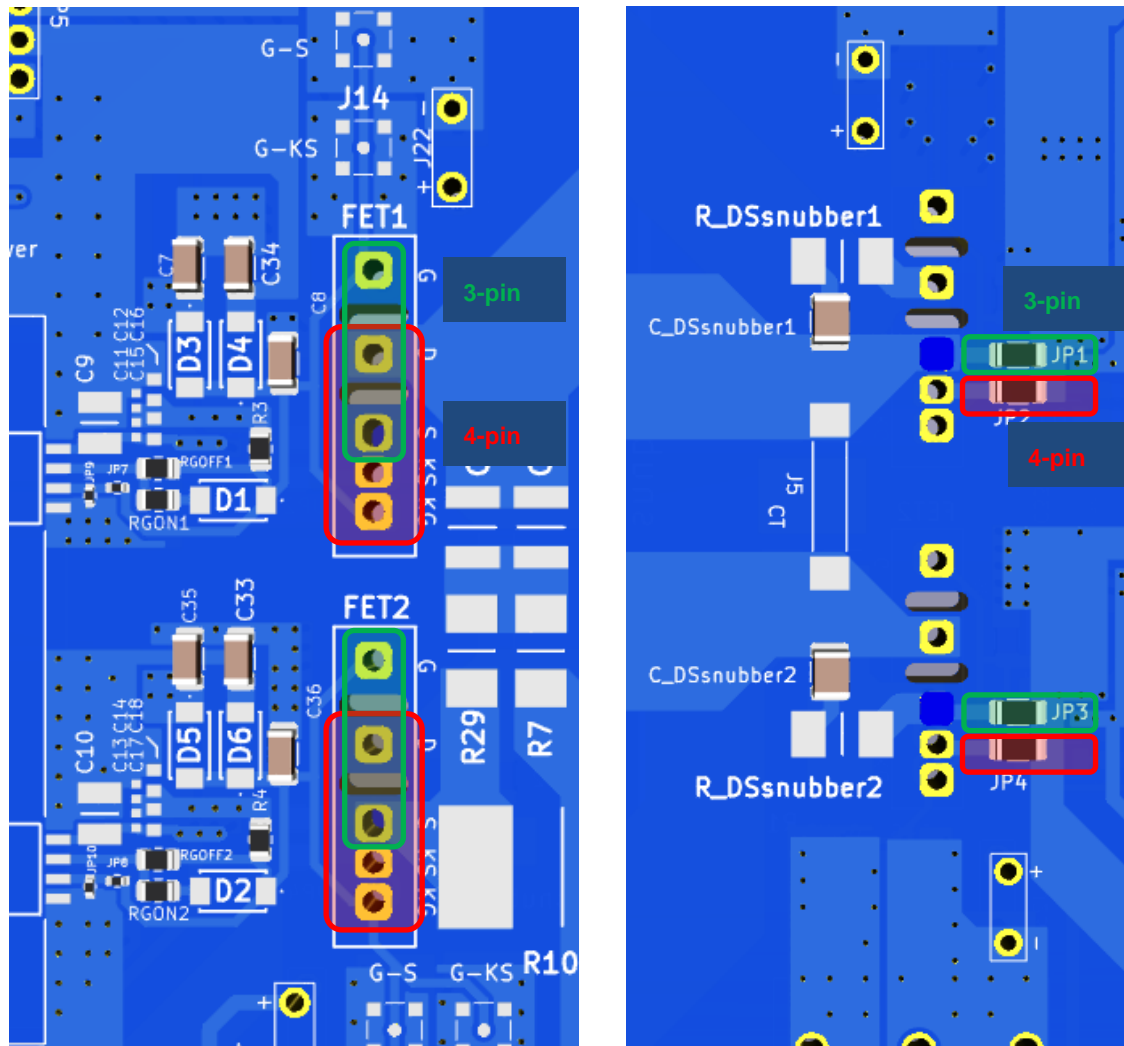

Figure 5.4-1 Board mounting position around the gate drive circuit

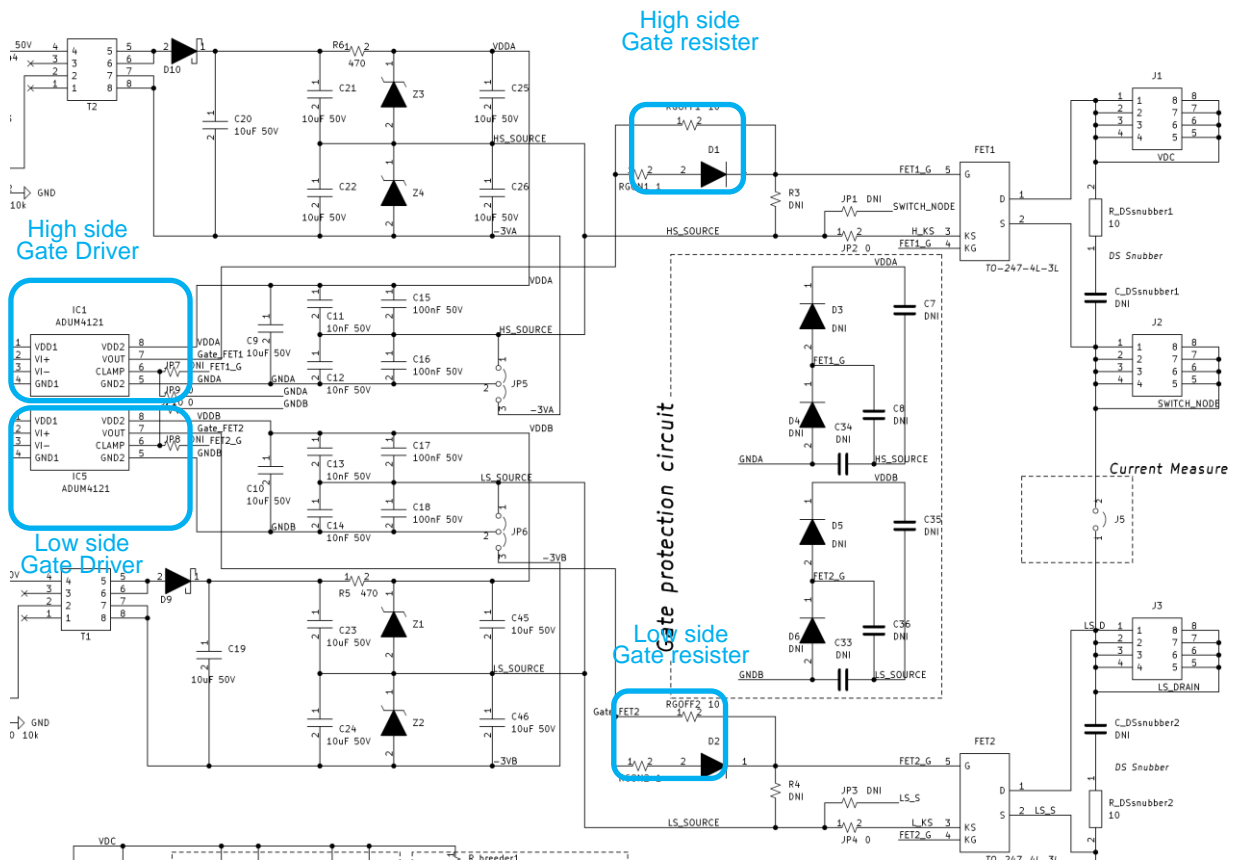

Figure 5.4-2. Gate drive circuit

## 5.5. Snubber circuit

### 5.5.1. RC Device Snubber

An RC snubber circuit is implemented between the FET drain and source. This circuit has the effect of suppressing surges during FET turn-off, but please note that manufacturer's recommendations vary from device to device. For mounting positions and schematic positions, refer to Fig. 5.5.1.

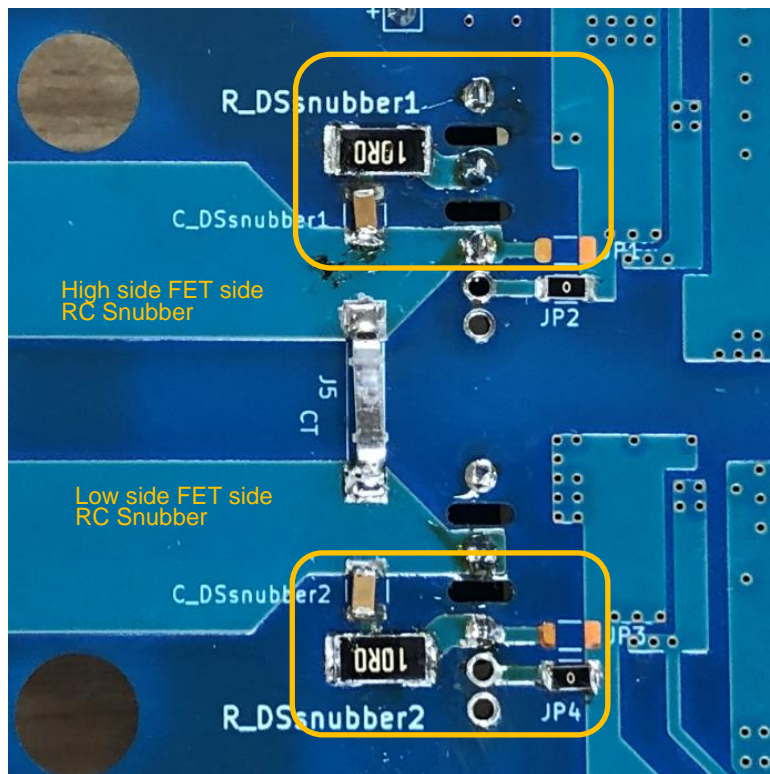
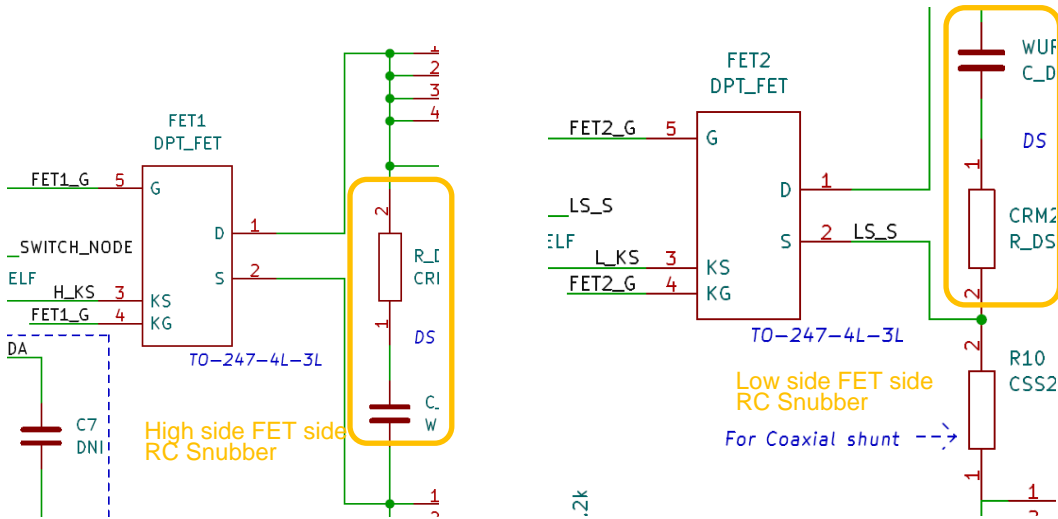

Figure 5.5.1 Mounting position of RC device snubber





## 6. Device measurement methods

### 6.1. VDS, VGS measurement

The board has multiple connectors for High side FETs and Low side FETs respectively to allow VDS and VGS measurements.

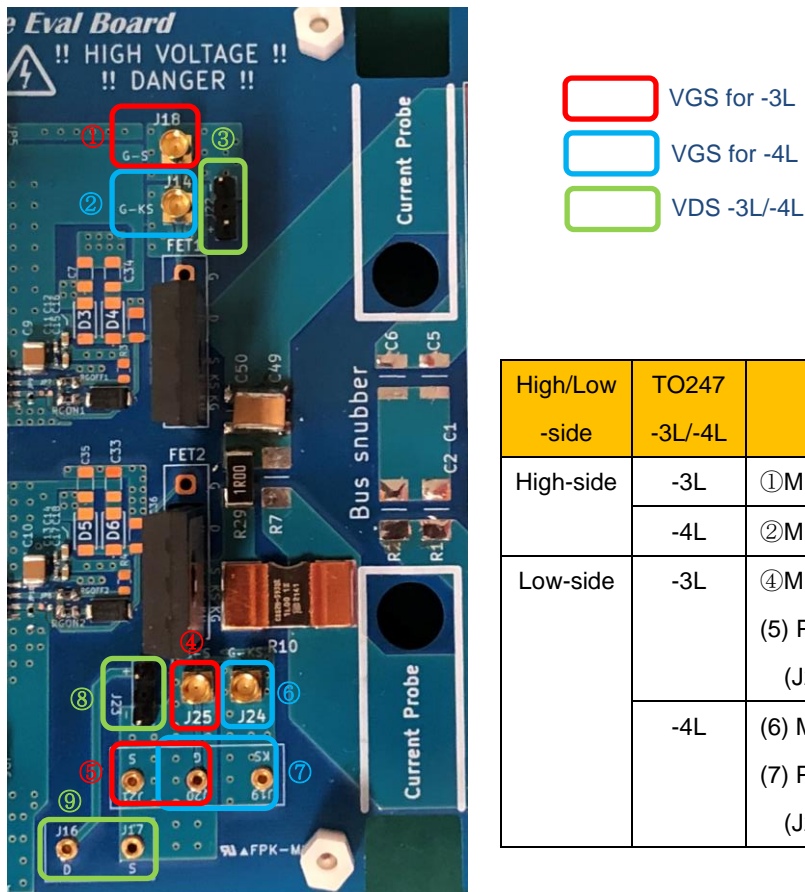

High/Low -side	TO247 -3L/-4L	VGS	VDS
High-side	-3L	①MMCX(J18)	(3) Pin header (J22)
	-4L	②MMCX(J14)	
Low-side	-3L	④MMCX(J25) (5) Probe contact (J20-J21)	(8) Pin header (J23) (9) Probe contact (J16-J17)
	-4L	(6) MMCX(J24) (7) Probe Contact (J20-J19)	

Figure 6.1-1 VGS, VDS measurement connector

## 6.2. Current measurement with C T

CT can be used to measure the source current of the High side FET and the drain current of the Low side FET. The measurement point is J5 on the back of the board. It is practical to insert a transformer with a compact winding ratio of about 10: 1, reduce the current value, and then measure it with CT.

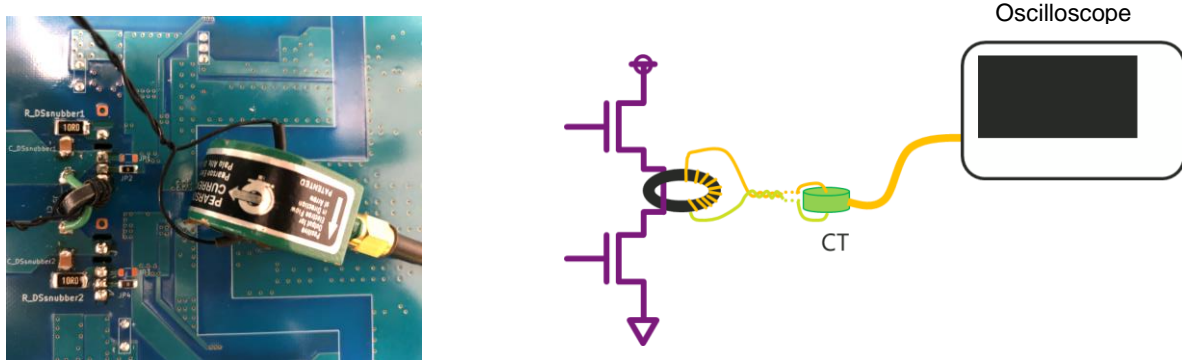

Figure 6.2-1 Example of measurement of ferrite toroidal core with 10:1 transformer and CT (Pearson 2877)

When measuring with CT, pay attention to the connection position of the coil.

## 6.3. Measurement with a Rogowski current probe

The board has through-holes on the High side and Low side and slits at the edges of the board. The Rogowski current probe can be used to measure the drain current of the High side FET and the source current of the Low side FET. When measuring with a Rogowski current probe, the mounting position of the bus snubber should be in front of the probe insertion path (R1, R2, C5, C6) so that the current of the bus snubber is not measured together.

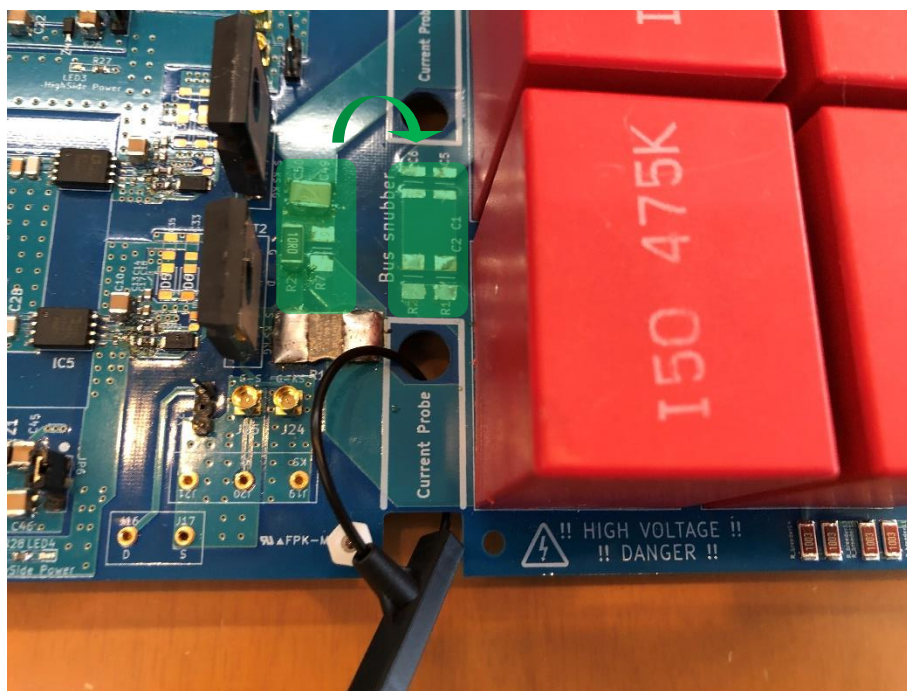

Figure 6.3.1 Example of connecting the TRCP0300 to LowSide. The same goes for HighSide.



## 6.4. Measurement with coaxial shunt resistors

A coaxial shunt resistor can be used to measure the source current of the Low side FET. See Figure 6.4.1 for mounting positions. When using a general passive probe together, connect the GND terminal of the coaxial type shunt resistor to the source potential of the FET in order to prevent GND level mismatch on the oscilloscope.



Figure 6.4-1 Measurement method with coaxial shunt resistor

## 6.5. Double Pulse Evaluation Procedure

Figure 6.5-1 shows the connections for VDS and ID measurements by switching low-side FETs.

Connect the control supply +12V to the 12V\_AUX pin (J6) and GND to the GND\_AUX (J7) pin. Connect the signal output of the pulse generator to the VIB pin (J9). Connect the high-voltage power supply to the VDC pin (J1) and GND to the GNDPWR pin (J4).

The operation procedure is as follows. (For Low Side switching)

1. Set jumpers JP5, JP6 to zero bias or negative bias
  - If it is open, a large current may flow through the FET when VDC (high voltage) is inserted, and it may be damaged.
2. Power up +12V and verify LED1, LED2, LED3, and LED4 are lit.
3. Input a double pulse to VIB from the pulse generator to verify that the gate potential of each FET is as expected
4. Turn on the VDC (high voltage) power supply
5. Input a double pulse from the pulse generator to observe and measure voltage and current waveforms.
6. Shut down the +12V supply
  - Never touch the board until the main capacitor is discharged.

The coil connection position according to the measurement parameters is shown in Figure 6.5-2. To switch the high-side FET, connect it to the pulse generator output VIA (J8).

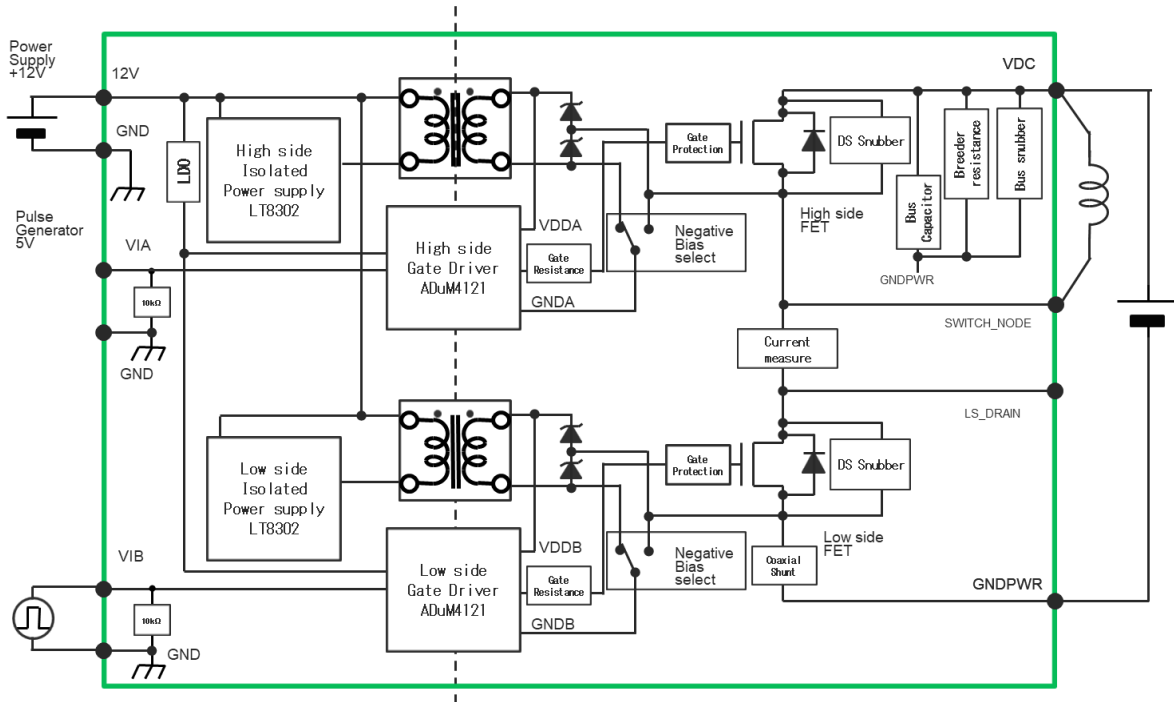

Figure 6.5-1 Low side FET double pulse measurement circuit

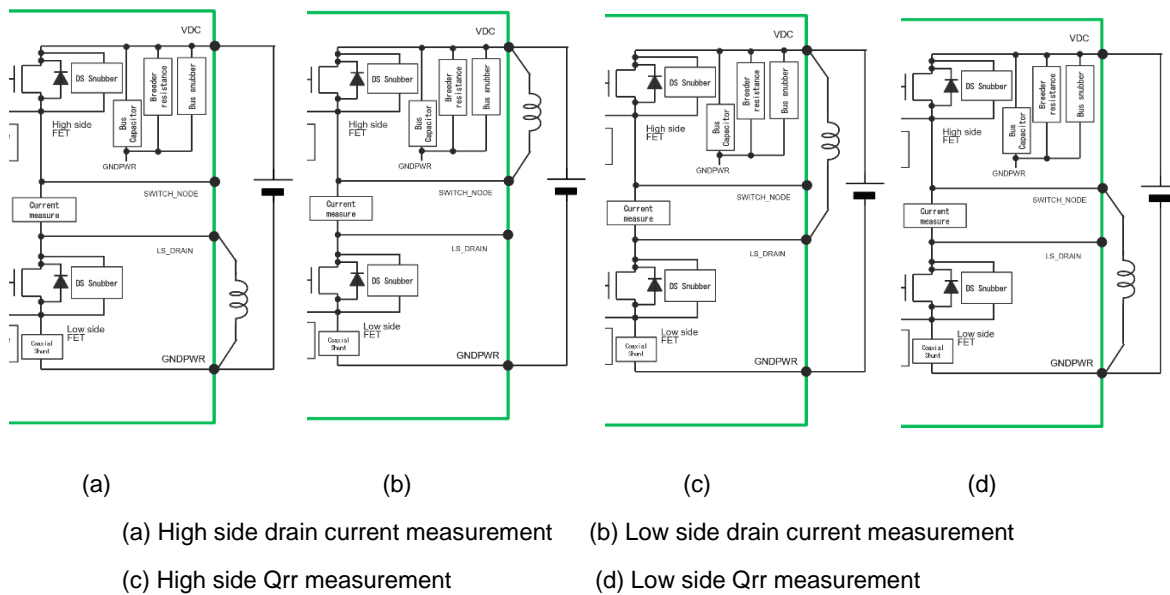

Fig. 6.5-2 Connection position between measurement items and coil