

Description

The AM4962 is a full wave driver IC with direct PWM control function. It is used for single-phase motor and is capable of speed control by PWM pulse.

The AM4962 is available in HTSSOP-14 and SSOP-16 packages.

Features

- The Motor Speed is Controlled by PWM Pulse Directly
- Built-in Triangle Wave Circuit Without Extra Oscillation Capacitor
- Built-in Hall Bias Circuit
- Built-in Minimal Speed Setup Circuit
- Slope K* Adjustable
- Rotation Speed Indication (FG)
- Rotation or Lock State Indication (RD)
- Built-in Thermal Shutdown Circuit
- Lock Protection and Auto-Restart
- Output Current Limit

* Slope K is the slope of output PWM duty vs. input PWM duty

Applications

- CPU Cooler Fan in PC
- Brushless DC Motor Driver

Pin Assignments

(Top View)

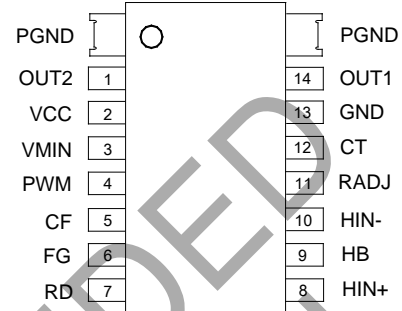

HTSSOP-14

(Top View)

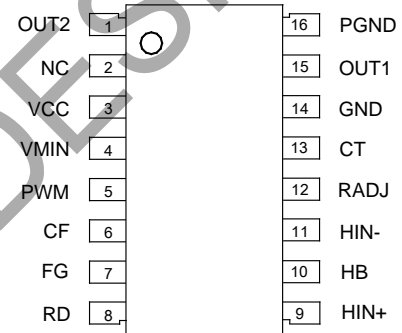

SSOP-16

Typical Applications Circuit (Note 1)

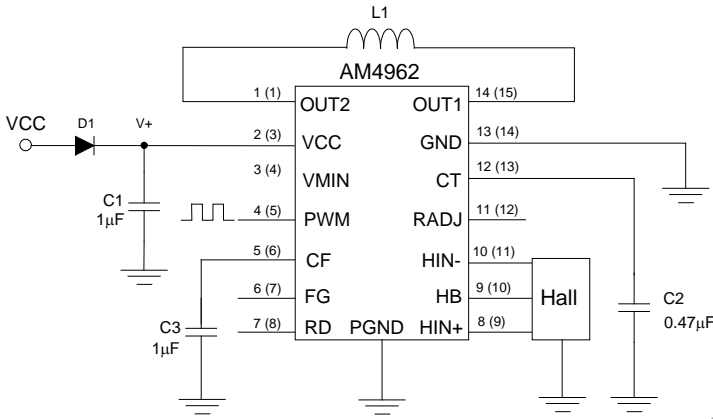

Application 1 (Default)

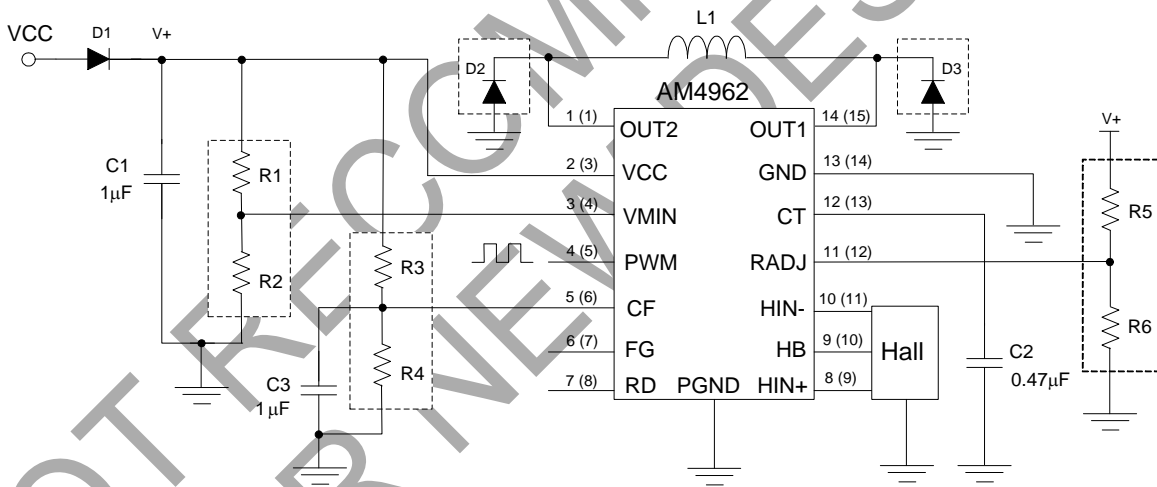
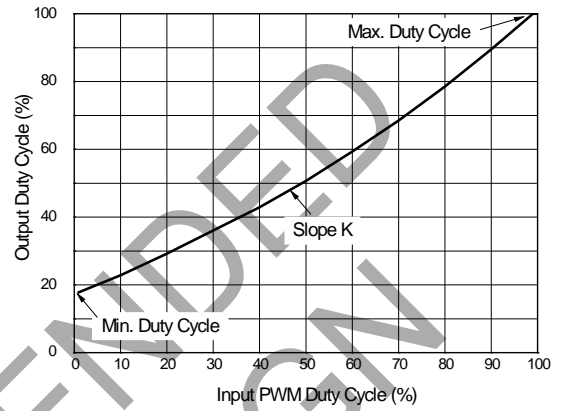

Application 2 (Slope K and Minimum/Maximum Duty Adjustable)

Note: D2 and D3 are recommended to be used when the current in coil L1 is higher than 300mA.

Typical Applications Circuit (Note 1) (Continued)

Note 1 (Refer to application circuit 2 unless otherwise noted.):

Adjust slope K of output PWM's duty vs. input PWM's duty

1. The default K is about 0.8
2. Adding R5 can increase K
3. Adding R6 can decrease K

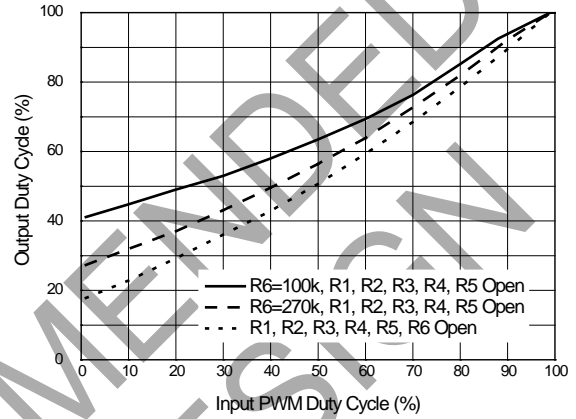
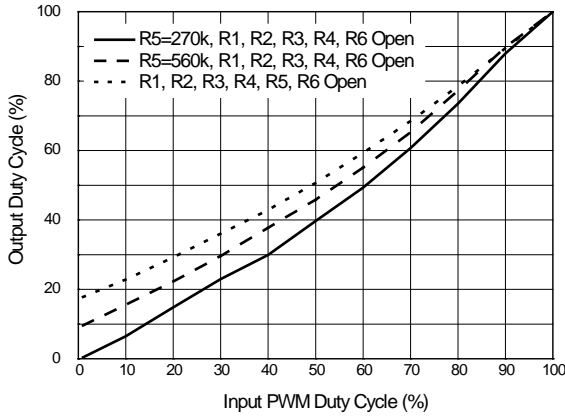

Adjust minimum duty of output PWM:

1. The default minimum duty of output PWM is about 20%
2. Decreasing R2 can increase minimum output PWM duty
3. Adding R5 can decrease minimum output PWM duty

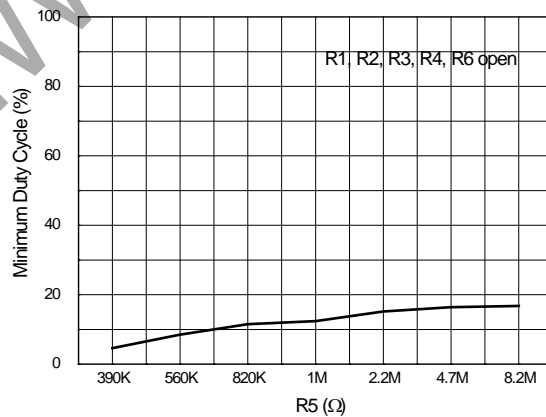
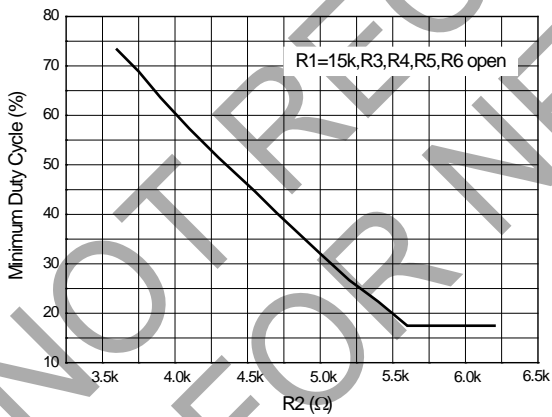

Typical Applications Circuit (Note 1) (Continued)

Adjust maximum duty of output PWM:

1. The default maximum output PWM duty is 100%.
2. Adding R3 can decrease maximum output PWM duty.
3. Adding R4 can increase maximum output PWM duty.

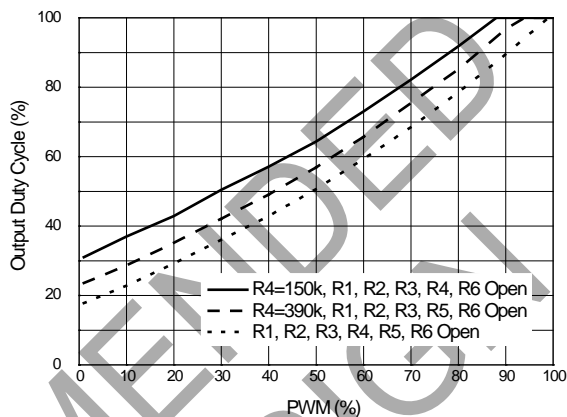
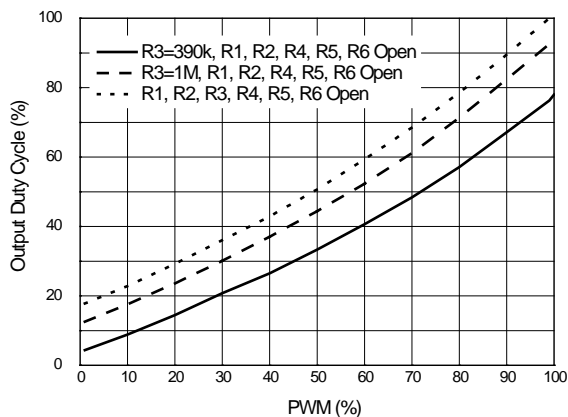

Pin Descriptions

Pin Number		Pin Name	Function
HTSSOP-14	SSOP-16		
1	1	OUT2	Driver output 2
—	2	NC	No connection
2	3	VCC	Power supply
3	4	VMIN	Minimum duty setting
4	5	PWM	PWM pulse Input
5	6	CF	PWM filter capacitor
6	7	FG	Rotation speed indicator
7	8	RD	Rotation/lock state indicator
8	9	HIN+	Hall sensor input +
9	10	HB	Hall sensor bias regulator
10	11	HIN-	Hall sensor input -
11	12	RADJ	Slope K adjustable terminal
12	13	CT	Lock and rotation setting capacitor terminal
13	14	GND	Ground for control circuit
14	15	OUT1	Driver output 1
—	16	PGND	Power ground

Functional Block Diagram

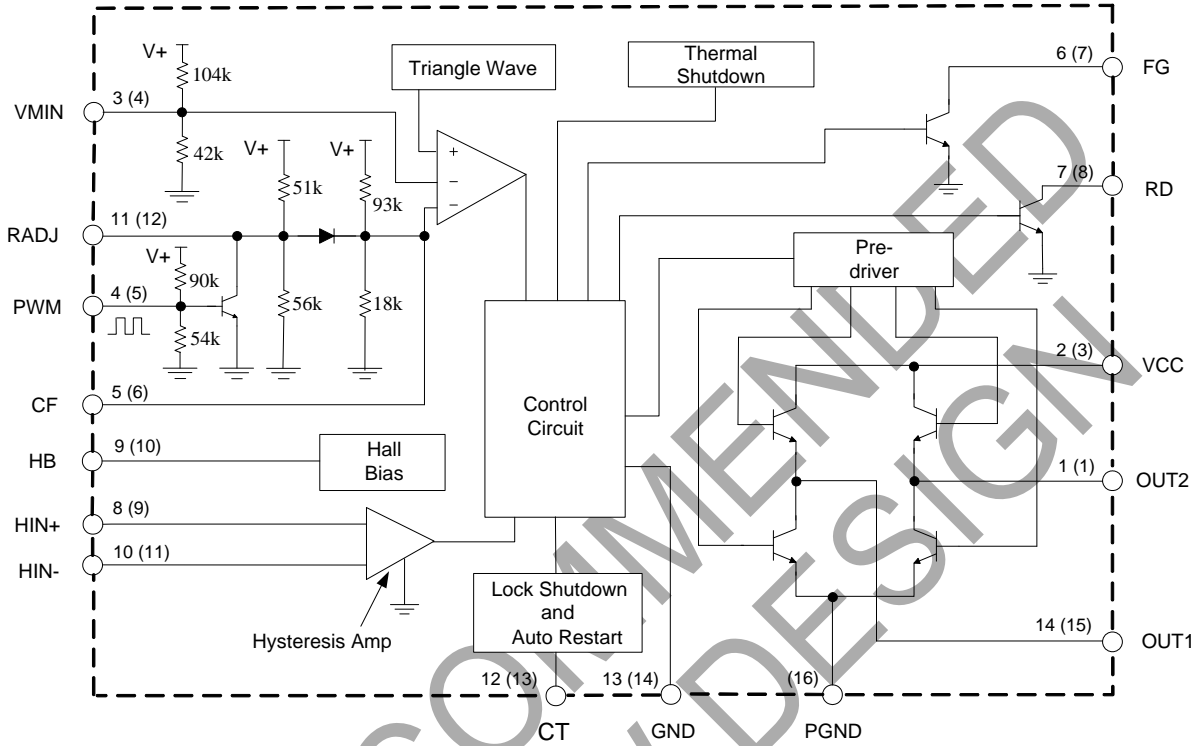

A (B)
A HTSSOP-14
B SSOP-16

Truth Table (Note 2)

Items	IN-	IN+	CF	CT	OUT1	OUT2	FG	Mode	
1	H	L	L	L	H	L	L	Rotation	
2	L	H			L	H	Off	Off	PWM off
3	H	L	H		L	Off	L	L	Rotation Recirculate
4	L	H				L	Off	Off	Off
5	H	L	L	H	H	Off	L	Lock Protection	
6	L	H			Off	H	Off		Off

Note 2: $V_{CF(H)}=5V$, $V_{CF(L)}=1V$, $V_{CT(H)}=5V$, $V_{CT(L)}=0$

Absolute Maximum Ratings (Note 3)

Symbol	Parameter	Value		Unit
V _{CC}	Supply Voltage	18		V
I _{OUT}	Output Current	1.0		A
V _{OUT}	Output Voltage	18		V
I _{HB}	HB Output Current	10		mA
V _{RD}	RD Output Voltage	18		V
V _{FG}	FG Output Voltage	18		V
I _{RD}	RD Output Current	10		mA
I _{FG}	FG Output Current	10		mA
P _D	Power Dissipation	SSOP-16	0.8	W
		HTSSOP-14	1.1	W
T _{STG}	Storage Temperature Range	-55 to +150		°C
θ _{JA}	Thermal Resistance (Junction to Ambient)	SSOP-16	156	°C/W
		HTSSOP-14	114	
ESD	ESD (Human Body Model)	2000		V
ESD	ESD (Machine Model)	250		V

Note 3: Stresses greater than those listed under "Absolute Maximum Ratings" may cause permanent damage to the device. These are stress ratings only, and functional operation of the device at these or any other conditions beyond those indicated under "Recommended Operating Conditions" is not implied. Exposure to "Absolute Maximum Ratings" for extended periods may affect device reliability.

Recommended Operating Conditions

Symbol	Parameter	Min	Typ	Max	Unit
V _{CC}	Supply Voltage	3.5	12	16	V
V _{IN+}	Hall Input Voltage + (Note 4)	0.2	—	3	V
V _{IN-}	Hall Input Voltage - (Note 4)	0.2	—	3	V
V _{PWM}	PWM High Level Voltage	—	—	V _{CC} -1	V
T _A	Ambient Temperature	-30	—	+90	°C

Note 4: Hall input voltage range includes the amplitude of signal.

Electrical Characteristics ($V_{CC}=12V$, $T_A=+25^{\circ}C$, unless otherwise specified.)

Symbol	Parameter	Conditions	Min	Typ	Max	Unit
I_{Q1}	Quiescent Current	$V_{CT}=0$	10.18	15	18.76	mA
I_{Q2}		$V_{CT}=5V$	5.38	8	10.55	
V_{SATH}	Output Saturation Voltage at High Side	$I_{SOURCE}=200mA$	—	1.0	1.17	V
V_{SATL}	Output Saturation Voltage at Low Side	$I_{SINK}=200mA$	—	0.2	0.3	V
f_{OSC}	CPWM Frequency	—	18	25	32	kHz
V_{CFH}	CF High Level Voltage	$V_{PWM}=0$	3.2	3.6	3.75	V
V_{CFL}	CF Low Level Voltage	$V_{PWM}=5$	1.83	1.95	2.15	V
V_{MIN}	VMIN Voltage	—	3.4	3.7	4.0	V
V_{ADJ}	RADJ Pin Voltage	$V_{PWM}=0$	3.6	3.8	4.4	V
V_{HYS}	Hall Input Hysteresis	—	—	± 10	± 20	mV
V_{HB}	Hall Bias Voltage	$I_{HB}=5mA$	1.1	1.25	1.4	V
V_{CTH}	CT High Level Voltage	—	3.55	3.7	3.88	V
V_{CTL}	CT Low Level Voltage	—	1.55	1.7	1.85	V
I_{CHG}	CT Charge Current	—	1.5	2	2.85	μA
I_{DHG}	CT Discharge Current	—	0.14	0.2	0.285	μA
R_{CD}	CT Charge and Discharge Ratio	I_{CHG}/I_{DHG}	8.5	10	14.5	—
V_{FGL}	FG Output Low Level Voltage	$I_{FG}=5mA$	—	0.2	0.3	V
I_{LFG}	FG Leakage Current	$V_{FG}=12V$	—	—	30	μA
V_{RD}	RD Output Low Level Voltage	$I_{RD}=5mA$	—	0.2	0.3	V
I_{LRD}	RD Leakage Current	$V_{RD}=12V$	—	—	30	μA

Performance Characteristics

Quiescent Current vs. Ambient Temperature

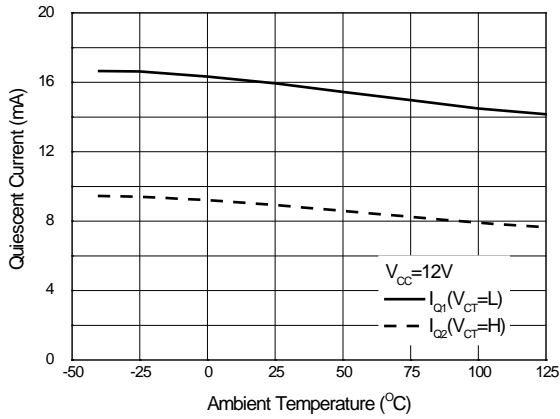

Quiescent Current vs. Supply Voltage

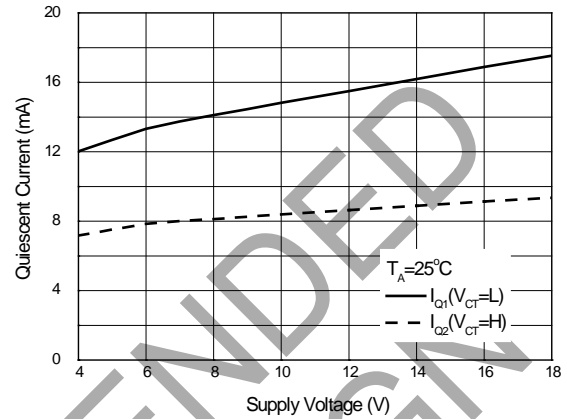

Output Saturation Voltage vs. Output Current

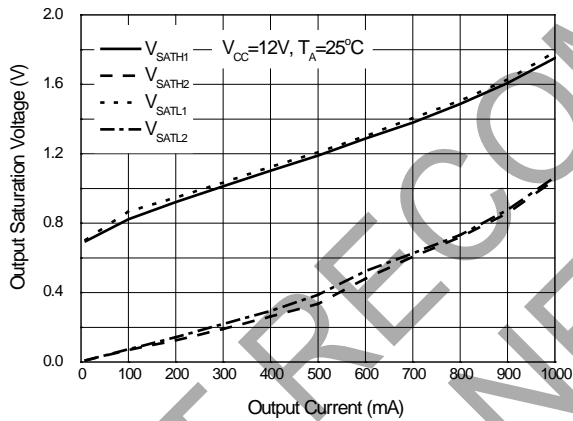

Power Dissipation vs. Ambient Temperature

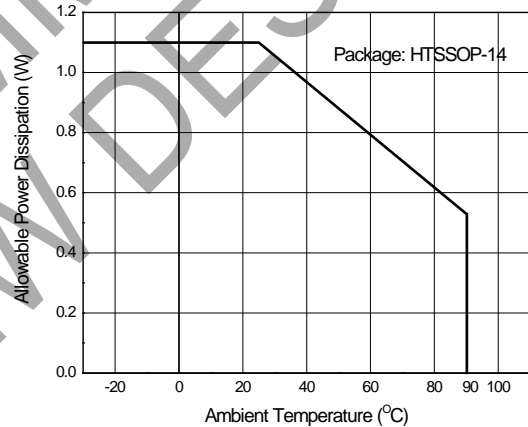

Power Dissipation vs. Ambient Temperature

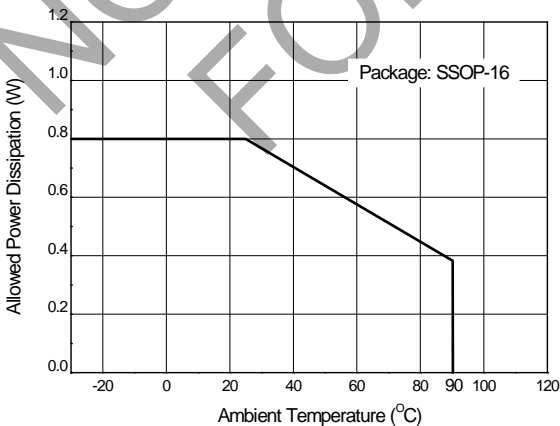

Operating Diagram

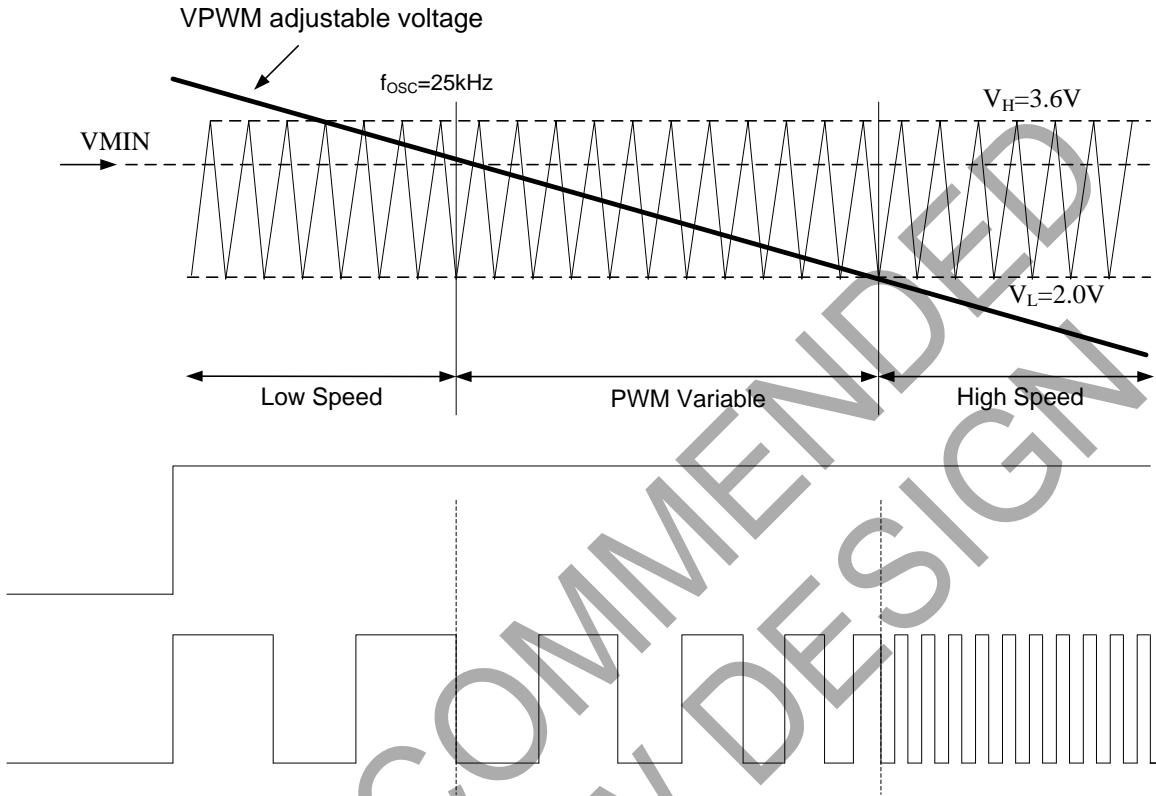

All parameters are tested under $V_{CC} = 12\text{V}$

NOT RECOMMENDED FOR NEW DESIGN

Ordering Information

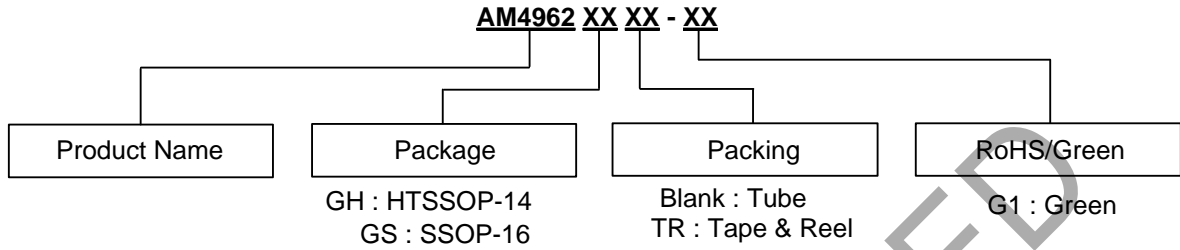

Package	Temperature Range	Part Number	Marking ID	Packing
HTSSOP-14	-30 to +90°C	AM4962GH-G1	AM4962GH-G1	Tube
		AM4962GHTR-G1	AM4962GH-G1	Tape & Reel
SSOP-16		AM4962GS-G1	AM4962GS-G1	Tube
		AM4962GSTR-G1	AM4962GS-G1	Tape & Reel

NOT RECOMMENDED FOR NEW DESIGN

