

# AM-123 / AMC-123



**High Performance Amplifier, 10 dB Gain**  
**5 - 500 MHz**

Rev. V6

## Features

- 3.5 dB Mid-band Noise Figure
- 42 dBm Mid-band Intercept

## Description

The AM-123 is a coupler feedback amplifier with high intercept and compression points. The use of coupler feedback minimizes noise figure and current in a high intercept amplifier. This amplifier is available in both the flat pack (FP-7) and the connectorized (C-32) packages. Due to the internal power dissipation the thermal rise is minimized. The ground plane on the PC board should be configured to remove heat from under the package.

AM-123 is ideally suited for use where a high intercept, high reliability amplifier is required.

## C-32

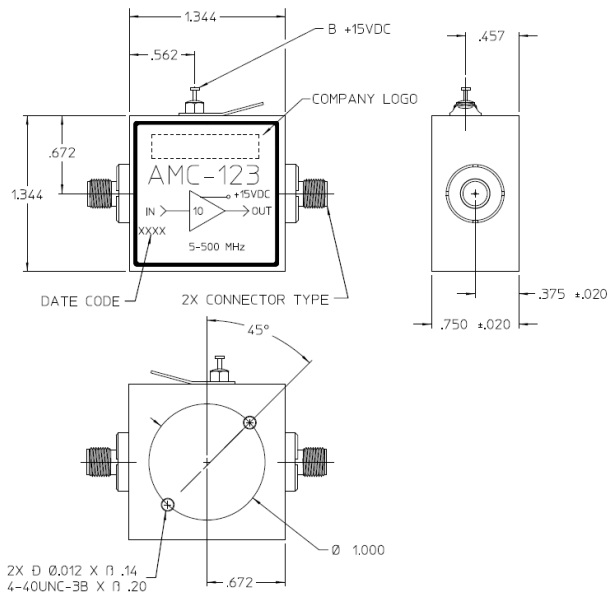

Dimensions are in mm unless otherwise noted.  
 .xxx = ±0.010 (.xx = ±0.85)  
 .xx = ±0.02 (.x = ±0.5)  
 AM-123 Positive voltage only.  
 Weight (approx.) 1.62 ounces, 46 grams

## FP-7

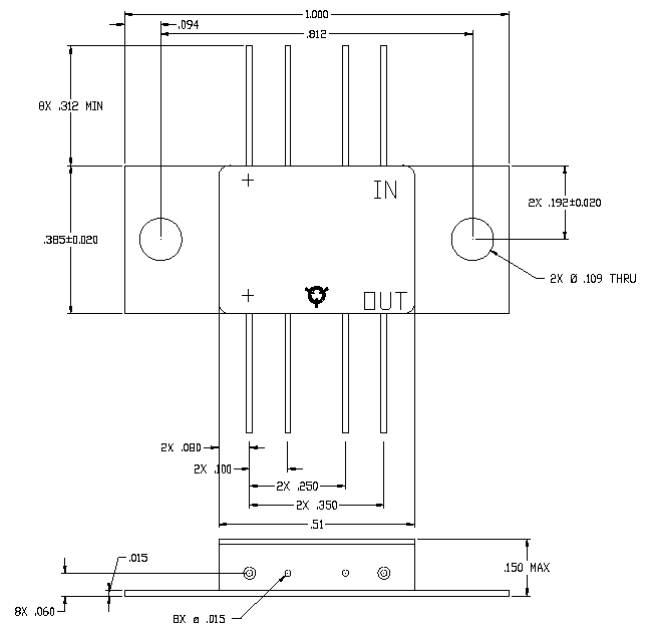

Dimensions are in mm unless otherwise noted.  
 .xxx = ±0.010 (.xx = ±0.85)  
 .xx = ±0.02 (.x = ±0.5)  
 AM-123 Positive voltage only.  
 Weight (approx.) 0.09 ounces, 2.5 grams

## Pin Configuration

Pin #	Function
1	RF OUT
2,3,6,7	GND
4,8	DC IN
5	RF IN

## Ordering Information

Part Number	Package
AM-123 PIN	Flat pack (FP-7)
AMC-123 SMA	Connectorized (C32)

## Electrical Specifications<sup>1,2</sup>: $T_A = -55^\circ\text{C}$ to $+85^\circ\text{C}$ Case Temperature

Parameter	Frequency	Units	Typical	Guaranteed	
			25°C	0° to 50°C	-54° to +85°C*
Small Signal Gain (min.)	5 - 250 MHz 250 - 500 MHz	dB	9.8 9.3	9.5 9.0	9.0 8.5
Gain Flatness (max.)	5 - 500 MHz	dB	±0.3	±0.7	±1.0
Reverse Isolation	5 - 500 MHz	dB	16	—	—
Noise Figure (max.)	5 - 500 MHz	dB	4.0	5.0	5.5
Power Output @ 1 dB comp. (min.)	—	dBm	19.0	18.0	17.5
IP3	5 - 500 MHz	dBm	34	33	—
IP2	5 - 500 MHz	dBm	48	40	—
Second Order Harmonic IP	5 - 500 MHz	dBm	54	—	—
VSWR In/Out	5 - 500 MHz 20 - 400 MHz	Max.	2.1:1 / 2.1:1 1.6:1 / 1.8:1	2.3:1 / 2.2:1 2.0:1 / 2.0:1	2.5:1 / 2.4:1 2.2:1 / 2.2:1
DC Current @ 15 Volts (max.)	—	mA	65	69	72

1. All specifications apply when operated at 15 VDC, with 50 ohms source and load impedance.

2. Heat Sinking: Operation at case temperature above 95°C is not recommended. Heat sinking adequate to dissipate 1 W must be provided in use.

## Absolute Maximum Ratings<sup>3,4</sup>

Parameter	Absolute Maximum
Input Power	23 dBm
$V_{BIAS}$	15.75 V
Operating Temperature	-55°C to +85°C
Storage Temperature	-65°C to +125°C

- Exceeding any one or combination of these limits may cause permanent damage to this device.
- MACOM does not recommend sustained operation near these survivability limits.

## Handling Procedures

Please observe the following precautions to avoid damage:

## Static Sensitivity

These electronic devices are sensitive to electrostatic discharge (ESD) and can be damaged by static electricity. Proper ESD control techniques should be used when handling these devices.

## S-Parameter Data

Frequency (MHz)	S11 MAG/ANG	S21 MAG/ANG	S12 MAG/ANG	S22 MAG/ANG
5	0.21/-69.9	3.15/-158.8	0.11/171.3	0.15/92.8
10	0.11/-81.5	3.17/-172.2	0.11/175.0	0.06/116.1
20	0.08/-88.5	3.18/-178.4	0.12/171.7	0.04/139.8
50	0.06/-108.4	3.17/162.9	0.13/159.9	0.03/174.7
100	0.05/-122.8	3.14/142.8	0.13/141.4	0.04/-163.9
200	0.05/-141.8	3.11/104.8	0.13/102.1	0.04/-119.4
300	0.07/-155.4	3.09/66.9	0.12/64.9	0.14/-114.6
400	0.15/177.2	3.08/26.7	0.11/27.3	0.22/-153.2
500	0.20/151.3	3.05/-21.9	0.09/-20.9	0.25/83.4

## Typical Performance Curves

**Gain**

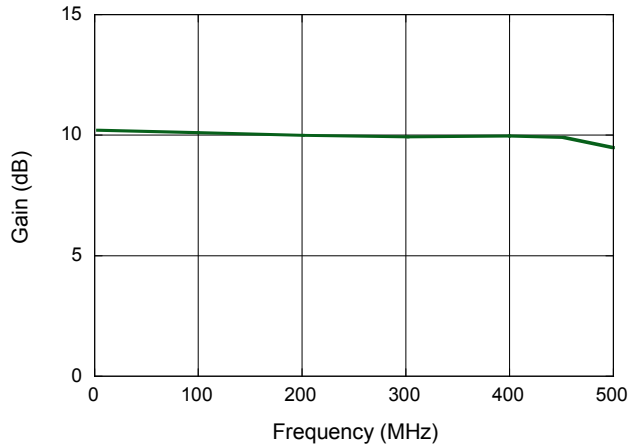

**VSWR**

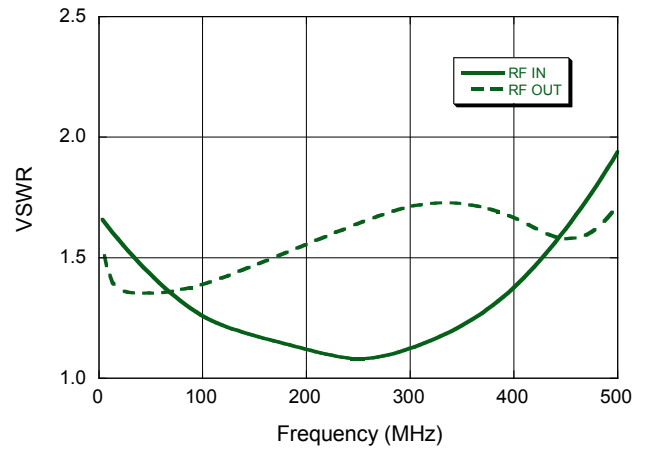

**Noise Figure**

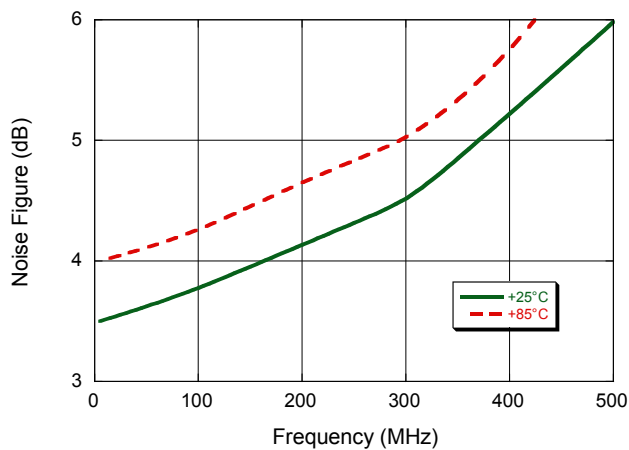

**P1dB**

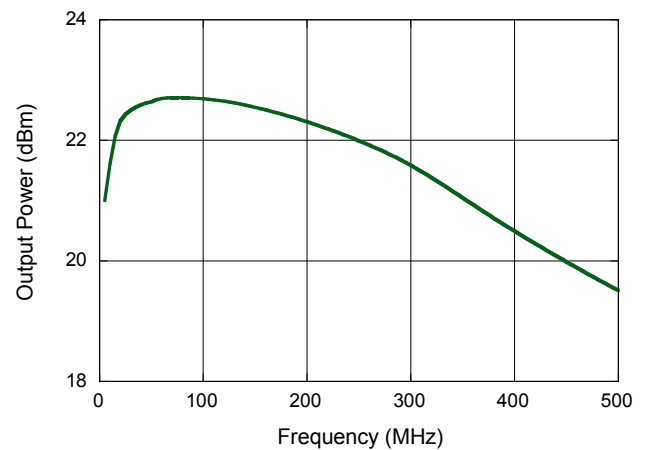

**Intermodulation Intercept, IP2**

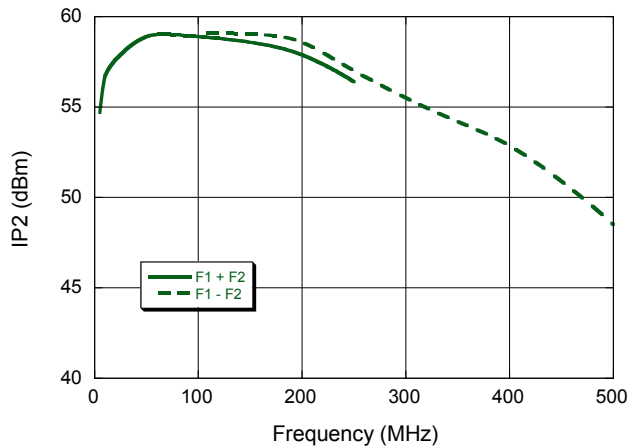

**Intermodulation Intercept, IP3**

