

AM-155 / AMC-155



**High Dynamic Range Amplifier,
12.5 dB Gain, 300 - 1000 MHz**

Rev. V4

Features

- 2.5 dB Typical Midband Noise Figure
- +21 dBm Typical Midband Output Power
- +37 dBm Typical Midband Third Order Intercept

Description

M/A-COM's AM-155 is a coupler feedback amplifier with high intercept and compression points. The use of coupler feedback minimizes noise figure and current in a high intercept amplifier. This amplifier is packaged in a TO-8 package. Due to the internal power dissipation the thermal rise minimized. The ground plane on the PC board should be configured to remove heat from under the package. AM-155 is ideally suited for use where a high intercept, high reliability amplifier is required.

Ordering Information

Part Number	Package
AM-155 PIN ³	TO-8-1
AMC-155 SMA	Connectorized

3. Mounting kit part number AU00071 required for PCB applications.

Absolute Maximum Ratings¹

Parameter	Absolute Maximum
Max. Input Power	+10 dBm
V _{bias}	+15.75 V
Operating Temperature	-55°C to +85°C
Storage Temperature	-65°C to +125°C

1. Operation of this device above any one of these parameters may cause permanent damage.

Outline Drawing: TO-8-1 *

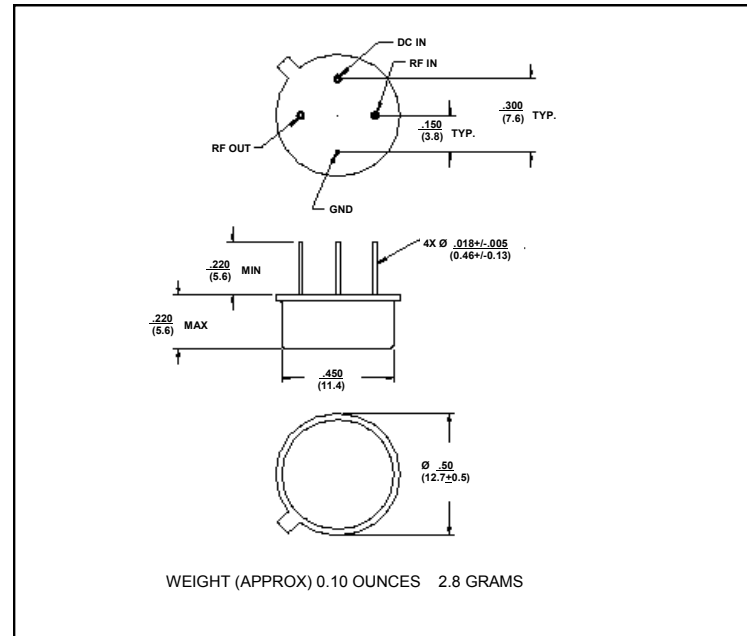

Outline Drawing: SMA Connectorized *

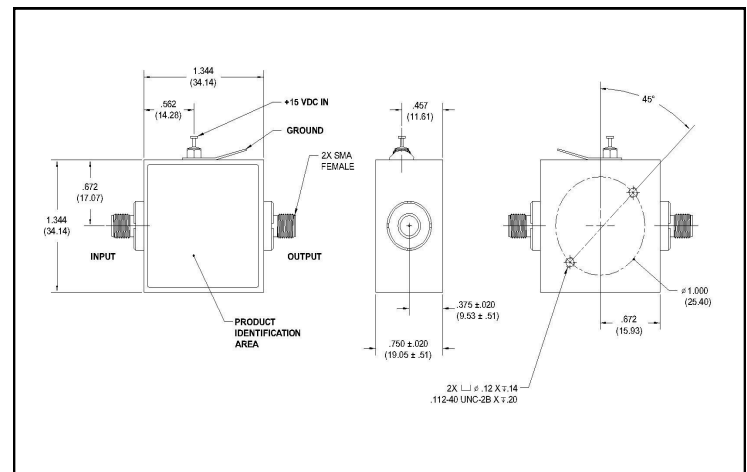

* Dimensions are inches (millimeters) ±0.015 (0.38) unless otherwise specified.

High Dynamic Range Amplifier, 12.5 dB Gain, 300 - 1000 MHz

Rev. V4

Electrical Specifications: ^{2,3} T_A = -55°C to +85°C Case Temperature

Parameter	Test Conditions	Frequency	Units	Min.	Typ.	Max.
Gain	@+25°C	600 MHz	dB	11.25	12.25	13.25
Frequency Response	—	300 - 1000 MHz	dB	—	—	±0.5
Gain Variation with Temperature	—	300 - 1000 MHz	dB	—	—	±0.7
1 dB Compression	Output Power	300 - 1000 MHz	dBm	+18	—	—
Noise Figure	—	300 - 700 MHz 300 - 1000 MHz	dB dB	— —	— —	4.0 5.5
Reverse Transmission	—	300 - 1000 MHz	dB	—	-14	-10
VSWR	Input Output	300 - 1000 MHz	Ratio Ratio	— —	— —	2.0:1 3.0:1
Output IP ₂	Two-Tone inputs up to +5 dBm	300 - 1000 MHz	dBm	+40	—	—
Output IP ₃	Two-Tone inputs up to +5 dBm	300 - 1000 MHz	dBm	+27	—	—
Vbias	—	—	VDC	+14.5	+15.0	+15.5
Ibias	Vbias = +15.0 VDC	—	mA	—	50	60
Power Dissipation	@ +15 V Bias	—	mW	—	750	—

2. All specifications apply when operated at +15 VDC, with 50 ohms source and load impedance.

3. Heat Sinking: Operation at case temperature above 95°C is not recommended. Heat sinking adequate to dissipate 0.8W must be provided in use.

S-Parameter Data

Frequency (MHz)	S11 MAG/ANG	S21 MAG/ANG	S12 MAG/ANG	S22 MAG/ANG
300	0.30/42.3	4.05/166.3	0.18/173.3	0.36/87.8
350	0.26/12.9	4.12/153.2	0.18/161.3	0.33/80.5
400	0.24/-25.7	4.13/142.0	0.19/150.6	0.30/76.2
500	0.20/-88.2	4.03/122.0	0.20/131.8	0.28/73.4
600	0.23/-123.0	3.94/104.9	0.20/115.3	0.27/67.8
700	0.26/-144.7	3.88/89.4	0.21/100.1	0.28/51.3
800	0.29/-163.9	3.88/74.5	0.21/85.2	0.28/21.3
900	0.27/175.6	4.01/59.5	0.22/69.8	0.30/-20.2
1000	0.25/147.1	4.22/41.3	0.23/53.6	0.32/-63.0

2

Typical Performance Curves

Gain vs. Frequency

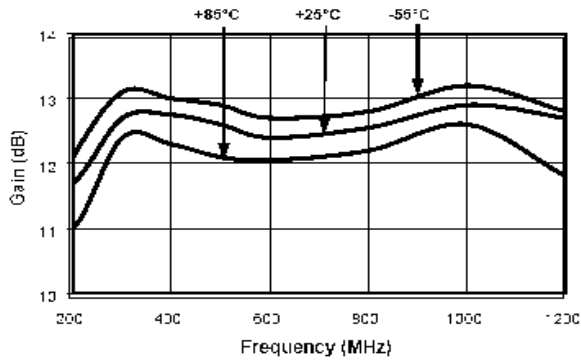

VSWR vs. Frequency

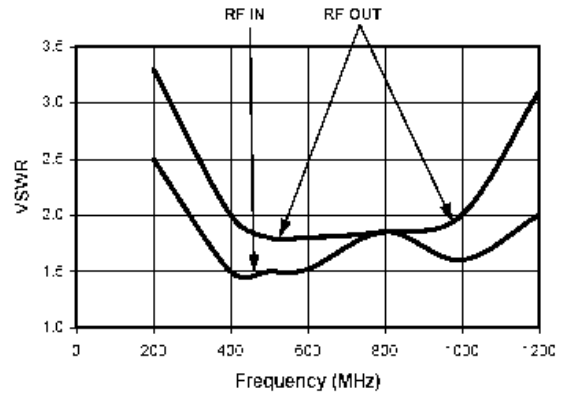

Noise Figure

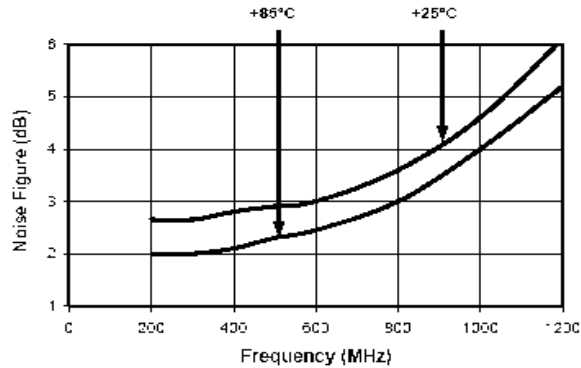

1 dB Compression

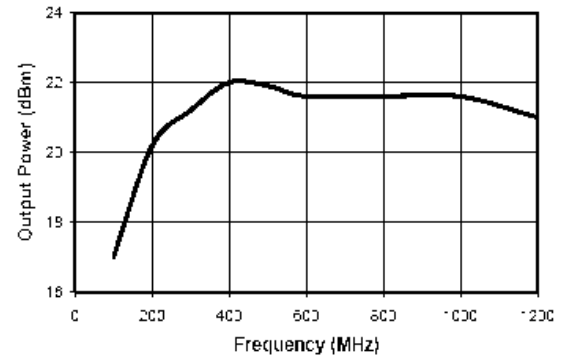

Intermodulation Intercept

