

AMJD31C-HF (NPN)

RoHS Device
Halogen Free

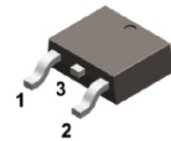

Features

- Lead formed for surface mount application.
- Straight lead.
- AEC-Q101 Qualified.

Mechanical data

- Case: TO-252, molded plastic.
- Terminals: Tin-plated, solderability per MIL-STD-202, method 208.
- Molding compound: UL flammability classification rating 94V-0.
- Mounting position: Any.

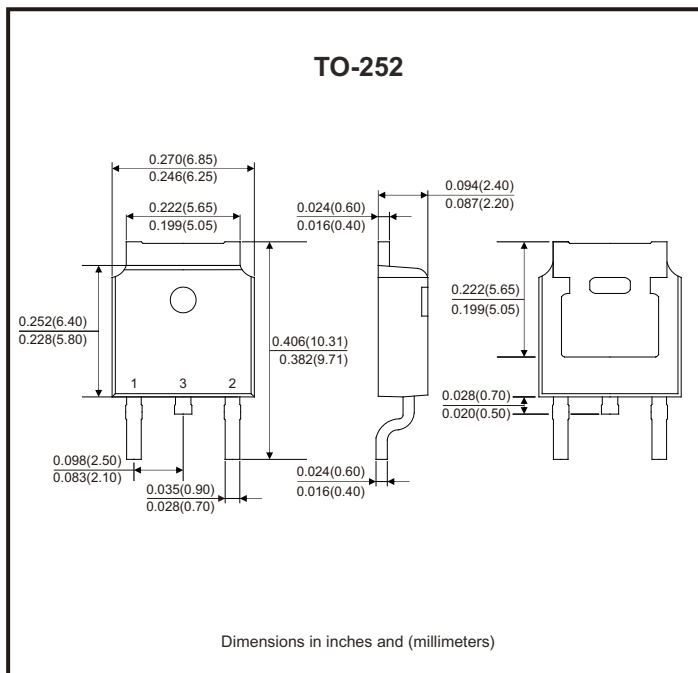

Circuit Diagram

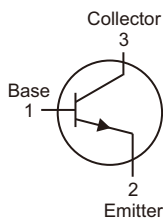

Maximum Ratings (at Ta=25°C unless otherwise specified)

Parameter	Symbol	Value	Units
Collector-base breakdown voltage	V _{CBO}	100	V
Collector-emitter breakdown voltage	V _{CEO}	100	V
Emitter-base breakdown voltage	V _{EBO}	5	V
Collector current (continuous)	I _C	3	A
Collector current (peak)	I _{CM}	5	A
Base current (continuous)	I _B	1	A
Power dissipation	P _D	1.25	W
Junction temperature range	T _J	-65 to +150	°C
Storage temperature range	T _{STG}	-65 to +150	°C

Electrical Characteristics (at Ta=25°C unless otherwise specified)

Parameter	Conditions	Symbol	Min	Typ	Max	Units
Collector-base breakdown voltage	$I_C = 100\mu A, I_E = 0$	$V_{(BR)CBO}$	100			V
Collector-emitter breakdown voltage	$I_C = 30mA, I_B = 0$	$V_{(BR)CEO}$	100			V
Emitter-base breakdown voltage	$I_E = 1mA, I_C = 0$	$V_{(BR)EBO}$	5			V
Collector cut-off current	$V_{CB} = 100V, I_E = 0$	I_{CBO}			50	μA
Collector cut-off current	$V_{CE} = 60V, I_B = 0$	I_{CEO}			50	μA
Collector cut-off current	$V_{CE} = 100V, V_{EB} = 0$	I_{CES}			20	μA
Emitter cut-off current	$V_{EB} = 5V, I_C = 0$	I_{EBO}			1	mA
DC current gain	$V_{CE} = 4V, I_C = 1A$	h_{FE}	25			
	$V_{CE} = 4V, I_C = 3A$	h_{FE}	15		75	
Collector-emitter saturation voltage	$I_C = 3A, I_B = 0.375A$	$V_{CE(sat)}$			1.2	V
Base-emitter on voltage	$V_{CE} = 4V, I_C = 3A$	$V_{BE(on)}$			1.8	V
Transition frequency	$I_C = 0.5A, V_{CE} = 10V$	f_T	3			MHz

Rating and Characteristic Curves (AMJD31C-HF)

Fig.1 - h_{FE} vs. I_c

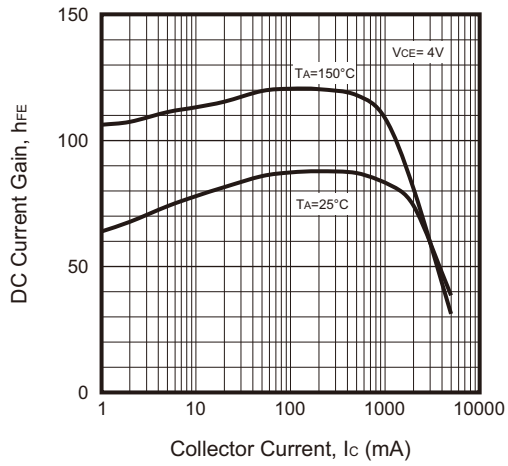

Fig.2 - $V_{CE(sat)}$ vs. I_c

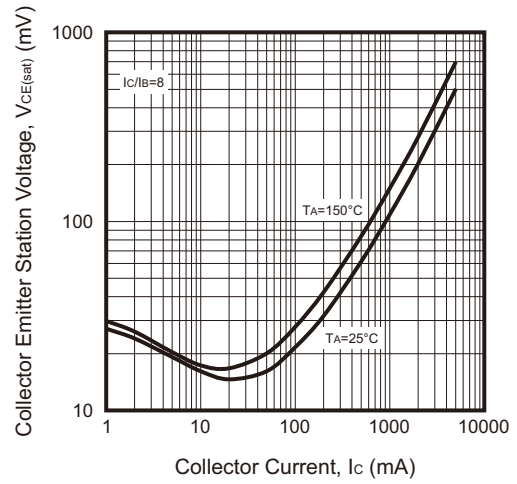

Fig.3 - $V_{BE(sat)}$ vs. I_c

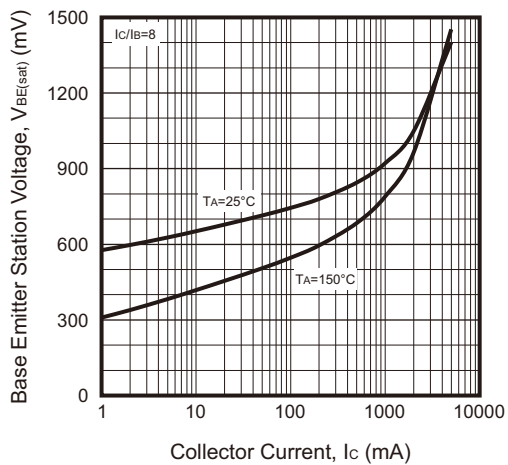
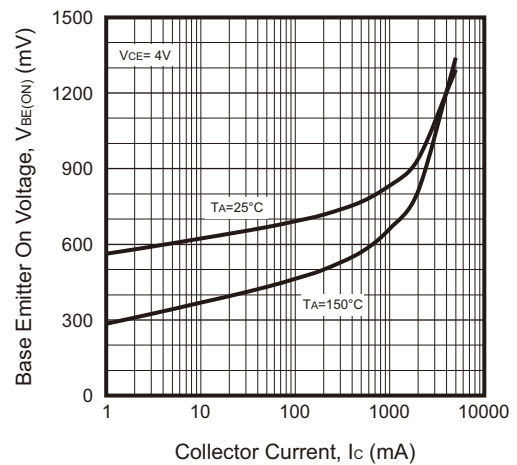
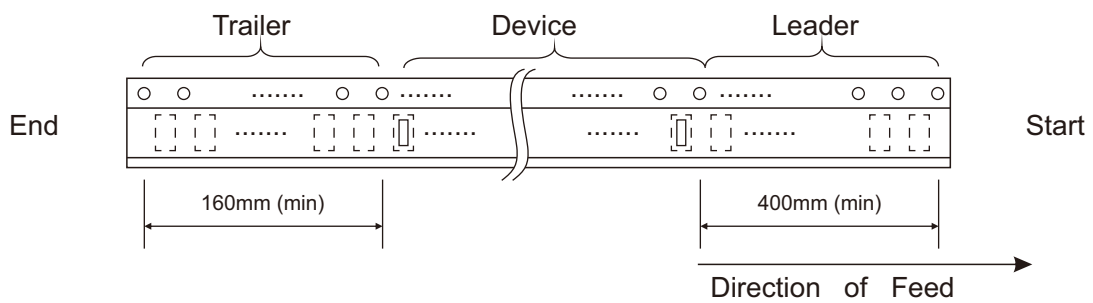
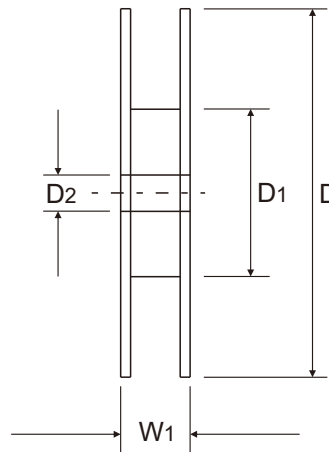
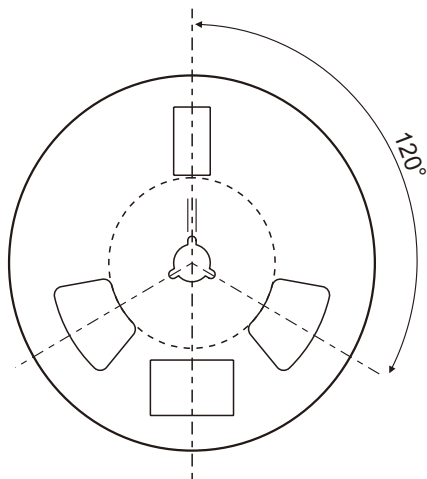
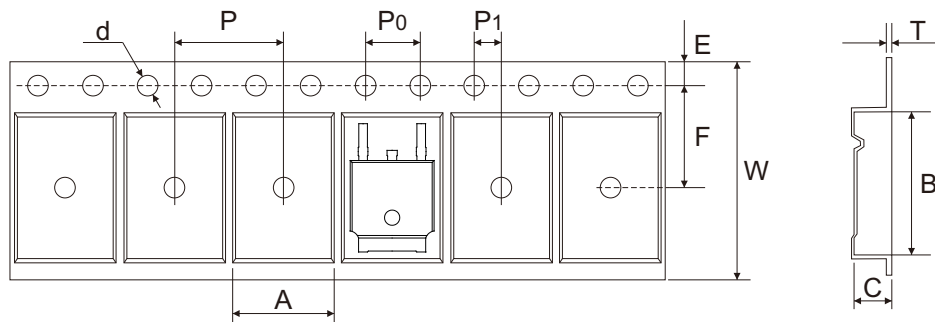

Fig.4 - $V_{BE(ON)}$ vs. I_c



Reel Taping Specification



TO-252	SYMBOL	A	B	C	d	D	D1	D2
	(mm)	6.90 ± 0.10	10.50 ± 0.10	2.70 ± 0.10	1.50 + 0.25	330 ± 1.00	100 ± 1.00	13.00 ± 0.20
	(inch)	0.272 ± 0.004	0.413 ± 0.004	0.106 ± 0.004	0.059 + 0.010	12.992 ± 0.039	3.937 ± 0.039	0.512 ± 0.008

TO-252	SYMBOL	E	F	P	P0	P1	T	W	W1
	(mm)	1.75 ± 0.10	7.50 ± 0.10	8.00 ± 0.10	4.00 ± 0.10	2.00 ± 0.10	0.30 ± 0.10	16.00 + 0.30 - 0.20	21.00 ± 0.30
	(inch)	0.069 ± 0.004	0.295 ± 0.004	0.315 ± 0.004	0.157 ± 0.004	0.079 ± 0.004	0.012 ± 0.004	0.630 + 0.012 - 0.008	0.827 ± 0.012