

## FEATURES

- Low offset voltage: 50  $\mu\text{V}$  maximum**
- Very low offset voltage drift: 0.3  $\mu\text{V}/^\circ\text{C}$  maximum**
- Low noise: 0.12  $\mu\text{V}$  p-p (0.1 Hz to 10 Hz)**
- Excellent output drive:  $\pm 10\text{ V}$  at  $\pm 50\text{ mA}$**
- Capacitive load stability: up to 1  $\mu\text{F}$**
- Gain range: 0.1 to 10,000**
- Excellent linearity: 16-bit at  $G = 1000$**
- High CMR: 125 dB minimum ( $G = 1000$ )**
- Low bias current: 4 nA maximum**
- Can be configured as a precision op amp**
- Output-stage thermal shutdown**
- Available in die form**

## GENERAL DESCRIPTION

The AMP01<sup>1</sup> is a monolithic instrumentation amplifier designed for high-precision data acquisition and instrumentation applications. The design combines the conventional features of an instrumentation amplifier with a high current output stage. The output remains stable with high capacitance loads (1  $\mu\text{F}$ ), a unique ability for an instrumentation amplifier. Consequently, the AMP01 can amplify low level signals for transmission through long cables without requiring an output buffer. The output stage can be configured as a voltage or current generator.

Input offset voltage is very low (20  $\mu\text{V}$ ), which generally eliminates the external null potentiometer. Temperature

changes have minimal effect on offset;  $\text{TCV}_{\text{IOS}}$  is typically 0.15  $\mu\text{V}/^\circ\text{C}$ . Excellent low frequency noise performance is achieved with a minimal compromise on input protection. The bias current is very low, less than 10 nA over the military temperature range. High common-mode rejection of 130 dB, 16-bit linearity at a gain of 1000, and 50 mA peak output current are achievable simultaneously. This combination takes the instrumentation amplifier one step further towards the ideal amplifier.

AC performance complements the superb dc specifications. The AMP01 slews at 4.5 V/ $\mu\text{s}$  into capacitive loads of up to 15 nF, settles in 50  $\mu\text{s}$  to 0.01% at a gain of 1000, and boasts a healthy 26 MHz gain bandwidth product. These features make the AMP01 ideal for high speed data acquisition systems.

The gain is set by the ratio of two external resistors over a range of 0.1 to 10,000. A very low gain temperature coefficient of 10 ppm/ $^\circ\text{C}$  is achievable over the whole gain range. Output voltage swing is guaranteed with three load resistances: 50  $\Omega$ , 500  $\Omega$ , and 2 k $\Omega$ . Loaded with 500  $\Omega$ , the output delivers  $\pm 13.0\text{ V}$  minimum. A thermal shutdown circuit prevents destruction of the output transistors during overload conditions.

The AMP01 can also be configured as a high performance operational amplifier. In many applications, the AMP01 can be used in place of op amp/power buffer combinations.

## FUNCTIONAL BLOCK DIAGRAM



Figure 1.

<sup>1</sup> Protected under U.S. Patents 4,471,321 and 4,503,381.

## TABLE OF CONTENTS

Features .....	1	Input Bias and Offset Currents.....	18
General Description .....	1	Gain.....	18
Functional Block Diagram .....	1	Common-Mode Rejection .....	19
Revision History .....	2	Active Guard Drive .....	19
Specifications.....	3	Grounding.....	19
Electrical Characteristics .....	3	Sense and Reference Terminals .....	20
Dice Characteristics .....	8	Driving 50 $\Omega$ Loads.....	21
Wafer Test Limits (AMP01NBC) .....	9	Heatsinking .....	22
Absolute Maximum Ratings.....	10	Overvoltage Protection.....	22
Thermal Resistance .....	10	Power Supply Considerations.....	22
ESD Caution.....	10	Applications Circuits.....	23
Pin Configurations and Function Descriptions .....	11	Outline Dimensions .....	29
Typical Performance Characteristics .....	13	Ordering Guide .....	29
Theory of Operation .....	18		
Input and Output Offset Voltages .....	18		

## REVISION HISTORY

### 12/2019—Rev. E to Rev. F

Changes to Table 7.....	10
Changes to Ordering Guide .....	29

### 1/2017—Rev. D to Rev. E

Updated Format.....	Universal
Deleted E-28A Package.....	Universal
Changed R-20 Package to RW-20 Package.....	Universal
Deleted Pin Connections Section and Figure 1 to Figure 3; Renumbered Sequentially.....	1
Added Functional Block Diagram Section and Figure 1; Renumbered Sequentially.....	1
Changes to Figure 2.....	8
Changes to Table 5.....	9

Deleted Figure 5.....	9
Deleted Table 6; Renumbered Sequentially .....	10
Added Table 6 and Table 7; Renumbered Sequentially .....	10
Added Pin Configurations and Function Descriptions Section, Figure 3, and Table 8 .....	11
Added Figure 4 and Table 9 .....	12
Changes to Input and Output Offset Voltages Section and Gain Section .....	18
Changes to Power Supply Considerations Section .....	22
Added Applications Circuits Section.....	29
Updated Package Drawings .....	29
Changes to Ordering Guide .....	29

## SPECIFICATIONS

## ELECTRICAL CHARACTERISTICS

$V_S = \pm 15\text{ V}$ ,  $R_S = 10\text{ k}\Omega$ ,  $R_L = 2\text{ k}\Omega$ ,  $T_A = 25^\circ\text{C}$ , unless otherwise noted.

Table 1.

Parameter	Symbol	Test Conditions/Comments	AMP01A			AMP01B			Unit
			Min	Typ	Max	Min	Typ	Max	
OFFSET VOLTAGE									
Input Offset Voltage	$V_{IOS}$	$T_A = 25^\circ\text{C}$		20	50		40	100	$\mu\text{V}$
		$-55^\circ\text{C} \leq T_A \leq +125^\circ\text{C}$		40	80		60	150	$\mu\text{V}$
Input Offset Voltage Drift	$TCV_{IOS}$	$-55^\circ\text{C} \leq T_A \leq +125^\circ\text{C}$		0.15	0.3		0.3	1.0	$\mu\text{V}/^\circ\text{C}$
Output Offset Voltage	$V_{OOS}$	$T_A = 25^\circ\text{C}$		1	3		2	6	mV
		$-55^\circ\text{C} \leq T_A \leq +125^\circ\text{C}$		3	6		6	10	mV
Output Offset Voltage Drift	$TCV_{OOS}$	$R_G = \infty$							
		$-55^\circ\text{C} \leq T_A \leq +125^\circ\text{C}$		20	50		50	120	$\mu\text{V}/^\circ\text{C}$
Offset Referred to Input vs. Positive Supply	PSR	$V_+ = +5\text{ V to } +15\text{ V}$							
		$G = 1000$	120	130		110	120		dB
		$G = 100$	110	130		100	120		dB
		$G = 10$	95	110		90	100		dB
		$G = 1$	75	90		70	80		dB
		$-55^\circ\text{C} \leq T_A \leq +125^\circ\text{C}$							
		$G = 1000$	120	130		110	120		dB
		$G = 100$	110	130		100	120		dB
		$G = 10$	95	110		90	100		dB
		$G = 1$	75	90		70	80		dB
Offset Referred to Input vs. Negative Supply	PSR	$V_- = -5\text{ V to } -15\text{ V}$							
		$G = 1000$	105	125		105	115		dB
		$G = 100$	90	105		90	95		dB
		$G = 10$	70	85		70	75		dB
		$G = 1$	50	65		50	60		dB
		$-55^\circ\text{C} \leq T_A \leq +125^\circ\text{C}$							
		$G = 1000$	105	125		105	115		dB
		$G = 100$	90	105		90	95		dB
		$G = 10$	70	85		70	75		dB
		$G = 1$	50	85		50	60		dB
Input Offset Voltage Trim Range		$V_S = \pm 4.5\text{ V to } \pm 18\text{ V}^1$		$\pm 6$			$\pm 6$		mV
Output Offset Voltage Trim Range		$V_S = \pm 4.5\text{ V to } \pm 18\text{ V}^1$		$\pm 100$			$\pm 100$		mV
INPUT CURRENT									
Input Bias Current	$I_B$	$T_A = 25^\circ\text{C}$		1	4		2	6	nA
		$-55^\circ\text{C} \leq T_A \leq +125^\circ\text{C}$		4	10		6	15	nA
Input Bias Current Drift	$TCI_B$	$-55^\circ\text{C} \leq T_A \leq +125^\circ\text{C}$		40			50		$\text{pA}/^\circ\text{C}$
Input Offset Current	$I_{OS}$	$T_A = 25^\circ\text{C}$		0.2	1.0		0.5	2.0	nA
		$-55^\circ\text{C} \leq T_A \leq +125^\circ\text{C}$		0.5	3.0		1.0	6.0	nA
Input Offset Current Drift	$TCI_{OS}$	$-55^\circ\text{C} \leq T_A \leq +125^\circ\text{C}$		3			5		$\text{pA}/^\circ\text{C}$

Parameter	Symbol	Test Conditions/Comments	AMP01A			AMP01B			Unit	
			Min	Typ	Max	Min	Typ	Max		
INPUT										
Input Resistance	R <sub>IN</sub>	Differential, G = 1000		1			1		GΩ	
		Differential, G ≤ 100		10			10		GΩ	
		Common mode, G = 1000		20			20		GΩ	
Input Voltage Range	IVR	T <sub>A</sub> = 25°C <sup>2</sup>	±10.5			±10.5			V	
		-55°C ≤ T <sub>A</sub> ≤ +125°C	±10.0			±10.0			V	
Common-Mode Rejection	CMR	V <sub>CM</sub> = ±10 V, 1 kΩ source imbalance								
		G = 1000	125	130		115	125		dB	
		G = 100	120	130		110	125		dB	
		G = 10	100	120		95	110		dB	
		G = 1	85	100		75	90		dB	
		-55°C ≤ T <sub>A</sub> ≤ +125°C								
		G = 1000	120	125		110	120		dB	
		G = 100	115	125		105	120		dB	
		G = 10	95	115		90	105		dB	
G = 1	80	95		75	90		dB			

<sup>1</sup> V<sub>IOS</sub> and V<sub>OOS</sub> nulling have minimal effect on TCV<sub>IOS</sub> and TCV<sub>OOS</sub>, respectively.

<sup>2</sup> Refer to the Common-Mode Rejection section.

$V_S = \pm 15\text{ V}$ ,  $R_S = 10\text{ k}\Omega$ ,  $R_L = 2\text{ k}\Omega$ ,  $T_A = 25^\circ\text{C}$ ,  $-25^\circ\text{C} \leq T_A \leq +85^\circ\text{C}$  for E and F grades,  $0^\circ\text{C} \leq T_A \leq 70^\circ\text{C}$  for G grade, unless otherwise noted.

Table 2.

Parameter	Symbol	Test Conditions/Comments	AMP01E			AMP01F/AMP01G			Unit
			Min	Typ	Max	Min	Typ	Max	
OFFSET VOLTAGE									
Input Offset Voltage	$V_{IOS}$	$T_A = 25^\circ\text{C}$		20	50		40	100	$\mu\text{V}$
		$T_{MIN} \leq T_A \leq T_{MAX}$		40	80		60	150	$\mu\text{V}$
Input Offset Voltage Drift	$TCV_{IOS}$	$T_{MIN} \leq T_A \leq T_{MAX}^1$		0.15	0.3		0.3	1.0	$\mu\text{V}/^\circ\text{C}$
Output Offset Voltage	$V_{OOS}$	$T_A = 25^\circ\text{C}$		1	3		2	6	mV
		$T_{MIN} \leq T_A \leq T_{MAX}$		3	6		6	10	mV
Output Offset Voltage Drift	$TCV_{OOS}$	$R_G = \infty^1$							
		$-55^\circ\text{C} \leq T_A \leq +125^\circ\text{C}$		20	100		50	120	$\mu\text{V}/^\circ\text{C}$
Offset Referred to Input vs. Positive Supply	PSR	$V_+ = +5\text{ V to } +15\text{ V}$							
		$G = 1000$	120	130		110	120		dB
		$G = 100$	110	130		100	120		dB
		$G = 10$	95	110		90	100		dB
		$G = 1$	75	90		70	80		dB
		$T_{MIN} \leq T_A \leq T_{MAX}$							
		$G = 1000$	120	130		110	120		dB
		$G = 100$	110	130		100	120		dB
		$G = 10$	95	110		90	100		dB
		$G = 1$	75	90		70	80		dB
Offset Referred to Input vs. Negative Supply	PSR	$V_- = -5\text{ V to } -15\text{ V}$							
		$G = 1000$	110	125		105	115		dB
		$G = 100$	95	105		90	95		dB
		$G = 10$	75	85		70	75		dB
		$G = 1$	55	65		50	60		dB
		$T_{MIN} \leq T_A \leq T_{MAX}$							
		$G = 1000$	110	125		105	115		dB
		$G = 100$	95	105		90	95		dB
		$G = 10$	75	85		70	75		dB
		$G = 1$	55	65		50	60		dB
Input Offset Voltage Trim Range		$V_S = \pm 4.5\text{ V to } \pm 18\text{ V}^2$		$\pm 6$			$\pm 6$		mV
Output Offset Voltage Trim Range		$V_S = \pm 4.5\text{ V to } \pm 18\text{ V}^2$		$\pm 100$			$\pm 100$		mV
INPUT CURRENT									
Input Bias Current	$I_B$	$T_A = 25^\circ\text{C}$		1	4		2	6	nA
		$T_{MIN} \leq T_A \leq T_{MAX}$		4	10		6	15	nA
Input Bias Current Drift	$TCI_B$	$T_{MIN} \leq T_A \leq T_{MAX}$		40			50		$\text{pA}/^\circ\text{C}$
Input Offset Current	$I_{OS}$	$T_A = 25^\circ\text{C}$		0.2	1.0		0.5	2.0	nA
		$T_{MIN} \leq T_A \leq T_{MAX}$		0.5	3.0		1.0	6.0	nA
Input Offset Current Drift	$TCI_{OS}$	$T_{MIN} \leq T_A \leq T_{MAX}$		3			5		$\text{pA}/^\circ\text{C}$

Parameter	Symbol	Test Conditions/Comments	AMP01E			AMP01F/AMP01G			Unit	
			Min	Typ	Max	Min	Typ	Max		
INPUT										
Input Resistance	R <sub>IN</sub>	Differential, G = 1000		1			1		GΩ	
		Differential, G ≤ 100		10			10		GΩ	
		Common mode, G = 1000		20			20		GΩ	
Input Voltage Range	IVR	T <sub>A</sub> = 25°C <sup>3</sup>	±10.5			±10.5			V	
		T <sub>MIN</sub> ≤ T <sub>A</sub> ≤ T <sub>MAX</sub>	±10.0			±10.0			V	
Common-Mode Rejection	CMR	V <sub>CM</sub> = ±10 V, 1 kΩ source imbalance								
		G = 1000	125	130		115	125		dB	
		G = 100	120	130		110	125		dB	
		G = 10	100	120		95	110		dB	
		G = 1	85	100		75	90		dB	
		T <sub>MIN</sub> ≤ T <sub>A</sub> ≤ T <sub>MAX</sub>								
		G = 1000	120	125		110	120		dB	
		G = 100	115	125		105	120		dB	
		G = 10	95	115		90	105		dB	
G = 1	80	95		75	90		dB			

<sup>1</sup> Sample tested.

<sup>2</sup> V<sub>IOS</sub> and V<sub>OOS</sub> nulling has minimal effect on TCV<sub>IOS</sub> and TCV<sub>OOS</sub>, respectively.

<sup>3</sup> Refer to the Common-Mode Rejection section.

$V_S = \pm 15\text{ V}$ ,  $R_S = 10\text{ k}\Omega$ ,  $R_L = 2\text{ k}\Omega$ ,  $T_A = 25^\circ\text{C}$ , unless otherwise noted.

Table 3.

Parameter	Symbol	Test Conditions/Comments	AMP01A/AMP01E			AMP01B/AMP01F/AMP01G			Unit	
			Min	Typ	Max	Min	Typ	Max		
GAIN										
Gain Equation Accuracy		$G = (20 \times R_S)/R_G$ , accuracy measured from $G = 1$ to 100		0.3	0.6		0.5	0.8	%	
Gain Range	G	$G = 1000^1$	0.1		10,000	0.1		10,000	V/V	
Nonlinearity		$G = 100^1$		0.0007	0.005		0.0007	0.005	%	
		$G = 10^1$			0.005			0.005	%	
		$G = 1^1$			0.010			0.015	%	
Temperature Coefficient	$G_{TC}$	$1 \leq G \leq 1000^{1,2}$		5	10		5	15	ppm/°C	
OUTPUT RATING										
Output Voltage Swing	$V_{OUT}$	$R_L = 2\text{ k}\Omega$	$\pm 13.0$	$\pm 13.8$		$\pm 13.0$	$\pm 13.8$		V	
		$R_L = 500\text{ k}\Omega$	$\pm 13.0$	$\pm 13.5$		$\pm 13.0$	$\pm 13.5$		V	
		$R_L = 50\text{ k}\Omega$	$\pm 2.5$	$\pm 4.0$		$\pm 2.5$	$\pm 4.0$		V	
		$R_L = 2\text{ k}\Omega$ over temperature	$\pm 12.0$	$\pm 13.8$		$\pm 12.0$	$\pm 13.8$		V	
		$R_L = 500\text{ k}\Omega^3$	$\pm 12.0$	$\pm 13.5$		$\pm 12.0$	$\pm 13.5$		V	
Positive Current Limit		Output to ground short	60	100	120	60	100	120	mA	
Negative Current Limit		Output to ground short	60	90	120	60	90	120	mA	
Capacitive Load Stability		$1 \leq G \leq 1000$ , no oscillations <sup>1</sup>	0.1	1		0.1	1		$\mu\text{F}$	
Thermal Shutdown Temperature		Junction temperature		165			165		°C	
NOISE										
Voltage Density, RTI	$e_n$	$f_0 = 1\text{ kHz}$								
		$G = 1000$		5		5			nV/ $\sqrt{\text{Hz}}$	
		$G = 100$		10		10			nV/ $\sqrt{\text{Hz}}$	
		$G = 10$		59		59			nV/ $\sqrt{\text{Hz}}$	
Noise Current Density, RTI	$i_n$	$f_0 = 1\text{ kHz}, G = 1000$		540		540			nV/ $\sqrt{\text{Hz}}$	
		Input Noise Voltage	$e_n$ p-p	$0.1\text{ Hz to }10\text{ Hz}$		0.15		0.15		pV/ $\sqrt{\text{Hz}}$
				$G = 1000$		0.12		0.12		$\mu\text{V p-p}$
				$G = 100$		0.16		0.16		$\mu\text{V p-p}$
	$G = 10$		1.4		1.4		$\mu\text{V p-p}$			
	$G = 1$		13		13		$\mu\text{V p-p}$			
Input Noise Current	$i_n$ p-p	$0.1\text{ Hz to }10\text{ Hz}, G = 1000$		2		2		pV p-p		
DYNAMIC RESPONSE										
Small-Signal Bandwidth (-3 dB)	BW	$G = 1$		570		570			kHz	
		$G = 10$		100		100			kHz	
		$G = 100$		82		82			kHz	
		$G = 1000$		26		26			kHz	
Slew Rate Settling Time		$G = 10$	3.5	4.5		3.0	4.5		V/ $\mu\text{s}$	
		To 0.01%, 20 V step								
		$G = 1$		12		12			$\mu\text{s}$	
		$G = 10$		13		13			$\mu\text{s}$	
		$G = 100$		15		15			$\mu\text{s}$	
	$G = 1000$		50		50			$\mu\text{s}$		

<sup>1</sup> Guaranteed by design.

<sup>2</sup> Gain temperature coefficient does not include the effects of gain and scale resistor temperature coefficient match.

<sup>3</sup>  $-55^\circ\text{C} \leq T_A \leq +125^\circ\text{C}$  for A and B grades,  $-25^\circ\text{C} \leq T_A \leq +85^\circ\text{C}$  for E and F grades,  $0^\circ\text{C} \leq T_A \leq 70^\circ\text{C}$  for G grade.

$V_S = \pm 15\text{ V}$ ,  $R_S = 10\text{ k}\Omega$ ,  $R_L = 2\text{ k}\Omega$ ,  $T_A = 25^\circ\text{C}$ , unless otherwise noted.

**Table 4.**

Parameter	Symbol	Test Conditions/Comments	AMP01A/AMP01E			AMP01B/AMP01F/AMP01G			Unit
			Min	Typ	Max	Min	Typ	Max	
SENSE INPUT									
Input Resistance	$R_{IN}$		35	50	65	35	50	65	k $\Omega$
Input Current	$I_{IN}$	Referenced to $V_-$		280			280		$\mu\text{A}$
Voltage Range <sup>1</sup>			-10.5		+15	-10.5		+15	V
REFERENCE INPUT									
Input Resistance	$R_{IN}$		35	50	65	35	50	65	k $\Omega$
Input Current	$I_{IN}$	Referenced to $V_-$		280			280		$\mu\text{A}$
Voltage Range <sup>1</sup>			-10.5		+15	-10.5		+15	V
Gain to Output				1			1		V/V
POWER SUPPLY									
Supply Voltage Range	$V_S$	-25°C ≤ $T_A$ ≤ +85°C for E and F grades, -55 C ≤ $T_A$ ≤ +125°C for A and B grades +V linked to + $V_{OP}$ -V linked to - $V_{OP}$	±4.5		±18	±4.5		±18	V
Quiescent Current	$I_Q$	+V linked to + $V_{OP}$ -V linked to - $V_{OP}$	±4.5	3.0	4.8	±4.5	3.0	4.8	mA
				3.4	4.8		3.4	4.8	mA

<sup>1</sup> Guaranteed by design.

## DICE CHARACTERISTICS

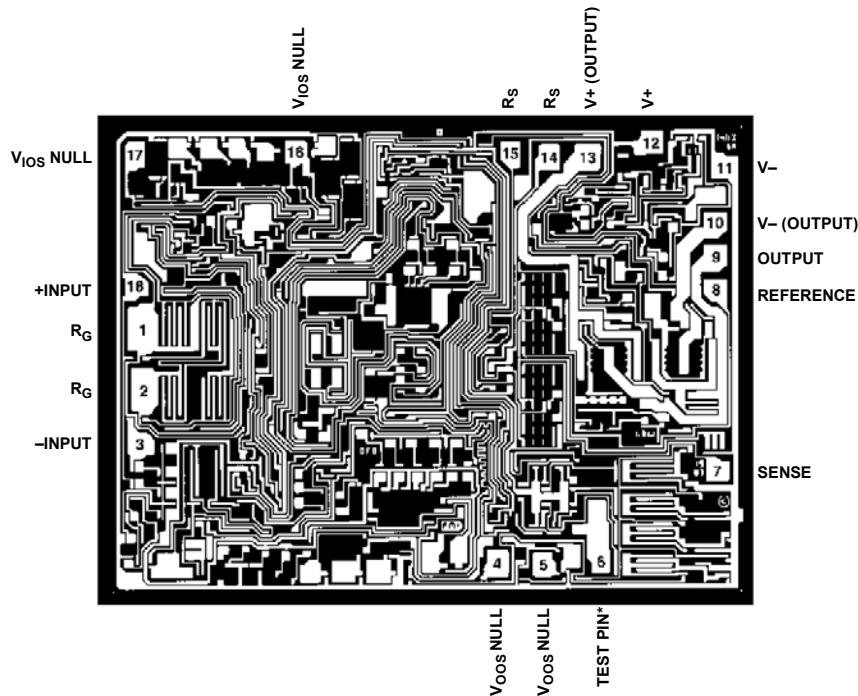

\* MAKE NO ELECTRICAL CONNECTION.

Figure 2. Die Size 0.111 in × 0.149 in, 16,539 sq. mils (2.82 mm × 3.78 mm, 10.67 sq. mm)

14335-102



**WAFER TEST LIMITS (AMP01NBC)**

$V_S = \pm 15\text{ V}$ ,  $R_S = 10\text{ k}\Omega$ ,  $R_L = 2\text{ k}\Omega$ ,  $T_A = 25^\circ\text{C}$ , unless otherwise noted. Electrical tests are performed at wafer probe to the limits shown. Due to variations in assembly methods and normal yield loss, yield after packaging is not guaranteed for standard product dice. Consult the factory to negotiate specifications based on dice lot qualification through sample lot assembly and testing.

**Table 5.**

Parameter	Symbol	Test Conditions/Comments	Min	Typ	Max	Unit
<b>OFFSET VOLTAGE</b>						
Input Offset Voltage	$V_{Ios}$				60	$\mu\text{V}$
Input Offset Voltage Drift	$TCV_{Ios}$			0.15		$\mu\text{V}/^\circ\text{C}$
Output Offset Voltage	$V_{Oos}$				4	mV
Output Offset Voltage Drift	$TCV_{Oos}$	$R_G = \infty$		20		$\mu\text{V}/^\circ\text{C}$
Offset Referred to Input vs. Positive Supply	PSR	$V_+ = 5\text{ V to } 15\text{ V}$				
		$G = 1000$	120			dB
		$G = 100$	110			dB
		$G = 10$	95			dB
		$G = 1$	75			dB
Offset Referred to Input vs. Negative Supply	PSR	$V_- = -5\text{ V to } -15\text{ V}$				
		$G = 1000$	105			dB
		$G = 100$	90			dB
		$G = 10$	70			dB
		$G = 1$	50			dB
<b>INPUT CURRENT</b>						
Input Bias Current	$I_B$				4	nA
Input Bias Current Drift	$TCI_B$			40		$\text{pA}/^\circ\text{C}$
Input Offset Current	$I_{os}$				1	nA
Input Offset Current Drift	$TCI_{os}$			3		$\text{pA}/^\circ\text{C}$
<b>INPUT</b>						
Input Voltage Range	IVR	Guaranteed by CMR tests			$\pm 10$	V min
Common-Mode Rejection	CMR	$V_{CM} = \pm 10\text{ V}$				
		$G = 1000$	125			dB
		$G = 100$	120			dB
		$G = 10$	100			dB
		$G = 1$	85			dB
<b>GAIN</b>						
Gain Equation Accuracy		$G = (20 \times R_S)/R_G$			0.6	%
<b>OUTPUT RATING</b>						
Output Voltage Swing	$V_{OUT}$	$R_L = 2\text{ k}\Omega$	-13		+13	V
		$R_L = 500\text{ k}\Omega$	-13		+13	V
		$R_L = 50\text{ k}\Omega$	-2.5		+2.5	V
Output Current Limit		Output to ground short	-60		+60	mA
		Output to ground short	-120		+120	mA
Quiescent Current	$I_Q$	+V linked to $+V_{OP}$			4.8	mA
		-V linked to $-V_{OP}$			4.8	mA
<b>NOISE</b>						
Nonlinearity	$e_n$	$G = 1000$		0.0007		%
Voltage Noise Density	$i_n$	$G = 1000, f_o = 1\text{ kHz}$		5		$\text{nV}/\sqrt{\text{Hz}}$
Current Noise Density	$e_n\text{ p-p}$	$G = 1000, f_o = 1\text{ kHz}$		0.15		$\text{pA}/\sqrt{\text{Hz}}$
Voltage Noise	$i_n\text{ p-p}$	$G = 1000, 0.1\text{ Hz to } 10\text{ Hz}$		0.12		$\mu\text{V p-p}$
Current Noise	BW	$G = 1000, 0.1\text{ Hz to } 10\text{ Hz}$		2		$\text{pA p-p}$
<b>DYNAMIC RESPONSE</b>						
Small-Signal Bandwidth (-3 dB)	SR	$G = 1000$		26		kHz
Slew Rate	$t_s$	$G = 10$		4.5		$\text{V}/\mu\text{s}$
Settling Time		To 0.01%, 20 V step, $G = 1000$		50		$\mu\text{s}$

## ABSOLUTE MAXIMUM RATINGS

Table 6.

Parameter	Rating
Supply Voltage	±18 V
Internal Power Dissipation <sup>1</sup>	500 mW
Common-Mode Input Voltage	Supply voltage
Differential Input Voltage	
$R_G \geq 2 \text{ k}\Omega$	±20 V
$R_G \leq 2 \text{ k}\Omega$	±10 V
Output Short-Circuit Duration	Indefinite
Storage Temperature Range	−65°C to +150°C
Operating Temperature Range	
AMP01A, AMP01B	−55°C to +125°C
AMP01E, AMP01F	−25°C to +85°C
Lead Temperature (Soldering, 60 sec)	300°C
Dice Junction Temperature (T <sub>J</sub> )	−65°C to +150°C

<sup>1</sup> See Table 7 for maximum ambient temperature rating and derating factor

Stresses at or above those listed under Absolute Maximum Ratings may cause permanent damage to the product. This is a stress rating only; functional operation of the product at these or any other conditions above those indicated in the operational section of this specification is not implied. Operation beyond the maximum operating conditions for extended periods may affect product reliability.

## THERMAL RESISTANCE

$\theta_{JA}$  is specified for the worst-case conditions, that is, a device soldered in a circuit board for surface-mount packages.

Table 7. Thermal Resistance

Package Type	$\theta_{JA}$	$\theta_{JC}$	Unit
Q-18 (100°C Maximum Ambient)	70.4	10.2	°C/W
RW-20	73.7	23.9	°C/W

## ESD CAUTION



**ESD (electrostatic discharge) sensitive device.** Charged devices and circuit boards can discharge without detection. Although this product features patented or proprietary protection circuitry, damage may occur on devices subjected to high energy ESD. Therefore, proper ESD precautions should be taken to avoid performance degradation or loss of functionality.

## PIN CONFIGURATIONS AND FUNCTION DESCRIPTIONS



Figure 3. 18-Lead CERDIP

Table 8. 18-Lead CERDIP Pin Function Descriptions

Pin No.	Mnemonic	Description
1	R <sub>G</sub>	Gain Resistor Pin. Install a resistor between 200 kΩ and 100 Ω to Pin 2.
2	R <sub>G</sub>	Gain Resistor Pin. Install a resistor between 200 kΩ and 100 Ω to Pin 1.
3	-IN	Inverting Signal Input.
4	V <sub>OOS</sub> NULL	Output Offset Voltage Null. Connect a 100 kΩ trimmer across Pin 4 and Pin 5 with wiper to negative supply voltage.
5	V <sub>OOS</sub> NULL	Output Offset Voltage Null. Connect a 100 kΩ trimmer across Pin 4 and Pin 5 with wiper to negative supply voltage.
6	TEST PIN	Test Pin. Pin 6 is reserved for factory test. Do not connect.
7	SENSE	This pin completes the feedback loop for the inverting input amplifier. Normally connected to the output.
8	REFERENCE	This pin shifts the output CMV. Normally connected to ground.
9	OUTPUT	Output of the In-Amp.
10	-V <sub>OP</sub>	Negative Supply Voltage for Output Amplifier.
11	V-	Negative Supply Voltage for Input Amplifiers.
12	V+	Positive Supply Voltage for Input Amplifiers.
13	+V <sub>OP</sub>	Positive Supply Voltage for Output Amplifier.
14	R <sub>S</sub>	Scale Resistor. See the Gain section and Figure 32 for value.
15	R <sub>S</sub>	Scale Resistor. See the Gain section and Figure 32 for value.
16	V <sub>IOS</sub> NULL	Input Offset Voltage Null. Connect a 100 kΩ trimmer across Pin 16 and Pin 17 with wiper to negative supply voltage.
17	V <sub>IOS</sub> NULL	Input Offset Voltage Null. Connect a 100 kΩ trimmer across Pin 16 and Pin 17 with wiper to negative supply voltage.
18	+IN	Noninverting Signal Input.

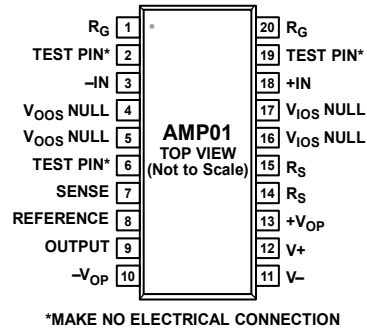

Figure 4. 20-Lead SOIC

Table 9. 20-Lead SOIC Pin Function Descriptions

Pin No.	Mnemonic	Description
1	R <sub>G</sub>	Gain Resistor Pin. Install a resistor between 200 k $\Omega$ and 100 $\Omega$ to Pin 20.
2	TEST PIN	Test Pin. Pin 2 is reserved for factory test. Do not connect.
3	-IN	Inverting Signal Input
4	V <sub>OOS</sub> NULL	Output Offset Voltage Null. Connect a 100 k $\Omega$ trimmer across Pin 4 and Pin 5 with wiper to negative supply voltage.
5	V <sub>OOS</sub> NULL	Output Offset Voltage Null. Connect a 100 k $\Omega$ trimmer across Pin 4 and Pin 5 with wiper to negative supply voltage.
6	TEST PIN	Test Pin. Pin 6 is reserved for factory test. Do not connect.
7	SENSE	This pin completes the feedback loop for the inverting input amplifier. Normally connected to the output.
8	REFERENCE	This pin shifts the output CMV. Normally connected to ground.
9	OUTPUT	Output of the In-Amp.
10	-V <sub>OP</sub>	Negative Supply Voltage for Output Amplifier.
11	V-	Negative Supply Voltage for Input Amplifiers.
12	V+	Positive Supply Voltage for Input Amplifiers.
13	+V <sub>OP</sub>	Positive Supply Voltage for Output Amplifier.
14	R <sub>S</sub>	Scale Resistor. See the Gain section and Figure 32 for value.
15	R <sub>S</sub>	Scale Resistor. See the Gain section and Figure 32 for value.
16	V <sub>IOS</sub> NULL	Input Offset Voltage Null. Connect a 100 k $\Omega$ trimmer across Pin 16 and Pin 17 with wiper to negative supply voltage.
17	V <sub>IOS</sub> NULL	Input Offset Voltage Null. Connect a 100 k $\Omega$ trimmer across Pin 16 and Pin 17 with wiper to negative supply voltage.
18	+IN	Noninverting Signal Input.
19	TEST PIN	Test Pin. Pin 19 is reserved for factory test. Do not connect.
20	R <sub>G</sub>	Gain Resistor Pin. Install a resistor between 200 k $\Omega$ and 100 $\Omega$ to Pin 1.

# TYPICAL PERFORMANCE CHARACTERISTICS

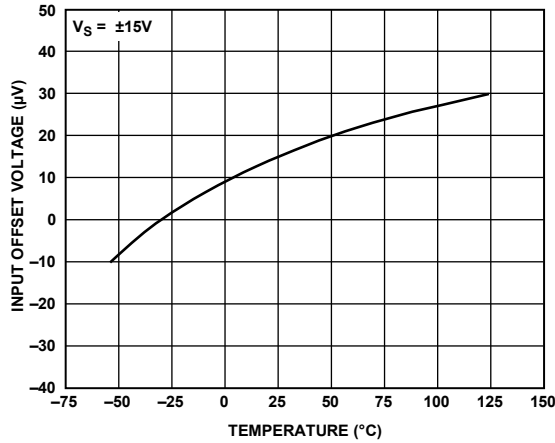

Figure 5. Input Offset Voltage vs. Temperature

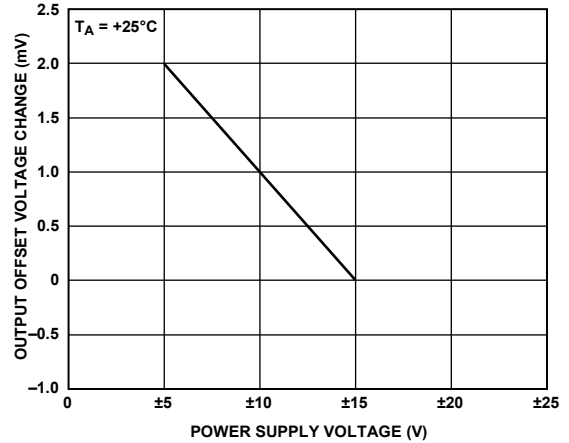

Figure 8. Output Offset Voltage Change vs. Supply Voltage

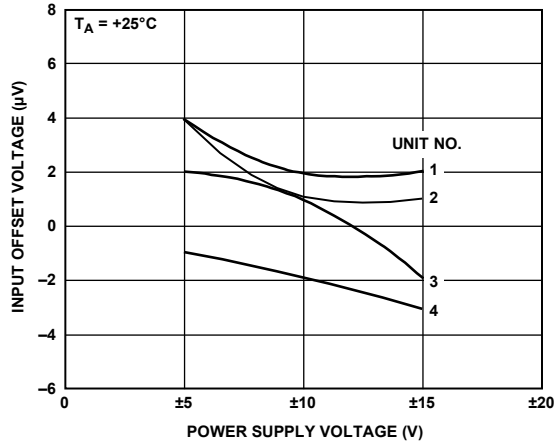

Figure 6. Input Offset Voltage vs. Supply Voltage

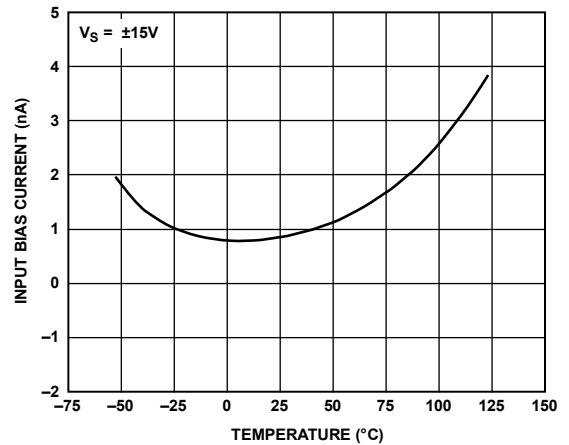

Figure 9. Input Bias Current vs. Temperature

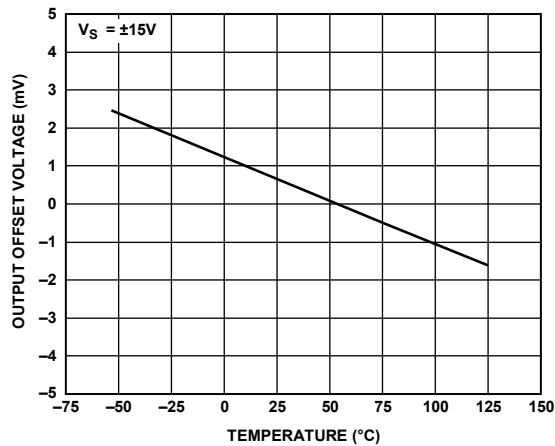

Figure 7. Output Offset Voltage vs. Temperature

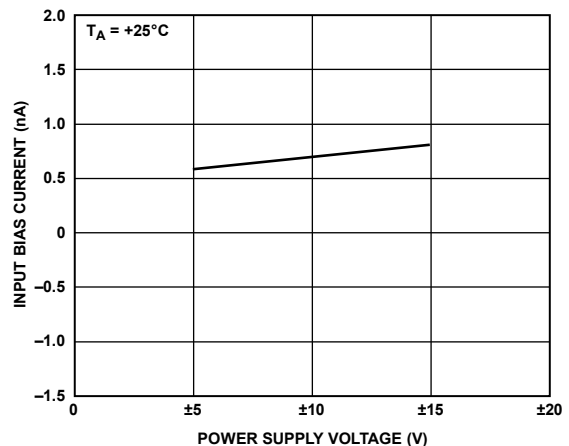

Figure 10. Input Bias Current vs. Supply Voltage

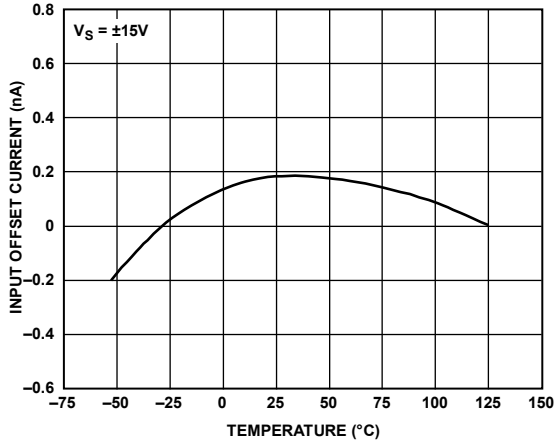

Figure 11. Input Offset Current vs. Temperature

14335-011



Figure 14. Common-Mode Voltage Range vs. Temperature

14335-014

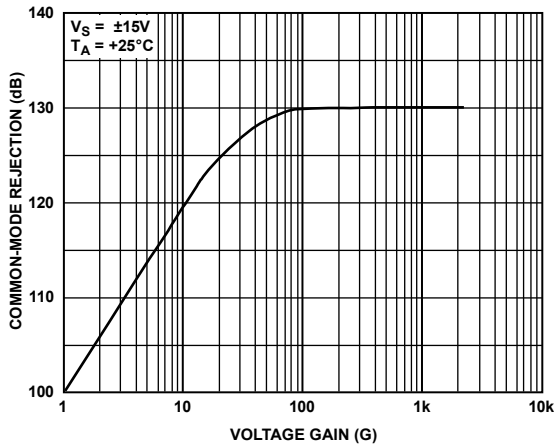

Figure 12. Common-Mode Rejection vs. Voltage Gain

14335-012



Figure 15. Positive Power Supply Rejection (PSR) vs. Frequency

14335-015

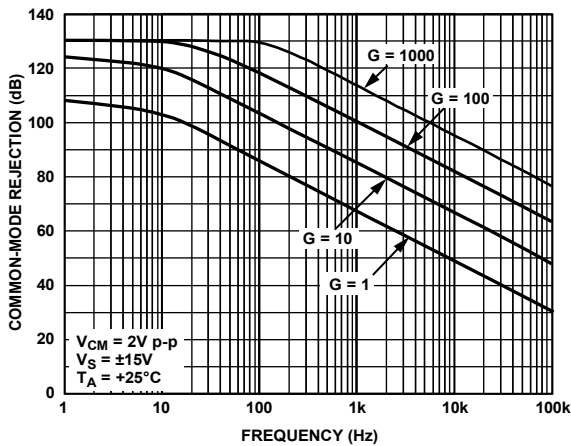

Figure 13. Common-Mode Rejection vs. Frequency

14335-013

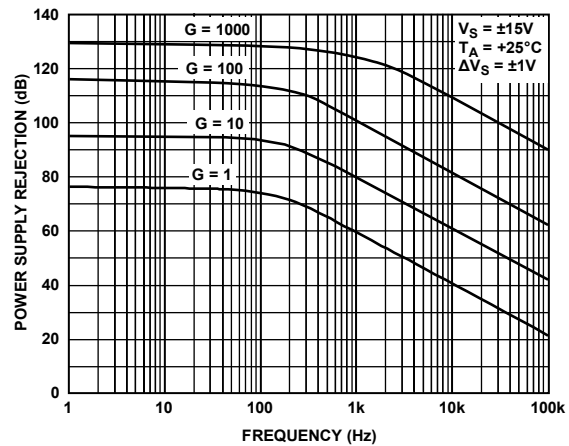

Figure 16. Negative PSR vs. Frequency

14335-016

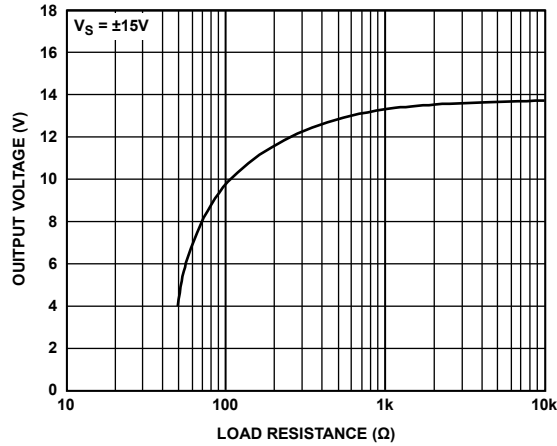

Figure 17. Maximum Output Voltage vs. Load Resistance

14335-017

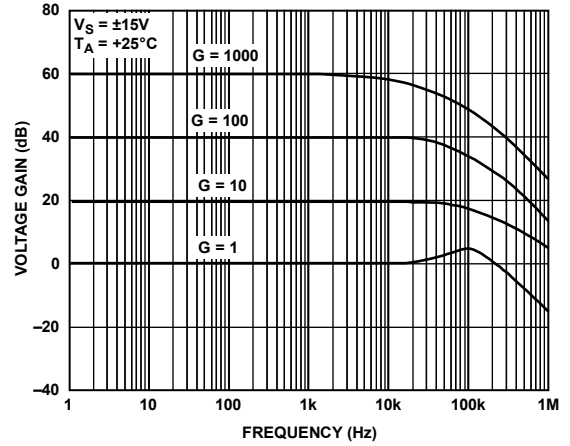

Figure 20. Closed-Loop Voltage Gain vs. Frequency

14335-020

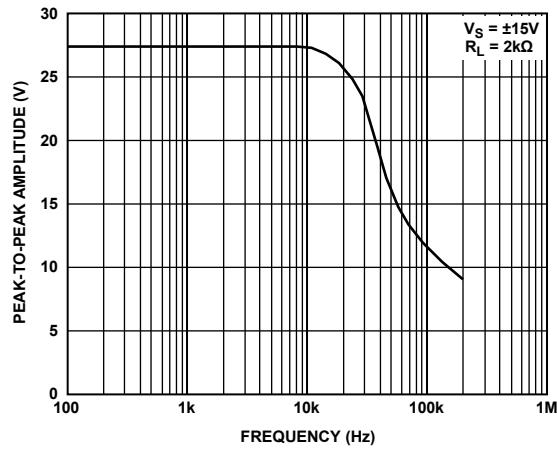

Figure 18. Maximum Output Swing vs. Frequency

14335-018

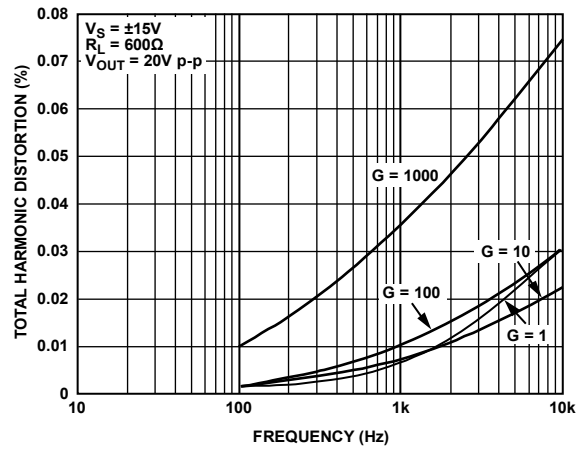

Figure 21. Total Harmonic Distortion vs. Frequency

14335-021

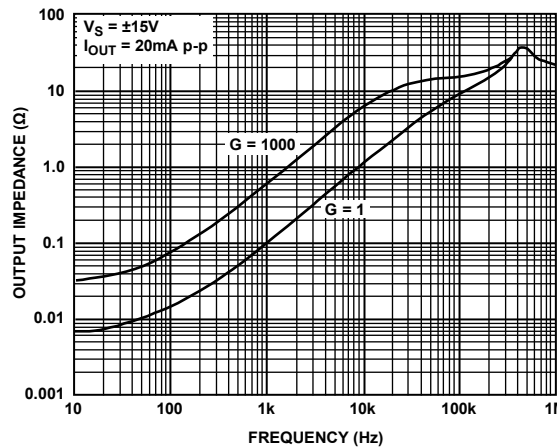

Figure 19. Closed-Loop Output Impedance vs. Frequency

14335-019

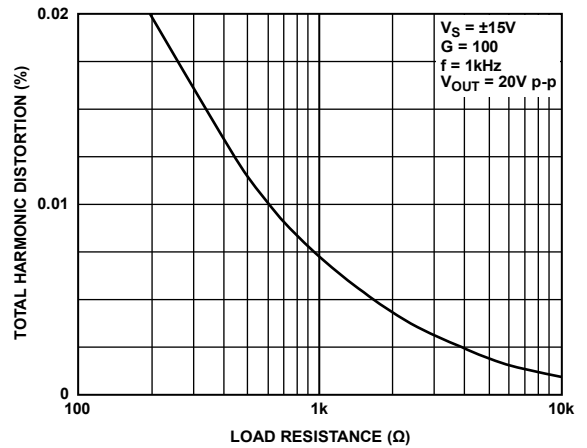

Figure 22. Total Harmonic Distortion vs. Load Resistance

14335-022



Figure 23. Slew Rate vs. Voltage Gain

14335-023



Figure 26. Voltage Noise Density vs. Frequency

14335-026



Figure 24. Slew Rate vs. Load Capacitance

14335-024



Figure 27. RTI Voltage Noise Density vs. Gain

14335-027



Figure 25. Settling Time to 0.01% vs. Voltage Gain

14335-025



Figure 28. Positive Supply Current vs. Supply Voltage

14335-028





Figure 29. Negative Supply Current vs. Supply Voltage

14335-029

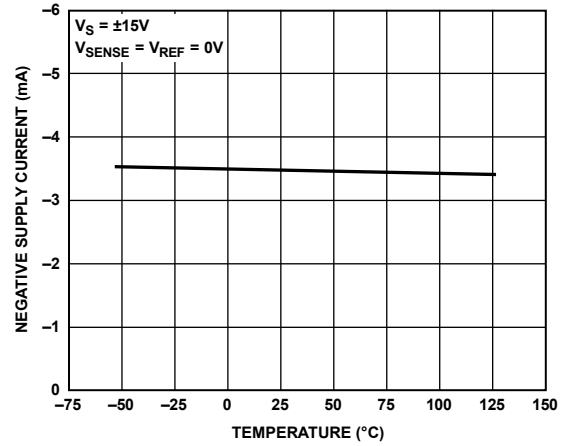

Figure 31. Negative Supply Current vs. Temperature

14335-031

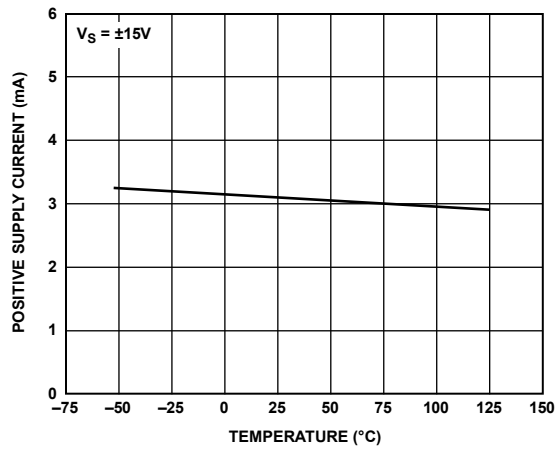

Figure 30. Positive Supply Current vs. Temperature

14335-030

## THEORY OF OPERATION

### INPUT AND OUTPUT OFFSET VOLTAGES

Instrumentation amplifiers have independent offset voltages associated with the input and output stages. Still, temperature variations cause offset shifts regardless of initial zero adjustments. Systems with auto-zero correct for offset errors, rendering initial adjustment unnecessary. However, many high gain applications do not have auto-zero. For such applications, both offsets can be nulled, which has minimal effect on  $TCV_{IOS}$  and  $TCV_{OOS}$ .

The input offset component is directly multiplied by the amplifier gain, whereas output offset is independent of gain. Therefore, at low gain, output offset errors dominate, whereas at high gain, input offset errors dominate. The overall offset voltage,  $V_{OS}$ , referred to the output (RTO) is calculated as follows:

$$V_{OS} (RTO) = (V_{IOS} \times G) + V_{OOS} \quad (1)$$

where:

$V_{IOS}$  is the input offset voltage specification.

$V_{OOS}$  is the output offset voltage specification.

$G$  is the amplifier gain.

Input offset nulling alone is recommended with amplifiers having fixed gain above 50. Output offset nulling alone is recommended when gain is fixed at 50 or below.

In applications requiring both initial offsets to be nulled, the input offset is nulled first by short circuiting  $R_G$ , then the output offset is nulled with the short removed.

The overall offset voltage drift,  $TCV_{OS}$ , referred to the output is a combination of input and output drift specifications. Input offset voltage drift is multiplied by the amplifier gain,  $G$ , and summed with the output offset drift:

$$TCV_{OS} (RTO) = (TCV_{IOS} \times G) + TCV_{OOS} \quad (2)$$

where:

$TCV_{IOS}$  is the input offset voltage drift.

$TCV_{OOS}$  is the output offset voltage specification.

Frequently, the amplifier drift is referred back to the input (RTI), which is then equivalent to an input signal change:

$$TCV_{OS} (RTI) = TCV_{IOS} \frac{TCV_{OOS}}{G} \quad (3)$$

For example, the maximum input referred drift of an AMP01EX set to  $G = 1000$  becomes,

$$TCV_{OS} (RTI) = 0.3 \mu V/^{\circ}C + \frac{100 \mu V/^{\circ}C}{1000} = 0.4 \mu V/^{\circ}C \text{ max}$$

### INPUT BIAS AND OFFSET CURRENTS

Input transistor bias currents are additional error sources that can degrade the input signal. Bias currents flowing through the signal source resistance appear as an additional offset voltage. Equal source resistance on both inputs of an instrumentation amplifier (IA) minimizes offset changes due to bias current variations with signal voltage and temperature. However, the difference between the two bias currents, the input offset current, produces a nontrimmable error. The magnitude of the error is the offset current times the source resistance.

A current path must always be provided between the differential inputs and analog ground to ensure correct amplifier operation. Floating inputs, such as thermocouples, must be grounded close to the signal source for best common-mode rejection.

### GAIN

The AMP01 uses two external resistors for setting voltage gain over the range of 0.1 to 10,000. The magnitudes of the scale resistor,  $R_S$ , and the gain set resistor,  $R_G$ , are related by the formula  $G = 20 \times R_S/R_G$ , where  $G$  is the selected voltage gain (see Figure 32).



Figure 32. Basic AMP01 Connections for Gains of 0.1 to 10,000

The magnitude of  $R_S$  affects linearity and output referred errors. Circuit performance is characterized using  $R_S = 10 \text{ k}\Omega$  when operating on  $\pm 15 \text{ V}$  supplies and driving a  $\pm 10 \text{ V}$  output.  $R_S$  can be reduced to  $5 \text{ k}\Omega$  in many applications, particularly when operating on  $\pm 5 \text{ V}$  supplies, or if the output voltage swing is limited to  $\pm 5 \text{ V}$ . Bandwidth is improved with  $R_S = 5 \text{ k}\Omega$ , increasing the common-mode rejection by approximately 6 dB at low gain. Reducing the value below  $5 \text{ k}\Omega$  can cause instability in some circuit configurations and usually has no advantage. High voltage gains between 2 and 10,000 require very low values of  $R_G$ . For  $R_S = 10 \text{ k}\Omega$  and  $A_V = 2000$ ,  $R_G = 100 \Omega$ ; this value is the practical lower limit for  $R_G$ . Below  $100 \Omega$ , mismatch of wire bond and resistor temperature coefficients (TCs) introduce significant gain TC errors. Therefore, for gains above 2000,  $R_G$  must be kept constant at  $100 \Omega$  and  $R_S$  increased. The maximum gain of 10,000 is obtained with  $R_S$  set to  $50 \text{ k}\Omega$ .

Metal film or wire wound resistors are recommended for best results. The absolute values and TCs are not too important, only the ratiometric parameters.

AC amplifiers require good gain stability with temperature and time, but dc performance is unimportant. Therefore, low cost metal film types with TCs of 50 ppm/°C are usually adequate for  $R_S$  and  $R_G$ . Realizing the full potential of the offset voltage and gain stability of the AMP01 requires precision metal film or wire wound resistors. Achieving a 15 ppm/°C gain TC at all gains requires  $R_S$  and  $R_G$  temperature coefficient matching to 5 ppm/°C or better.



Figure 33.  $R_G$  and  $R_S$  Selection

Gain accuracy is determined by the ratio accuracy of  $R_S$  and  $R_G$  combined with the gain equation error of the AMP01 (0.6% maximum for A and E grades).

All instrumentation amplifiers require attention to layout so that thermocouple effects are minimized. Thermocouples formed between copper and dissimilar metals can destroy the  $TCV_{OS}$  performance of the AMP01, which is typically 0.15  $\mu V/^\circ C$ . Resistors themselves can generate thermoelectric EMFs when mounted parallel to a thermal gradient. Vishay resistors are recommended because a maximum value for thermoelectric generation is specified. However, where thermal gradients are low and gain TCs of 20 ppm to 50 ppm are sufficient, general-purpose metal film resistors can be used for  $R_G$  and  $R_S$ .

### COMMON-MODE REJECTION

Ideally, an instrumentation amplifier responds only to the difference between the two input signals and rejects common-mode voltages and noise. In practice, there is a small change in output voltage when both inputs experience the same common-mode voltage change; the ratio of these voltages is called the common-mode gain. Common-mode rejection (CMR) is the logarithm of the ratio of differential-mode gain to common-mode gain, expressed in dB. CMR specifications are normally measured with a full-range input voltage change and a specified source resistance unbalance.

The current feedback design used in the AMP01 inherently yields high common-mode rejection. Unlike resistive feedback designs, typified by the 3-op-amp IA, the CMR is not degraded

by small resistances in series with the reference input. A slight but trimmable output offset voltage change results from resistance in series with the reference input.

The common-mode input voltage range (CMVR) for linear operation can be calculated from the formula,

$$CMVR = \pm \left( IVR - \frac{|V_{OUT}|}{2G} \right) \quad (4)$$

where:

$IVR$  is the data sheet specification for the input voltage range.

$V_{OUT}$  is the maximum output signal.

$G$  is the chosen voltage gain.

For example, at 25°C,  $IVR$  is specified as  $\pm 10.5$  V minimum with  $\pm 15$  V supplies. Using a  $\pm 10$  V maximum swing output and substituting the figures in Equation 4 simplifies the formula to

$$CMVR = \pm \left( 10.5 - \frac{5}{G} \right) \quad (5)$$

For all gains greater than or equal to 10, CMVR is  $\pm 10$  V minimum; at gains below 10, CMVR is reduced.

### ACTIVE GUARD DRIVE

Rejection of common-mode noise and line pickup can be improved by using shielded cable between the signal source and the IA. Shielding reduces pickup, but increases input capacitance, which in turn degrades the settling-time for signal changes. Furthermore, any imbalance in the source resistance between the inverting and noninverting inputs, when capacitively loaded, converts the common-mode voltage into a differential voltage. This effect reduces the benefits of shielding. AC common-mode rejection is improved by bootstrapping the input cable capacitance to the input signal, a technique called guard driving. This technique effectively reduces the input capacitance. A single guard-driving signal is adequate at gains above 100 and must be the average value of the two inputs. The value of the external gain resistor,  $R_G$ , is split between two resistors,  $R_{G1}$  and  $R_{G2}$ ; the center tap provides the required signal to drive the buffer amplifier (see Figure 34).

### GROUNDING

The majority of instruments and data acquisition systems have separate grounds for analog and digital signals. Analog ground can also be divided into two or more grounds that are tied together at one point, usually the analog power-supply ground. In addition, the digital and analog grounds can be joined, normally at the analog ground pin on the analog-to-digital converter (ADC). Following this basic grounding practice is essential for good circuit performance (see Figure 35).

Mixing grounds causes interactions between digital circuits and the analog signals. Because the ground returns have finite resistance and inductance, hundreds of millivolts can be developed between the system ground and the data acquisition components. Using separate ground returns minimizes the current flow in the sensitive analog return path to the system

ground point. Consequently, noisy ground currents from logic gates do not interact with the analog signals.

Inevitably, two or more circuits are joined together with their grounds at differential potentials. In these situations, the differential input of an instrumentation amplifier, with its high CMR, can accurately transfer analog information from one circuit to another.

**SENSE AND REFERENCE TERMINALS**

The sense terminal completes the feedback path for the instrumentation amplifier output stage and is normally connected directly to the output. The output signal is specified with respect to the reference terminal, which is normally connected to analog ground.



Figure 34. AMP01 Evaluation Circuit Showing Guard-Drive Connection



Figure 35. Basic Grounding Practice

If heavy output currents are expected and the load is situated some distance from the amplifier, voltage drops due to track or wire resistance cause errors. Voltage drops are particularly troublesome when driving 50 Ω loads. Under these conditions, the sense and reference terminals can be used to remote sense the load, as shown in Figure 36. This method of connection puts the  $I \times R$  drops inside the feedback loop and virtually eliminates the error. An unbalance in the lead resistances from the sense and reference pins does not degrade CMR, but does change the output offset voltage. For example, a large unbalance of 3 Ω changes the output offset by only 1 mV.

**DRIVING 50 Ω LOADS**

Output currents of 50 mA are guaranteed into loads of up to 50 Ω and 26 mA into 500 Ω. In addition, the output is stable and free from oscillation even with a high load capacitance. The combination of these unique features in an instrumentation amplifier allows low level transducer signals to be conditioned and directly transmitted through long cables in voltage or current form. Increased output current brings increased internal dissipation, especially with 50 Ω loads. For this reason, the power-supply connections are split into two pairs; Pin 10 and Pin 13 connect to the output stage only, and Pin 11 and Pin 12 provide power to the input and following stages. Dual supply pins allow dropper resistors to be connected in series with the output stage so excess power is dissipated outside the package. Additional decoupling is necessary between Pin 10 and Pin 13 to ground to maintain stability when dropper resistors are used. Figure 37 shows a complete circuit for driving 50 Ω loads.



Figure 36. Remote Load Sensing

14335-036

POWER BANDWIDTH, G = 100, 130kHz  
 POWER BANDWIDTH, G = 10, 200kHz  
 THD: ~0.04% AT 1kHz, 2V rms



Figure 37. Driving 50 Ω Loads

14335-037

## HEATSINKING

To maintain high reliability, the die temperature of any IC must be kept as low as practicable, preferably below 100°C. Although most AMP01 application circuits produce very little internal heat—little more than the quiescent dissipation of 90 mW—some circuits raise that to several hundred milliwatts (for example, the 4 mA to 20 mA current transmitter application; see Figure 40). Excessive dissipation causes thermal shutdown of the output stage, thus protecting the device from damage. A heatsink is recommended in power applications to reduce the die temperature.

Several appropriate heatsinks are available; the Thermalloy 6010B is especially easy to use and is inexpensive. Intended for dual-in-line packages, the heatsink can be attached with a cyanoacrylate adhesive. This heatsink reduces the thermal resistance between the junction and ambient environment to approximately 80°C/W. Junction (die) temperature can then be calculated by using the following relationship:

$$P_d = \frac{T_J - T_A}{\theta_{JA}}$$

where:

$P_d$  is the internal dissipation of the device.

$T_J$  is the junction temperature.

$T_A$  is the ambient temperature.

$\theta_{JA}$  is the thermal resistance from junction to ambient.

## OVERVOLTAGE PROTECTION

Instrumentation amplifiers invariably sit at the front end of instrumentation systems where there is a high probability of exposure to overloads. Voltage transients, failure of a transducer, or removal of the amplifier power supply while the signal source is connected can destroy or degrade the performance of an unprotected amplifier. Although it is impractical to protect an IC internally against connection to power lines, it is relatively easy to provide protection against typical system overloads.

The AMP01 is internally protected against overloads for gains of up to 100. At higher gains, the protection is reduced and some external measures may be required. Limited internal overload protection is used so that noise performance is not significantly degraded.

AMP01 noise level approaches the theoretical noise floor of the input stage, which is 4 nV/√Hz at 1 kHz when the gain is set at 1000. Noise is the result of shot noise in the input devices and Johnson noise in the resistors. Resistor noise is calculated from the values of  $R_G$  (200 Ω at a gain of 1000) and the input protection resistors (250 Ω). Active loads for the input transistors contribute less than 1 nV/√Hz of noise. The measured noise level is typically 5 nV/√Hz.

Diodes across the input transistor's base-emitter junctions, combined with 250 Ω input resistors and  $R_G$ , protect against differential inputs of up to ±20 V for gains of up to 100. The diodes also prevent avalanche breakdown that degrade the  $I_B$  and  $I_{OS}$  specifications. Decreasing the value of  $R_G$  for gains above 100 limits the maximum input overload protection to ±10 V.

External series resistors can be added to guard against higher voltage levels at the input, but resistors alone increase the input noise and degrade the signal-to-noise ratio, especially at high gains.

Protection can also be achieved by connecting back to back 9.1 V Zener diodes across the differential inputs. This technique does not affect the input noise level and can be used down to a gain of 2 with minimal increase in input current. Although voltage-clamping elements look like short circuits at the limiting voltage, the majority of signal sources provide less than 50 mA, producing power levels that are easily handled by low power Zener diodes.

Simultaneous connection of the differential inputs to a low impedance signal above 10 V during normal circuit operation is unlikely. However, additional protection involves adding 100 Ω current-limiting resistors in each signal path prior to the voltage clamp, the resistors increase the input noise level to just 5.4 nV/√Hz (refer to Figure 38).

Input components, whether multiplexers or resistors, should be carefully selected to prevent the formation of thermocouple junctions that would degrade the input signal.



Figure 38. Input Overvoltage Protection for Gains of 2 to 10,000

## POWER SUPPLY CONSIDERATIONS

Achieving the rated performance of precision amplifiers in a practical circuit requires careful attention to external influences. For example, supply noise and changes in the nominal voltage directly affect the input offset voltage. A PSR of 80 dB means that a change of 100 mV on the supply produces a 10 μV input offset change. Consequently, care must be taken in choosing a power source with low output noise, good line and load regulation, and good temperature stability.

APPLICATIONS CIRCUITS



Figure 39. High Compliance Bipolar Current Source with 13-Bit Linearity

14335-039

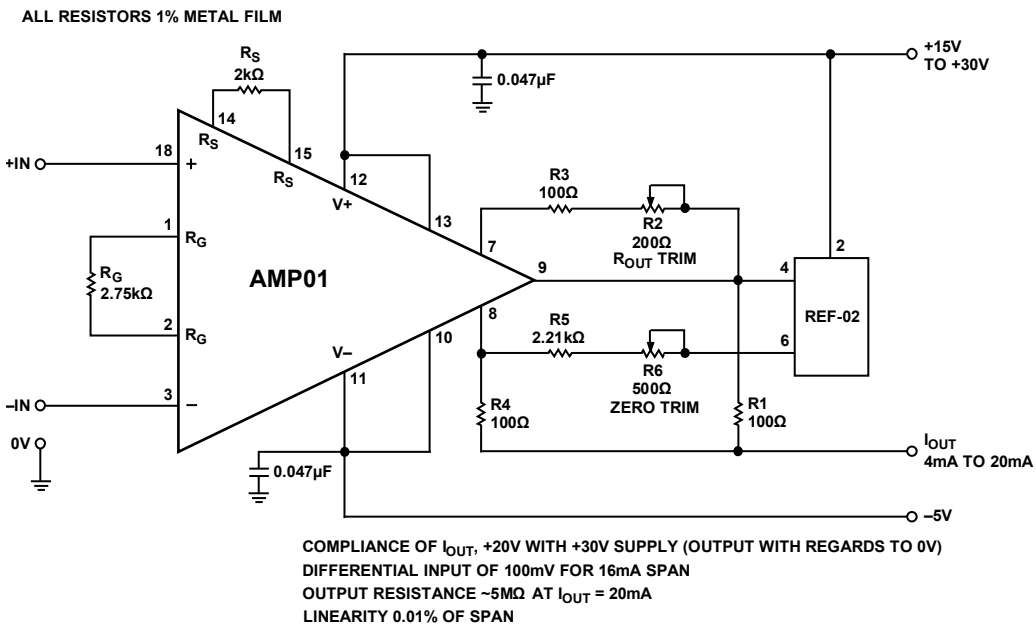

Figure 40. 13-Bit Linear 4 mA to 20 mA Transmitter Constructed by Adding a Voltage Reference; Thermocouple Signals can be Accepted Without Preamplification

14335-040

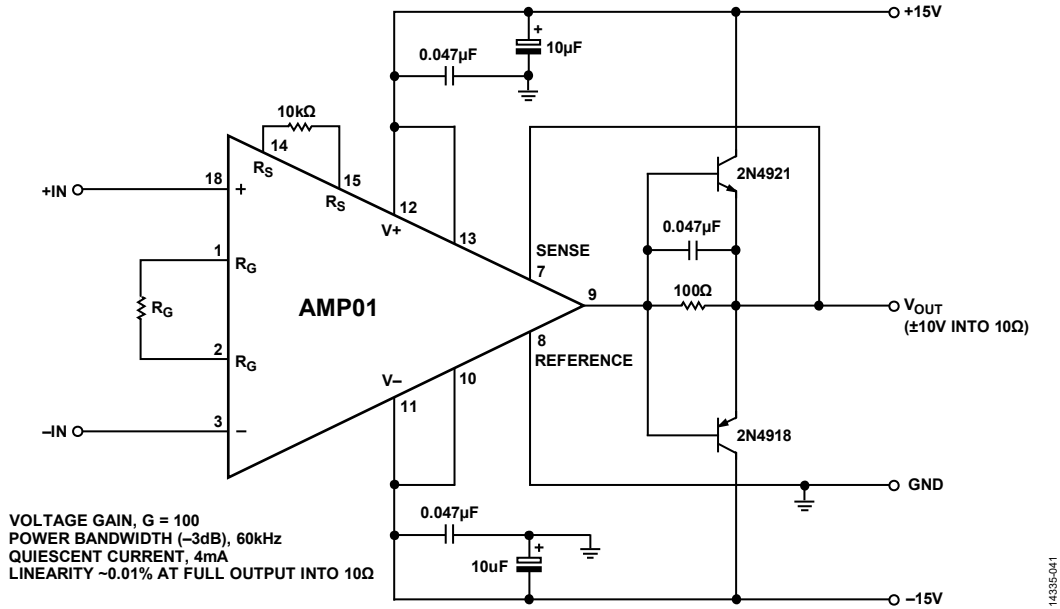

Figure 41. Adding Two Transistors Increases Output Current to  $\pm 1$  A Without Affecting the Quiescent Current of 4 mA; Power Bandwidth is 60 kHz



Figure 42. AMP01 Makes an Excellent Programmable-Gain Instrumentation Amplifier; Combined Gain-Switching and Settling Time to 13 Bits Falls Below 100  $\mu$ s; Linearity is Better than 12 Bits over a Gain Range of 1 to 1000



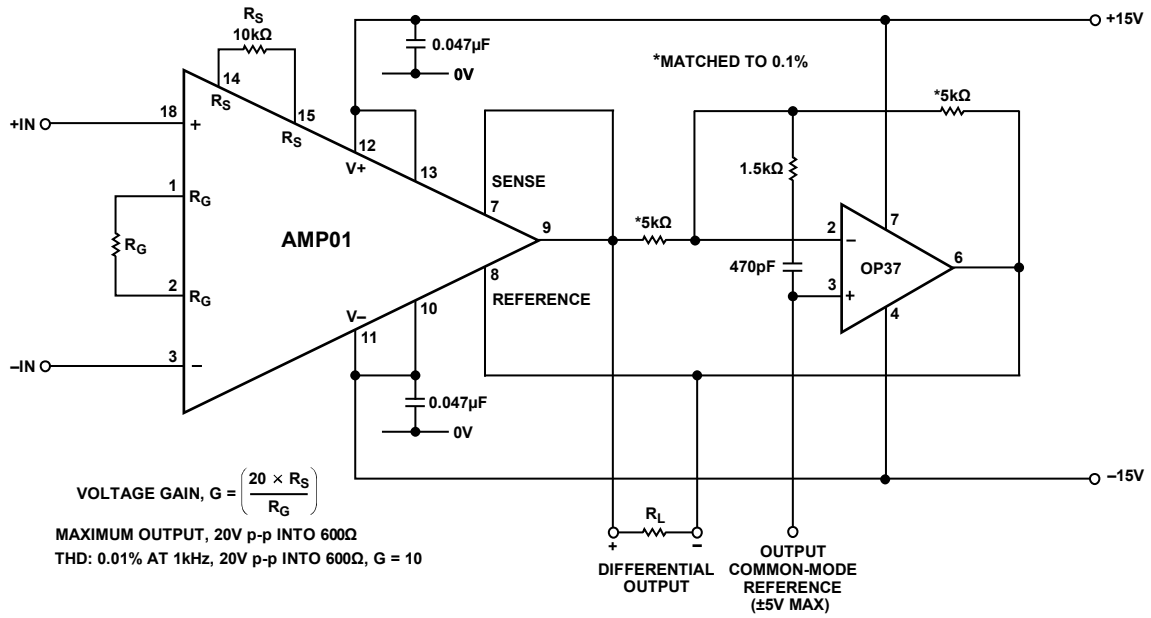

Figure 43. A Differential Input Instrumentation Amplifier with Differential Output Replaces a Transformer in Many Applications; Output Drives a 600Ω Load at Low Distortion (0.01%)

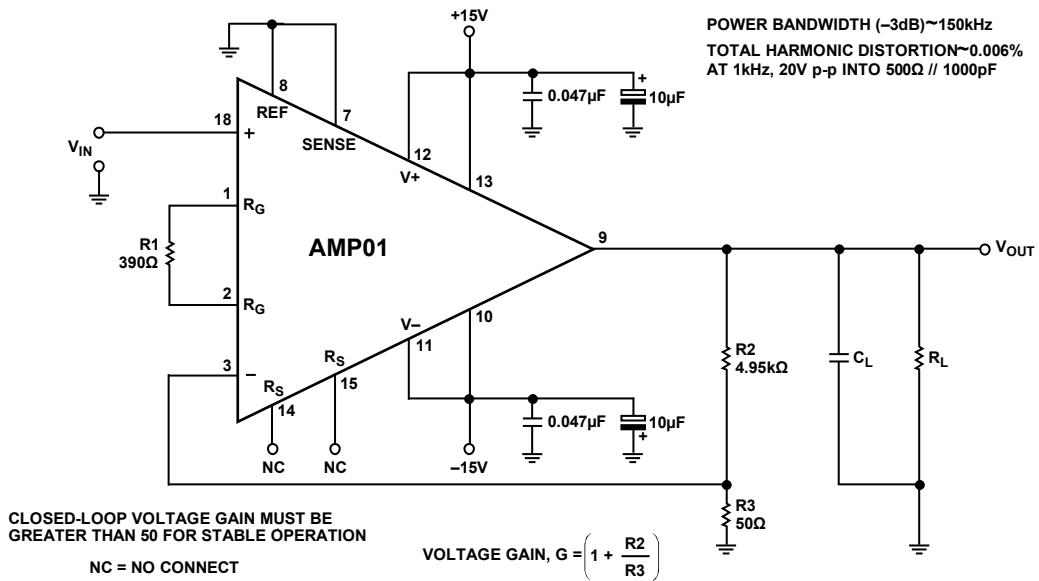

Figure 44. Configuring the AMP01 as a Noninverting Operational Amplifier Provides Exceptional Performance; Output Handles Low Load Impedances at Very Low Distortion (0.006%)



Figure 45. Inverting Operational Amplifier Configuration has Excellent Linearity over the Gain Range 1 to 1000, Typically 0.005%; Offset Voltage Drift at Unity Gain is Improved over the Drift in the Instrumentation Amplifier Configuration



Figure 46. Stability with Large Capacitive Loads Combined with High Output Current Capability Make the AMP01 Ideal for Line Driving Applications; Offset Voltage Drift Approaches the  $TCV_{ios}$  Limit ( $0.3 \mu\text{V}/^\circ\text{C}$ )



Figure 47. Noise Test Circuit (0.1 Hz to 10 Hz)

14335-047

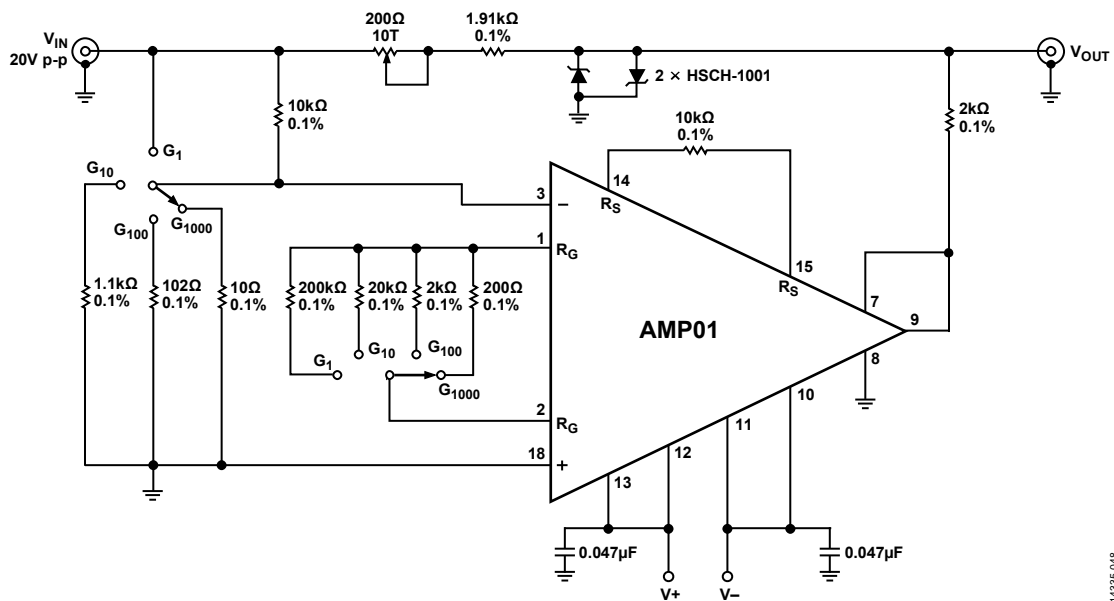

Figure 48. Settling Time Test Circuit

14335-048

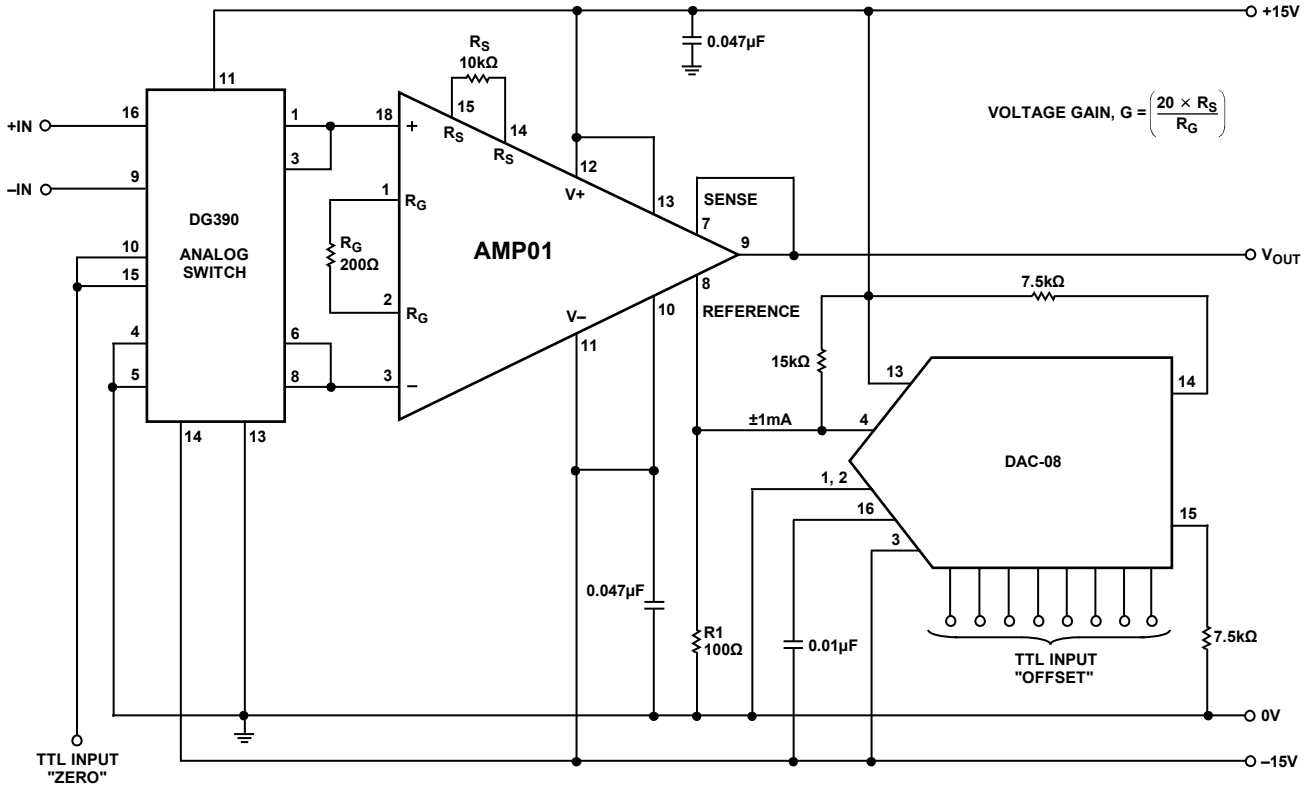

Figure 49. Instrumentation Amplifier with Auto-Zero

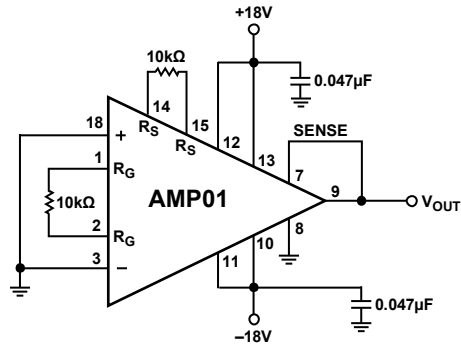

Figure 50. Burn-In Circuit