

SERIES: AMT10 | **DESCRIPTION:** MODULAR INCREMENTAL ENCODER

FEATURES

- patented capacitive ASIC technology
- low power consumption
- CMOS outputs
- 16 DIP switch selectable resolutions
- index pulse
- modular package design
- straight (radial) and right-angle (axial) versions
- 9 mounting hole options for radial version
- 8 mounting hole options for axial version
- -40-100°C operating temperature

ELECTRICAL

| parameter | conditions/description | min | typ | max | units |
|---------------------|------------------------------|---------|-----|-----|-------|
| power supply | VDD | 3.6 | 5 | 5.5 | V |
| current consumption | with unloaded output | | 6 | | mA |
| output high level | | VDD-0.8 | | | V |
| output low level | | | | 0.4 | V |
| output current | CMOS sink/source per channel | | | 2 | mA |
| rise/fall time | | | 30 | | ns |

INCREMENTAL CHARACTERISTICS

| parameter | conditions/description | min | typ | max | units |
|--|---|-----|------|-----|---------|
| channels | quadrature A, B, and X index | | | | |
| waveform | CMOS voltage square wave | | | | |
| phase difference | A leads B for CCW rotation (viewed from front) | | 90 | | degrees |
| quadrature resolutions ¹ | 48, 96, 100, 125, 192, 200, 250, 256, 384, 400, 500, 512, 800, 1000, 1024, 2048 | | | | PPR |
| index ² | one pulse per 360 degree rotation | | | | |
| accuracy | | | 0.25 | | degrees |
| quadrature duty cycle (at each resolution) | 256, 512, 1024, 2048 | 49 | 50 | 51 | % |
| | 48, 96, 100, 125, 192, 200, 250, 384, 400, 500 | 47 | 50 | 53 | % |
| | 800, 1000 | 43 | 50 | 56 | % |

Notes: 1. Resolution selected via adjustable DIP switch, pre-set to 2048 PPR. All resolutions are listed as pre-quadrature, meaning the final number of counts is PPR x 4.
2. Some stepper motors may leak a magnetic field causing the AMT index pulse to not function properly (non-magnetic version available with 8 pulses per revolution).

MECHANICAL

| parameter | conditions/description | min | typ | max | units |
|---------------------------------------|---|-----|---------------|---------------|------------|
| motor shaft length | | 9 | | | mm |
| motor shaft tolerance | | | NOM +0/-0.015 | | mm |
| weight | AMT102 AMT103 | | 20.5 14.0 | | g g |
| axial play | | | | ±0.3 | mm |
| rotational speed (at each resolution) | 192, 384, 400, 500, 800, 1000, 1024, 2048 48, 96, 100, 125, 200, 250, 256, 512 | | | 7500 15000 | RPM RPM |

ENVIRONMENTAL

| parameter | conditions/description | min | typ | max | units |
|------------------------------------|-------------------------------|-----|-----|-----|-------|
| operating temperature ¹ | | -40 | | 100 | °C |
| humidity | non-condensing | | | 95 | % |
| vibration | 20~500 Hz, 1 hour on each XYZ | | | 10 | G |
| shock | 11 ms, ±XYZ direction | | | 50 | G |
| RoHS | yes | | | | |

Note: ¹ Encoders with operating temperature of -40~125°C are available as a custom order

WAVEFORMS

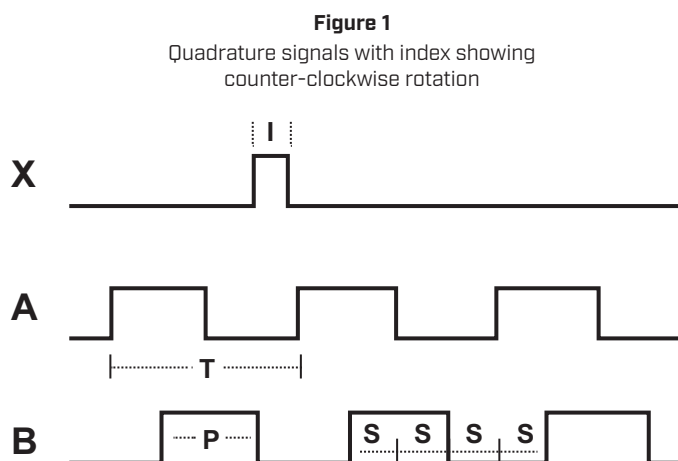

The following parameters are defined by the resolution selected for each encoder. The encoders resolution is listed as Pulses Per Revolution (PPR), which is the number of periods (or high pulses) over the encoders revolution.

| Parameter | Description | Expression | Units | Notes |
|-----------|-----------------|------------|-----------------------|--|
| PPR | resolution | | Pulses Per Revolution | This is the user selected value and the format all resolutions are listed in |
| CPR | counts | PPR x 4 | Counts Per Revolution | This is the number of quadrature counts the encoder has |
| T | period | 360/R | mechanical degrees | |
| P | pulse width | T/2 | mechanical degrees | |
| S | A/B state width | T/4 | mechanical degrees | This is the width of a quadrature state |
| I | index width | T/4 | mechanical degrees | The width of a once per turn index is the state width for A & B lines |

Note: For more information regarding PPR, CPR, or LPR (Lines Per Revolution) view <https://www.cuidevices.com/blog/what-is-encoder-ppr-cpr-and-lpr>

PART NUMBER KEY

For customers that prefer a specific AMT10 configuration, please reference the custom configuration key below.



Note: 1. Fixed resolutions are permanently set at this value; adjustable resolutions are preset via DIP switch to this value upon shipment.

AMT10-V KITS

In order to provide maximum flexibility for our customers, the AMT10 series is provided in kit form standard. This allows the user to implement the encoder into a range of applications using one sku#, reducing engineering and inventory costs.

ORDERING GUIDE

AMT10X-V

Orientation:
2 = Radial
3 = Axial
*See Mechanical Drawings

| SLEEVES | | | | | | | | |
|---------|-------------------|-----|-------|--------------------|------|--------------------|--------|----------------|
| | | | | | | | | |
| 8mm | 1/4 inch (6.35mm) | 6mm | 5mm | 3/16 inch (4.76mm) | 4mm | 1/8 inch (3.175mm) | 3mm | 2mm |
| Blue | Snow | Red | Green | Yellow | Gray | Purple | Orange | Light Sky Blue |

| | | | |
|--------------|-------------------|-------------------|-------------------|
| 102 BASE | 102 WIDE BASE | 102 TOP COVER | SHAFT ADAPTER |
| 103 BASE | 103 TOP COVER | TOOL A | TOOL B |

RESOLUTION SETTINGS

1 = On, 0 = Off

| Resolution (PPR) | Maximum RPM | 1 | 2 | 3 | 4 |
|------------------|-------------|---|---|---|---|
| 2048 | 7500 | 0 | 0 | 0 | 0 |
| 1024 | 7500 | 0 | 0 | 1 | 0 |
| 1000 | 7500 | 1 | 0 | 0 | 0 |
| 800 | 7500 | 0 | 1 | 0 | 0 |
| 512 | 15000 | 0 | 0 | 0 | 1 |
| 500 | 7500 | 1 | 0 | 1 | 0 |
| 400 | 7500 | 0 | 1 | 1 | 0 |
| 384 | 7500 | 1 | 1 | 0 | 0 |
| 256 | 15000 | 0 | 0 | 1 | 1 |
| 250 | 15000 | 1 | 0 | 0 | 1 |
| 200 | 15000 | 0 | 1 | 0 | 1 |
| 192 | 7500 | 1 | 1 | 1 | 0 |
| 125 | 15000 | 1 | 0 | 1 | 1 |
| 100 | 15000 | 0 | 1 | 1 | 1 |
| 96 | 15000 | 1 | 1 | 0 | 1 |
| 48 | 15000 | 1 | 1 | 1 | 1 |

DIP switch:
Example setting: 500 PPR



ENCODER INTERFACE

| PINOUT CONNECTOR | | |
|------------------|---------------|---------------|
| Function | | |
| # | AMT102 | AMT103 |
| B | B CHANNEL | B CHANNEL |
| 5V | +5 V | +5 V |
| A | A CHANNEL | A CHANNEL |
| X | INDEX CHANNEL | INDEX CHANNEL |
| G | GND | GND |
| T | UNUSED | N/A |

AMT102



Mating Connector:
Molex 50-57-9405 Housing
Molex 16-02-0086 Terminals

AMT103



Mating Connector:
AMP 3-640440-5 (tin)
AMP 3-641237-5 (gold)

MECHANICAL DRAWING

AMT102

units: mm[inch]
tolerance: ±0.1mm



AMT102 WIDE BASE

units: mm[inch]
tolerance: ±0.1mm

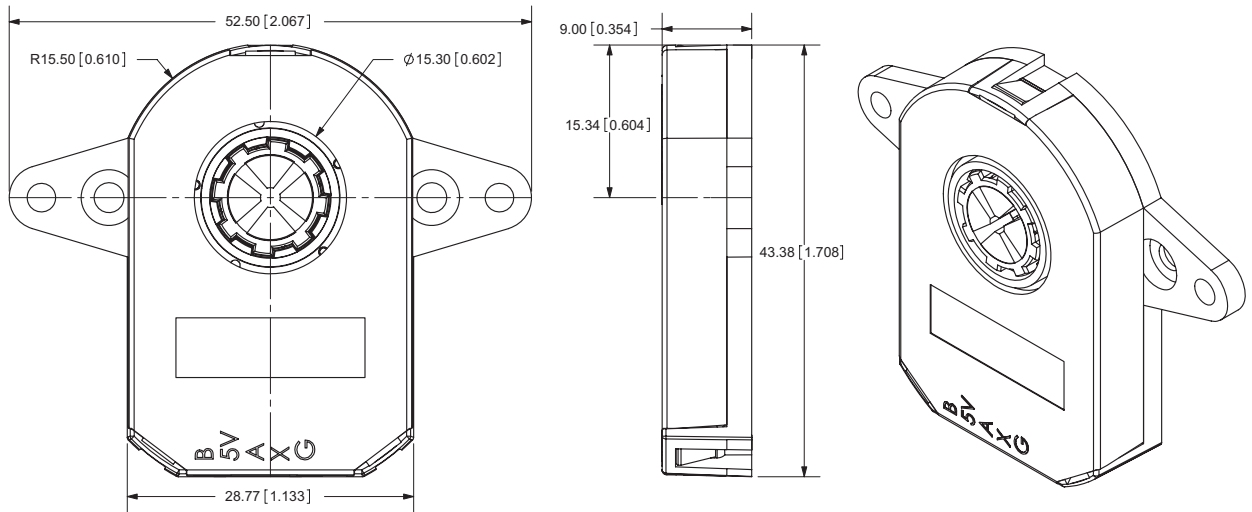

AMT103

units: mm[inch]
tolerance: ±0.1mm

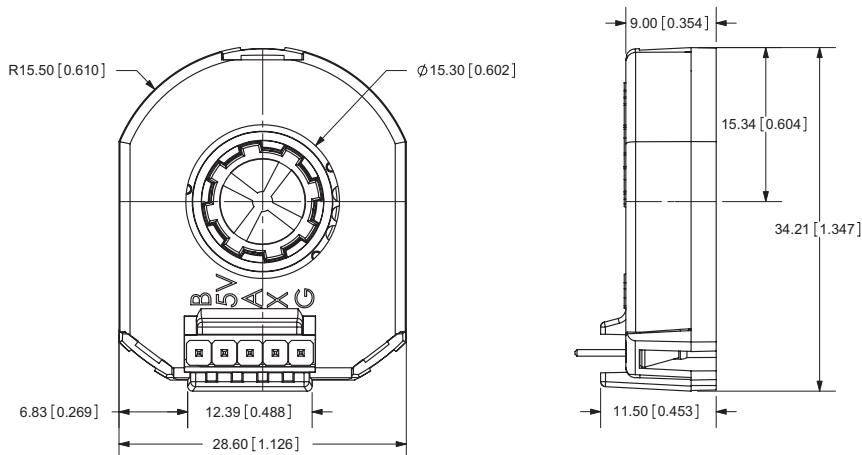

MECHANICAL DRAWING (CONTINUED)

MOUNTING HOLE PATTERNS

AMT102

units: mm[inch]
tolerance: ±0.1mm



AMT102 WIDE BASE

units: mm[inch]
tolerance: ±0.1mm



AMT103

units: mm[inch]
tolerance: ±0.1mm



ASSEMBLY PROCEDURE

STEP 1



1. Insert Tool A as a spacer that defines the distance to the mounting surface.
2. Slide appropriate sized Sleeve over shaft all the way down to Tool A.
3. Slide Shaft Adaptor over Sleeve.
4. Use Tool B to press Shaft Adaptor over Sleeve until flush with Tool A.

STEP 2



1. Remove Tools A and B.
2. Place Base on motor, with Tool B used as a centering tool.

STEP 3



1. Align Tool B with flange on Base.
2. Slide Base and Tool B onto motor, centering onto the Shaft Adapter.

STEP 4



1. Fasten the Base on the motor.
2. Remove Tool B.

STEP 5



1. Slide the Top Cover onto the Base, carefully observing that the teeth of the Shaft Adaptor align with the grooves in the hub.*

* We recommend no more than three cycles of mounting and removal of the AMT top cover base. Multiple cycles of mounting and removing the top cover can cause base fatigue over time and affect encoder performance.

STEP 6



1. Make sure the snaps are fully engaged and the Top Cover is flush with the Base.
2. When assembly is finished, the Shaft Adaptor should be about flush with the front of the Encoder and the Motor Shaft should rotate freely.