

2.4GHz Mini-Stubby Antenna

Features

- 1/4 Wave Monopole Antenna
- 21mm long
- Rugged Flexible Plastic Finish.
- VSWR ≤ 2.0
- Omni-Directional Design
- 50ohm Impedance
- SMA-Plug Fixing
- Nominal Gain 0dBi
- Available as Straight or R/A
- Operating Temp -20 to $+60^{\circ}\text{C}$
- Insulation resistance $500\text{M}\Omega$ @ 500Vdc



Applications

- WiFi Applications
- General Low Power Radio
- M2M Applications

Ordering Information

PART No	Description
ANT-24G-S21-SMA	Stubby Antenna straight SMA
ANT-24G-S21-SMAR	Stubby Antenna R/A SMA
ANT-24G-S21-SMP	Stubby Antenna straight SMA Reverse Polarity
ANT-24G-S21-SMRP	Stubby Antenna R/A SMA Reverse Polarity

ANT-24G-S21-SMA 'Straight' Mechanical Data

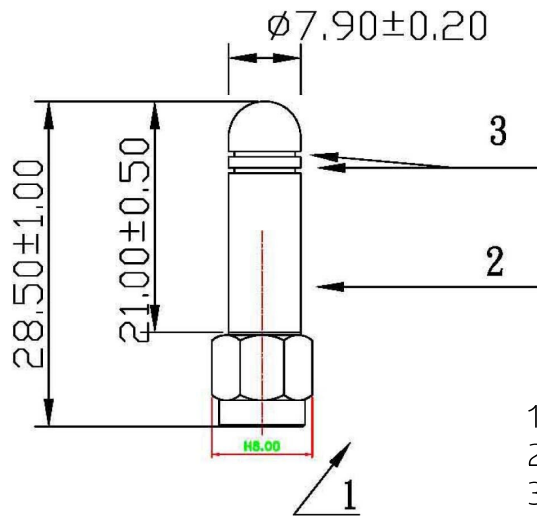

1. SMA Connector : Gold Plated Brass
2. Antenna Cover: Black TPU
3. Identification Stripes

Test Setup for Measurements

Characteristics for this antenna were taken with the following conditions:

1. Antenna mounted on a ground plane 100x100mm.
2. Measurement Equipment: HP 8753ET 300KHZ~6 GHZ

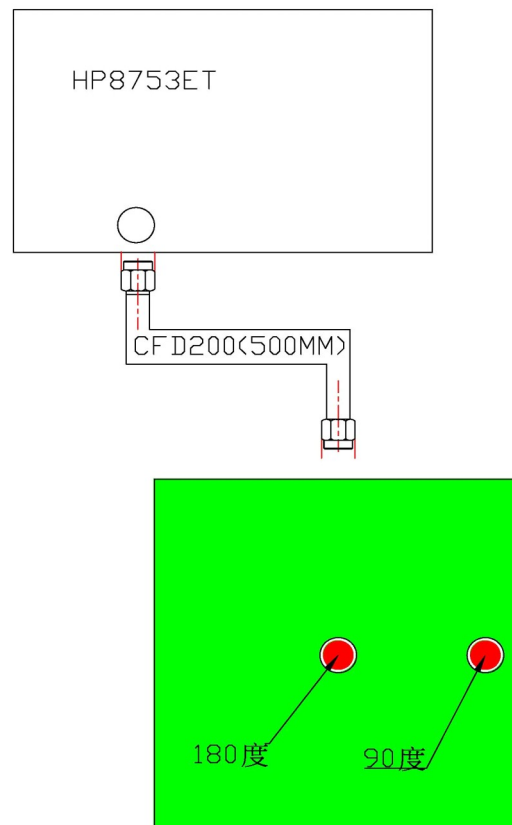

VSWR

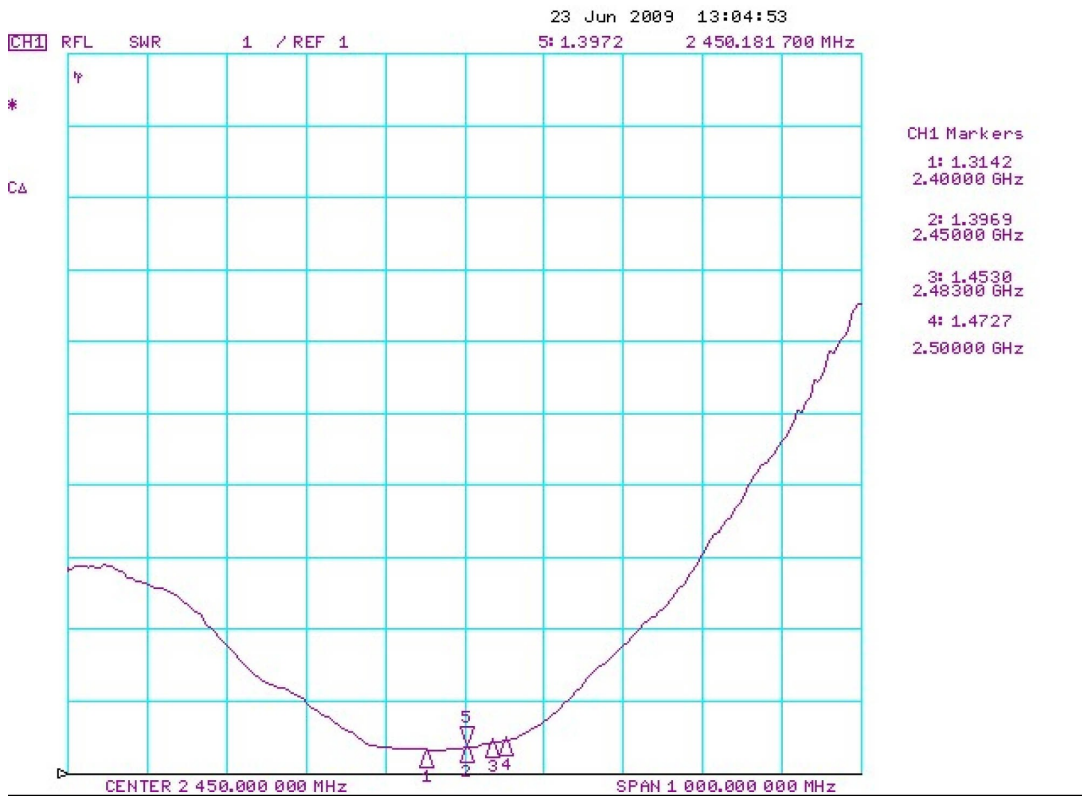

Return Loss

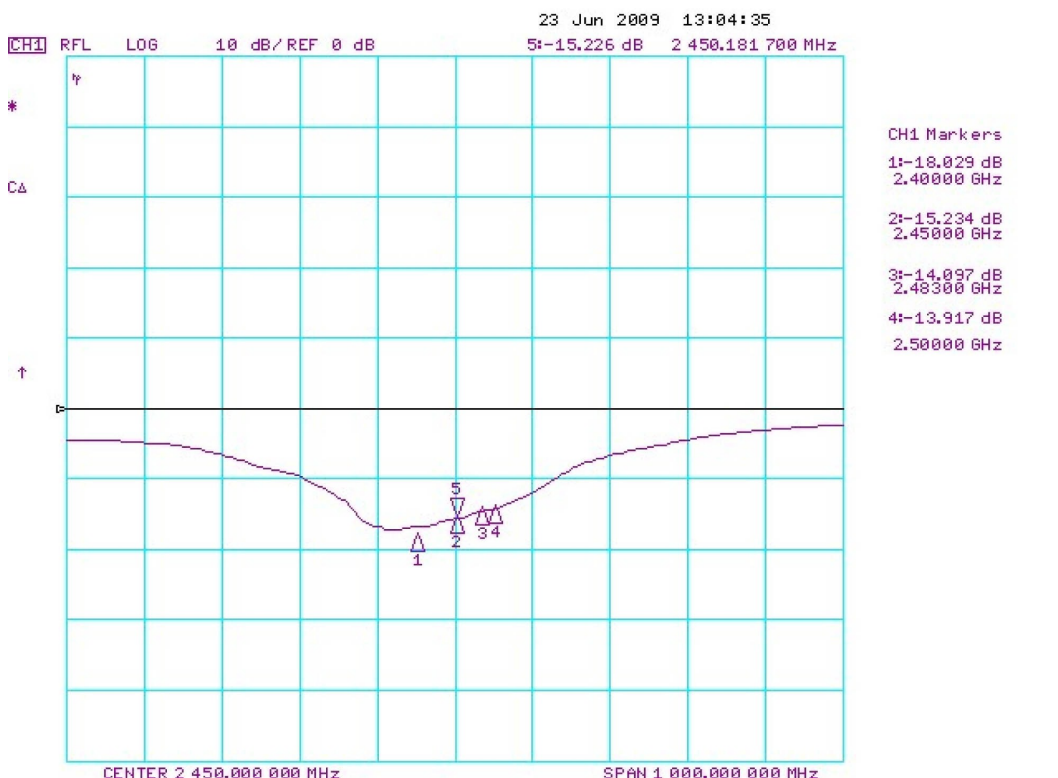

ANT-24G-S21-SMAR 'Right Angled' Mechanical Data

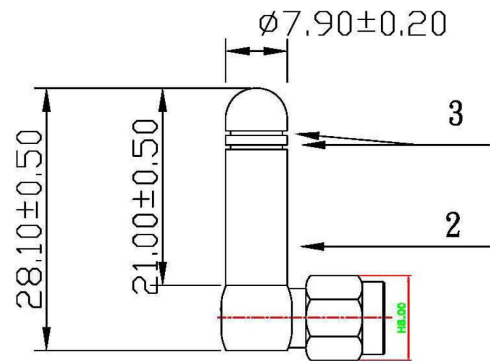

1. SMA Connector : Gold Plated Brass
2. Antenna Cover: Black TPU
3. Identification Stripes

Test Setup for Measurements

Characteristics for this antenna were taken with the following conditions:

1. Antenna mounted on a ground plane 100x100mm.
2. Measurement Equipment: HP 8753ET 300KHZ-6 GHZ



VSWR

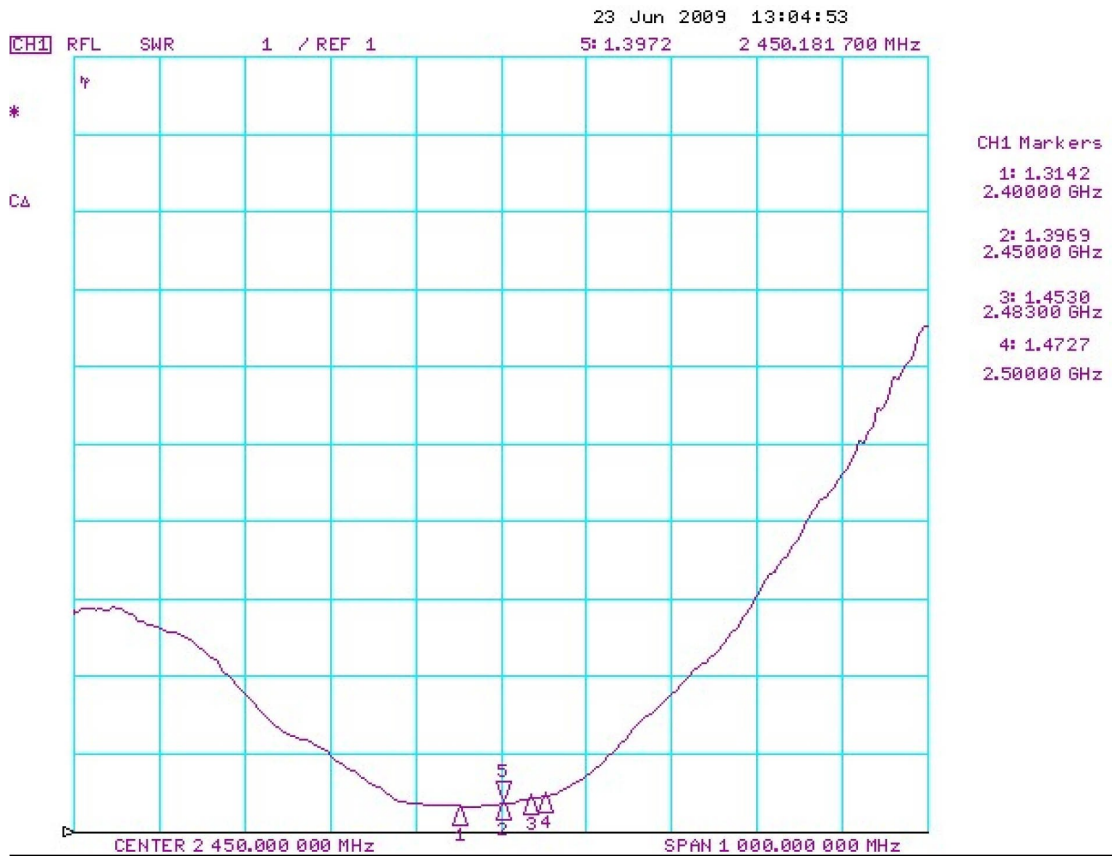

Return Loss

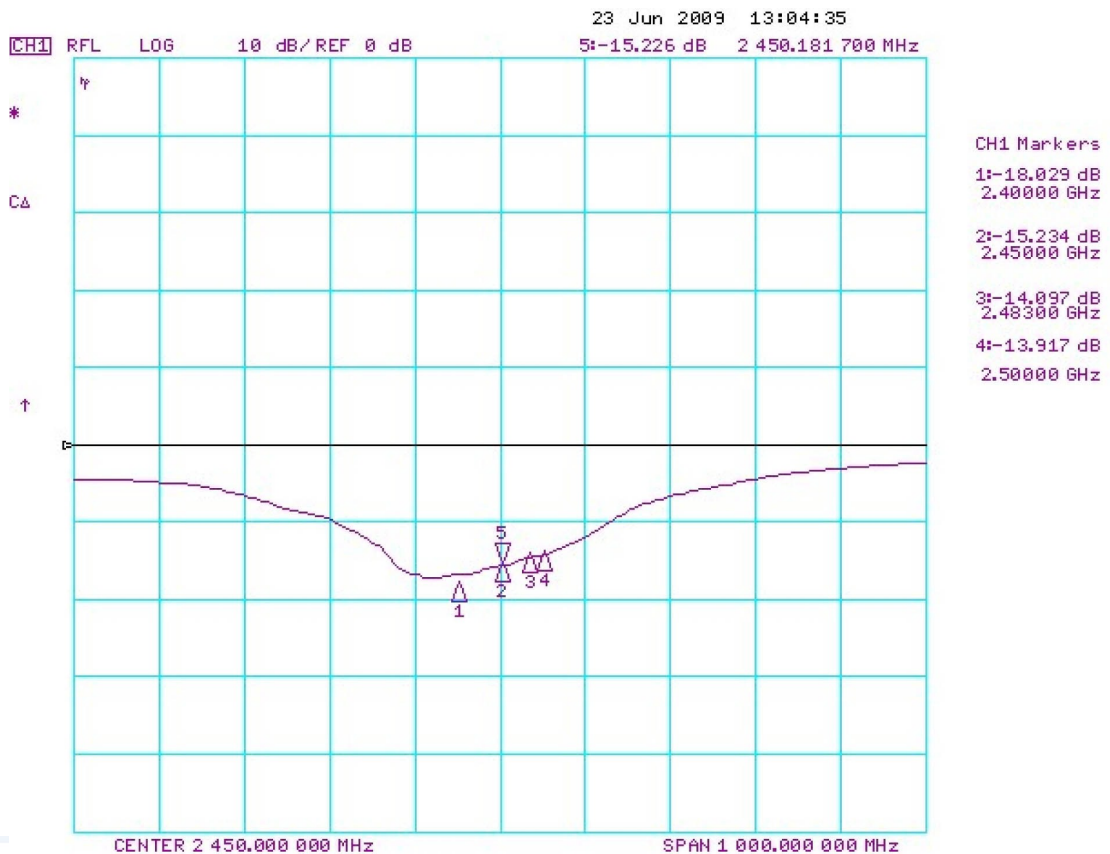

Antenna Pattern

Antenna pattern (XY plane)

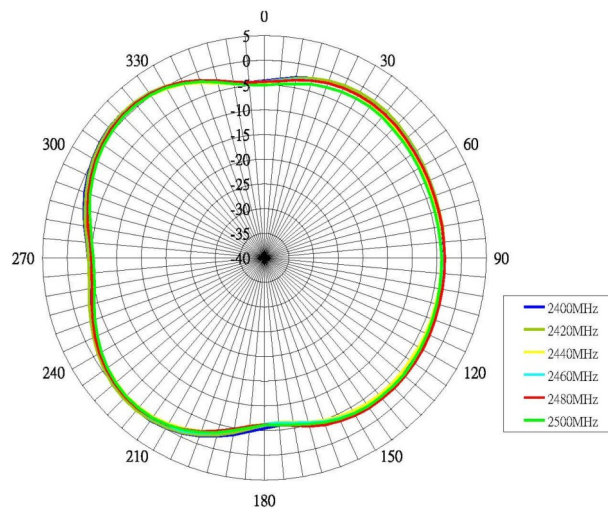

Antenna pattern (XZ plane)

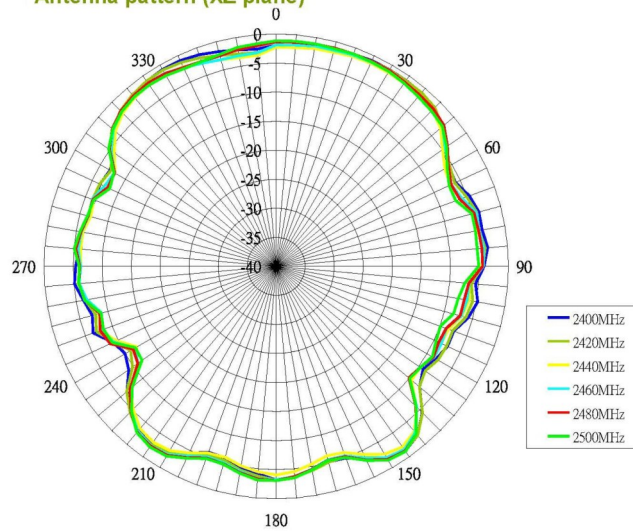

Antenna pattern (YZ plane)

