

ANT-DB1-VDP-xxx

Data Sheet

Product Description

The VDP Series is a compact, center-fed antenna that achieves efficient operation at any or all three frequency bands. Its durable, unobtrusive housing attaches permanently with integral adhesive to flat, non-conductive surfaces such as windows, drywall, ceiling tiles, plastic, etc. The antenna is supplied with 9.8 feet (3m) of RG-174 cable that enters from the bottom to facilitate vertical orientation. It can be terminated in a TNC, standard SMA, or FCC Part 15 compliant RP-SMA connector.

Features

- Tri-band (824–960MHz, 1.71–1.99GHz and 2.40–2.48GHz)
- Center-fed from the bottom
- Surface-mount
- Low VSWR
- Excellent performance
- Omni-directional pattern
- Fully weatherized, durable & unobtrusive
- TNC, SMA or RP-SMA connector

Electrical Specifications

Recom. Freq. Range:	Band 1: 824–960MHz Band 2: 1.71–1.99GHz Band 3: 2.40–2.48GHz
Wavelength:	½-wave
VSWR:	Band 1: ≤1.5 typ. at center Band 2: ≤1.9 typ. at center Band 3: ≤1.9 typ. at center
Peak Gain:	Band 1: –1.8dBi Band 2: –1.7dBi Band 3: –1.3dBi
Impedance:	50-ohms
Connector:	TNC, SMA or RP-SMA
Cable:	9.8' (3 m) RG-174 coax
Oper. Temp. Range:	–40°C to +80°C

Ordering Information

ANT-DB1-VDP-TNC (with TNC connector)
 ANT-DB1-VDP-SMA (with SMA connector)
 ANT-DB1-VDP-RPS (with RP-SMA connector)

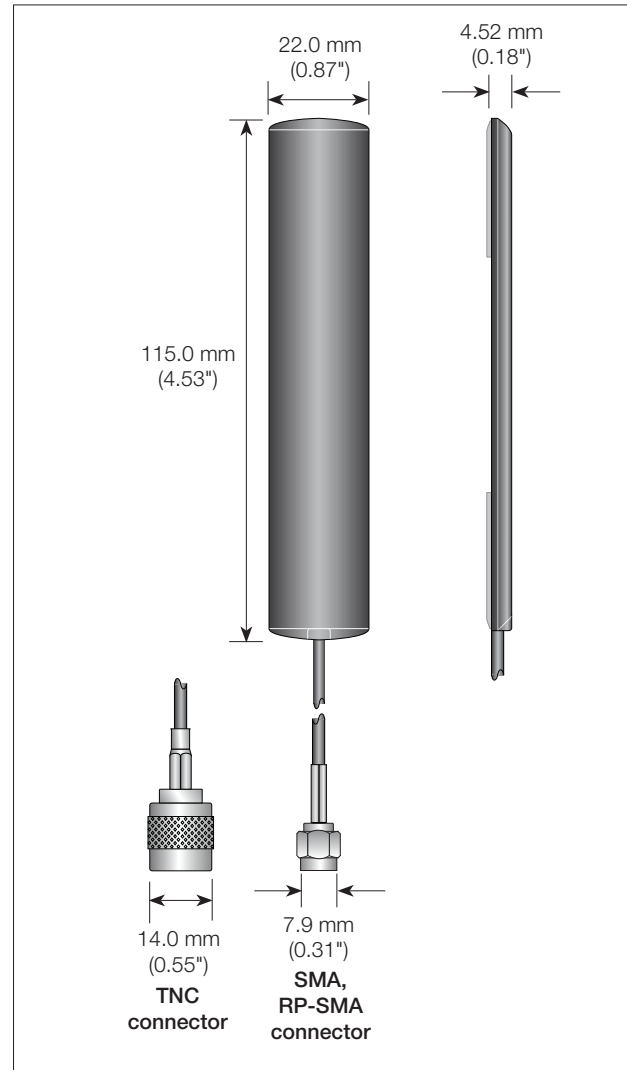

VSWR Graph

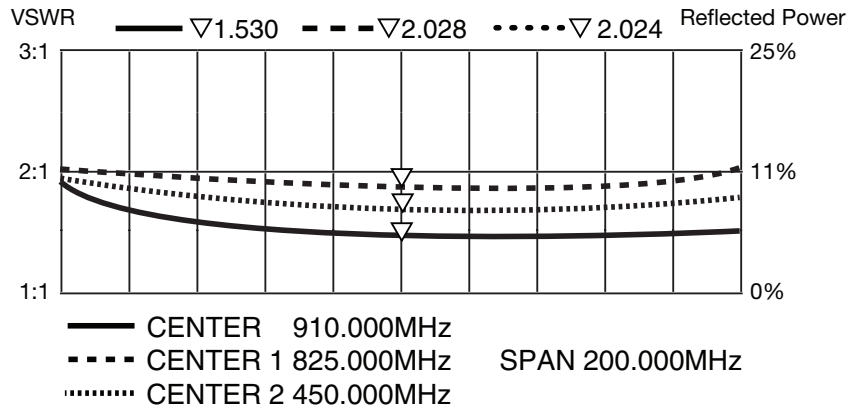

What is VSWR?

The Voltage Standing Wave Ratio (VSWR) is a measurement of how well an antenna is matched to a source impedance, typically 50-ohms. It is calculated by measuring the voltage wave that is headed toward the load versus the voltage wave that is reflected back from the load. A perfect match will have a VSWR of 1:1. The higher the first number, the worse the match, and the more inefficient the system. Since a perfect match cannot ever be obtained, some benchmark for performance needs to be set. In the case of antenna VSWR, this is usually 2:1. At this point, 88.9% of the energy sent to the antenna by the transmitter is radiated into free space and 11.1% is either reflected back into the source or lost as heat on the structure of the antenna. In the other direction, 88.9% of the energy recovered by the antenna is transferred into the receiver. As a side note, since the “:1” is always implied, many data sheets will remove it and just display the first number.

How to Read a VSWR Graph

VSWR is usually displayed graphically versus frequency. The lowest point on the graph is the antenna’s operational center frequency. In most cases, this will be different than the designed center frequency due to fabrication tolerances. The VSWR at that point denotes how close to 50-ohms the antenna gets. Linx specifies the recommended bandwidth as the range where the typical antenna VSWR is less than 2:1.