

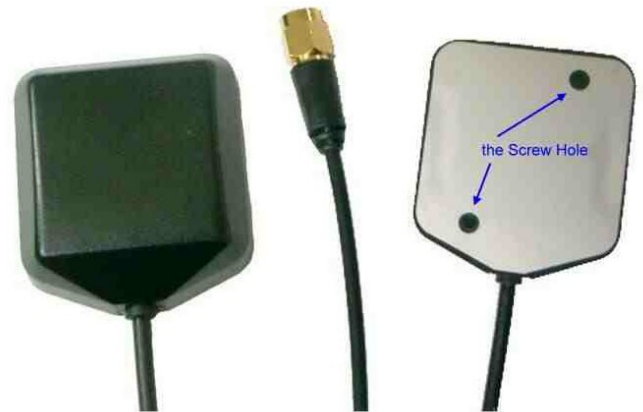

Mini GPS Antenna

Features

- Mini GPS Antenna with High Gain
- 1575.42MHz +/- 1MHz
- Active gain: +5dB
- VSWR < 1.5:1
- 5metres RG174 Cable
- SMA or MMCX Male Connector
- Dimensions 38 x 34 x 12 (Approx.)
- Mag Mount and Screw Fix



Applications

- Car GPS Systems
- Hand held GPS Systems

Description

A compact Antenna for GPS applications where high performance is required from a small size. The antenna includes a Low Noise Amplifier and incorporates both magnetic mount and screw fixings.

Ordering Information

Part Number	Description	Cable Length	Connector
ANT-GPSMG	Active GPS with cable and connector	5metres	SMA (M)
ANT-GPSMG-MMCX	Active GPS with cable and connector	5metres	MMCX (straight)

Mechanical Details

ANT-GPSMG

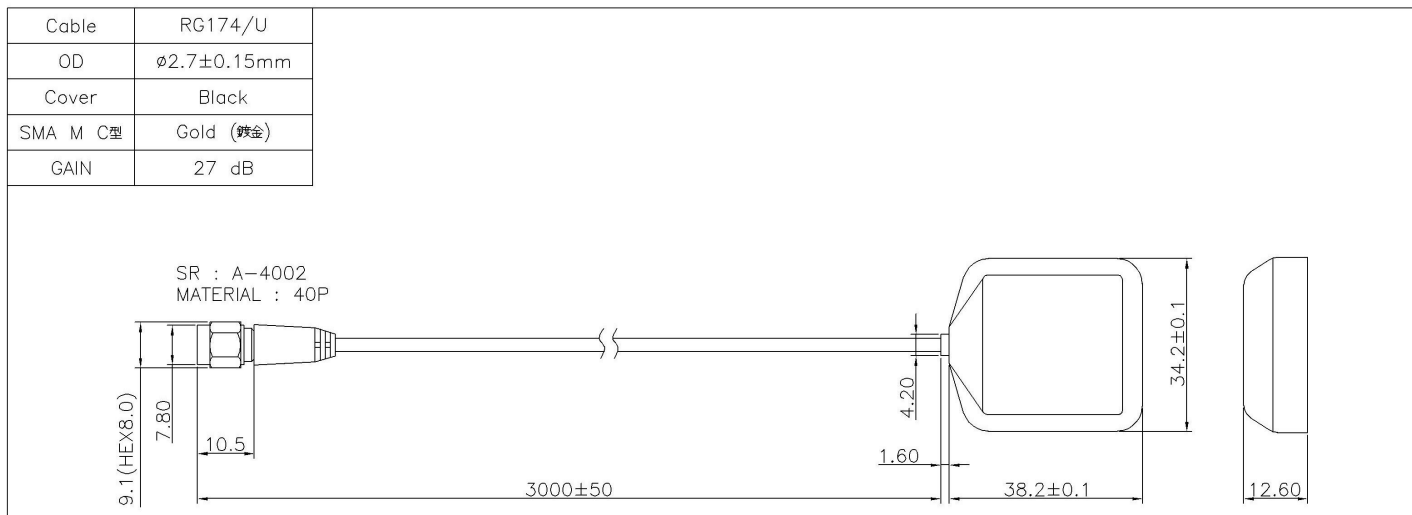

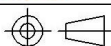
Material:		Treatment:		 TEKFUN CO., LTD. 得方國際有限公司			
Drawer	Design	Aprov	Tolerance	Unit: mm		TITLE	
			X=±0.5	Ver: A	Scale 1:1	Model NO	GPS-03A
			.X=±0.2	File NO: QR0402		Drawing NO	
			.XX=±0.1				
			.XXX=±0.05				

Mounting holes

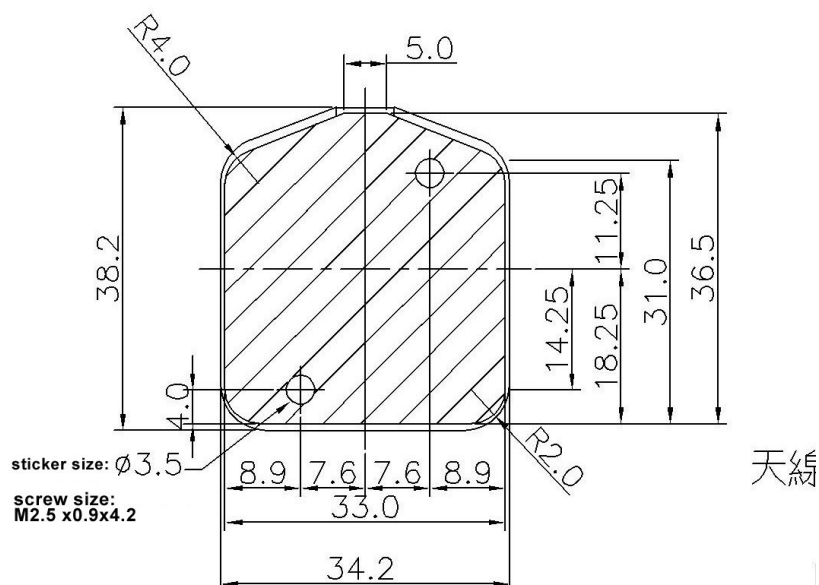

Mechanical Details

ANT-GPSMG-MMCX

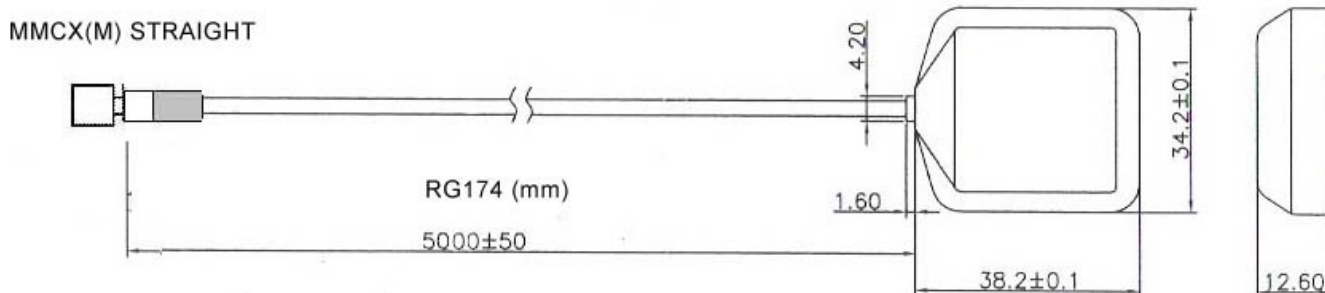

Test Data

GENERAL

3.1 ENVIRONMENTAL CONDITIONS

3.1.1 OPERATING TEMPERATURE	-40°C TO +85°C
3.1.2 STORAGE TEMPERATURE	-40°C TO +90°C (110°C MAX 1HR.)
3.1.3 RELATIVE HUMIDITY	20% TO 95%, rain

3.2 ELECTRICAL SPECIFICATIONS

3.2.1 INPUT VOLTAGE Require:	2.5 to 5.5 VDC
3.2.2 POWER CONSUMPTION	10~25 mA
3.2.3 OUTPUT CONNECTOR	SMA male
3.2.4 CABLE Shikoku Cable	RG174U Loss at 1575 MHz < 1.32 dB per meter

3.3 MECHANICAL SPECIFICATIONS

3.3.1 MOUNTING	Magnetic Mount
3.3.2 PULLING FORCE OF MAGNET	29.4N Min.
3.3.3 WATER PROOF	Waterproof (JISD0203 S2)
3.3.4 SHOCK	50G : Vertical Axis 30G : All Axis
3.3.5 VIBRATION	10 through 200Hz. Log sweep 3.0G (Sweep Time : 15 MIN.) 3 AXIS
3.3.6 MAGNET MOUNT	Withstand speed of upto 180Km/h.
3.3.7 CABLE PULLING FORCE	49N. Before Visible or electrical damage appears applying up to 49N pulling force between cable and antenna as well as between cable and connector.
3.3.8 BENDING TEST 1" radius	After bending test 90 degree right and left 1,000 cycles, no permanent damage found.
3.3.9 ANTI-COROSION	Based on JIS Z 2371, spray 5% saltwater at 35°C should not rust after 96Hrs,
3.3.10 Dimensions	See mechanical diagram.

4.0 ANTENNA

4.1 Outline Dimension	25x25x4 mm
4.2 FREQUENCY RANGE (minimum)	1,575.42 + 1.1 MHz
4.3 Frequency rejection (low side)	-10 dB or more rejection below 1500MHz
4.4 Frequency rejection (high side)	-10 dB or more rejection above 1650MHz
4.5 GAIN	1.0dBi minimum When mounted on a 25x25mm diameter metal ground plane
4.6 POLARIZATION	RHCP
4.7 AXIAL RATIO	3 dB MAX.
4.8 Bandwidth	10MHz

5.0 LNA

5.1 FREQUENCY RANGE (minimum)	1,575.42 + 1.1 MHz
5.2 GAIN	32dB +3 dB (+30°C) 32dB +4 dB (-40°C to +85°C)
5.3 NOISE FIGURE	1.8 dB MAX. (+30°C)
5.4 OUT OF BAND REJECTION	fo = 1,575.42 MHz fo + 20MHz 7dB MIN. fo + 30MHz 12dB MIN. fo + 50MHz 20dB MIN. fo + 100MHz 30dB MIN.
5.5 OUTPUT IMPEDANCE	50ohm
5.6 OUTPUT VSWR	2.0:1 MAX.

6.0 Other Specifications

6.1 ESD	ANTENNA SURFACE 15KV CONNECTOR PIN 8KV (TEST CONDITION JASOD001-94 C-3)
6.2 WEEE & Rohs compliant	Yes
7.0 MTBF	2,000 Hours
8.0 RECOMMENDED STORAGE CONDITION	-20°C~+45°C, HUMIDITY 80%MAX.
9.0 EXTERNAL APPEARANCE	NO VISIBLE STAIN OR FLAW.
10 Supplied DATA	GAIN and Current CONSUMPTION 5.0V +0.2VDC At 1575 MHz 30 degrees C.

● Experimental Results:



▲ Return Loss



▲ Test Gain Pattern Setup (Antenna with 70mm*70mm ground)

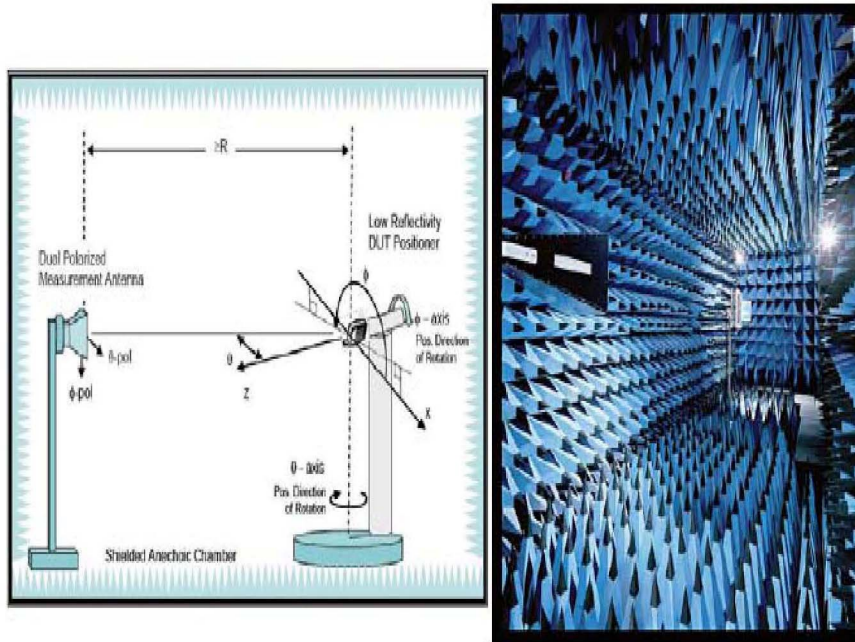

Antenna Pattern Measurement

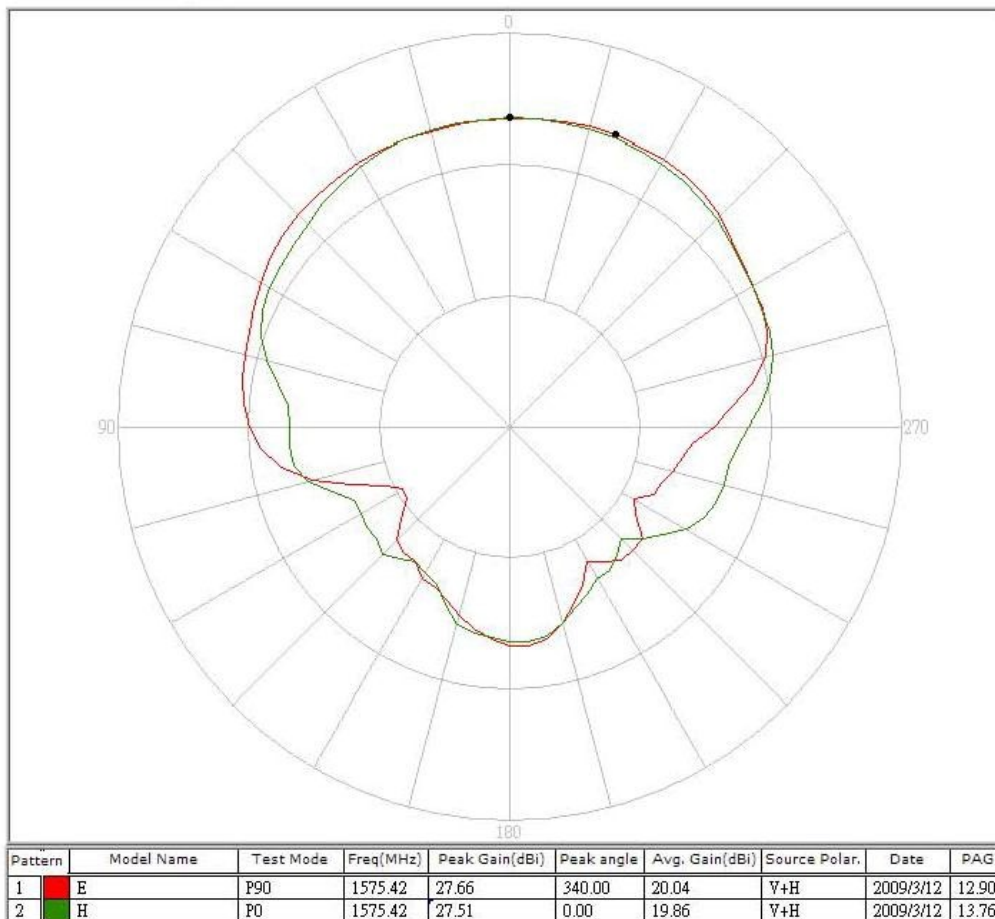

7M CABLE GPS ANTENNA 3D PATTERN(at 3.0V)

XY

Model name

GPS ANTENNA

Test frequency / Polarization

1575.42 MHz / Vector XY

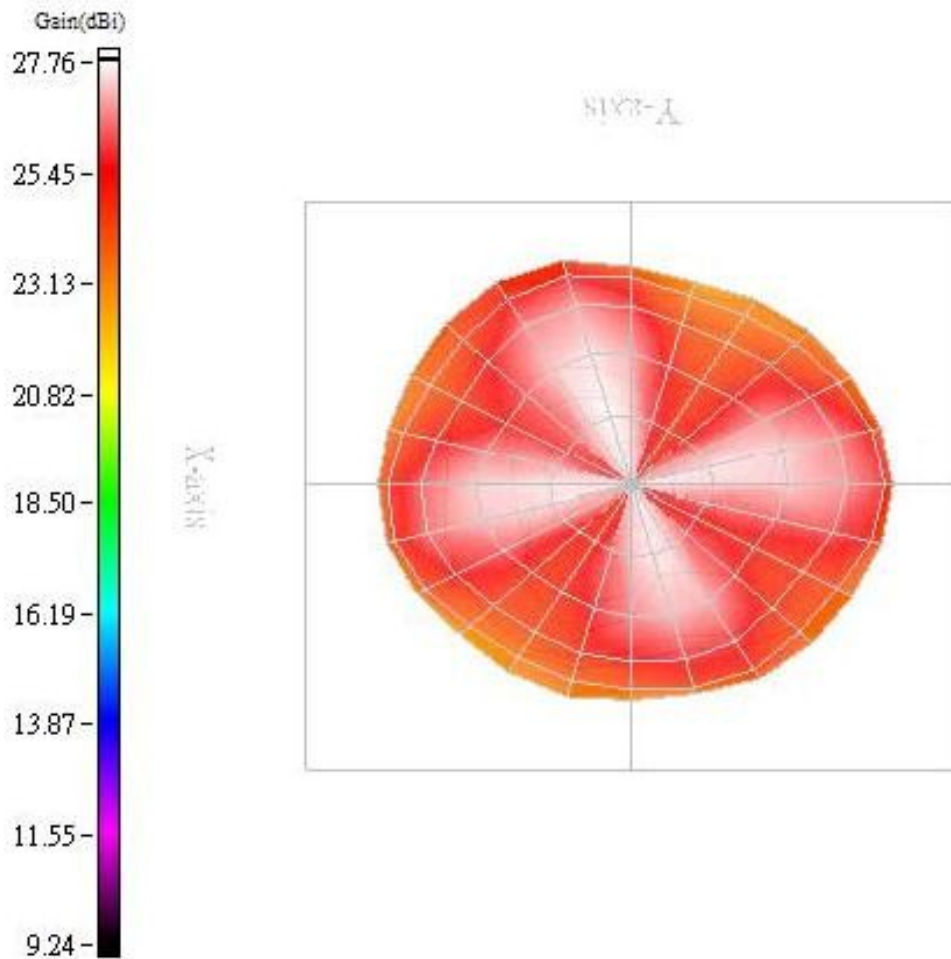

Max gain= 27.76dBi, at (0, 195)
Average Power= 19.78dBm
Directivity(dB)= 4.48
Efficiency= 19.28dB, 8462.62%

YZ

Model name

GPS ANTENNA

Test frequency / Polarization

1575.42 MHz / Vector YZ

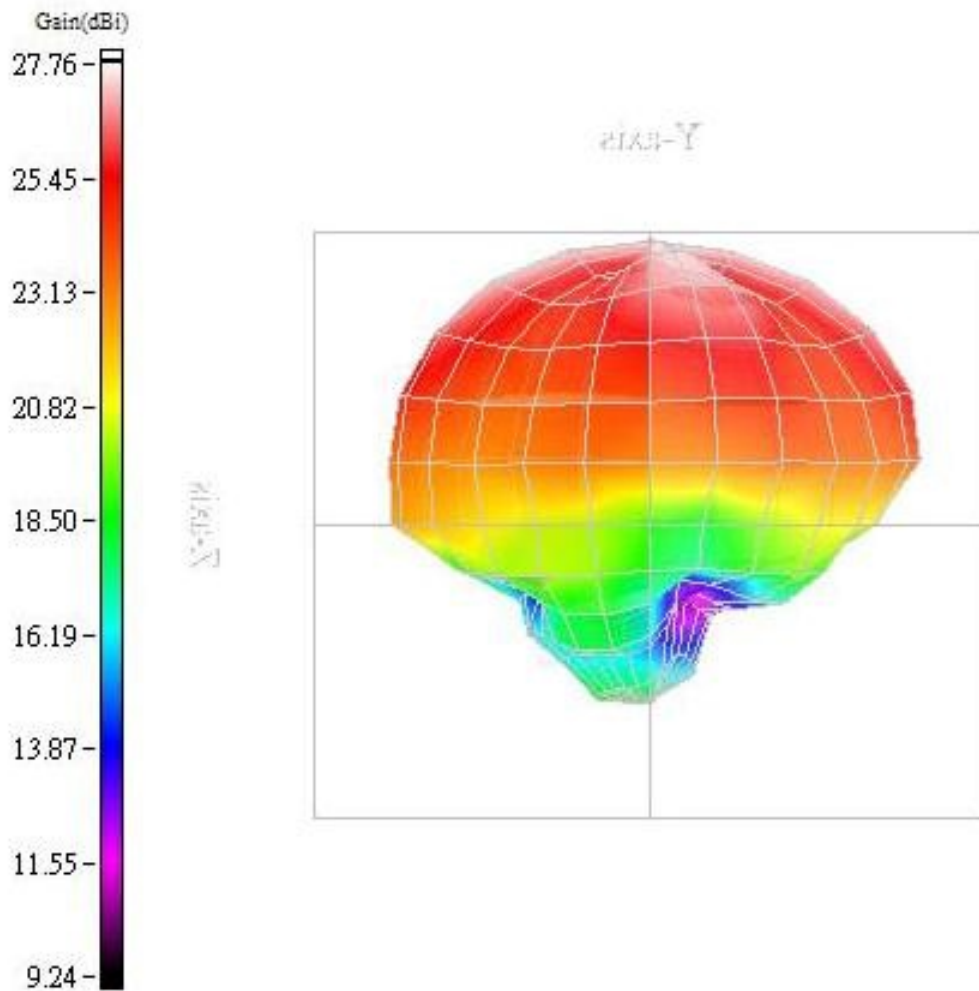

Max gain= 27.76dBi, at (0, 195)
Average Power= 19.78dBm
Directivity(dB)= 4.48
Efficiency= 19.28dB, 8462.62%

XZ

Model name

GPS ANTENNA

Test frequency / Polarization

1575.42 MHz / Vector XZ

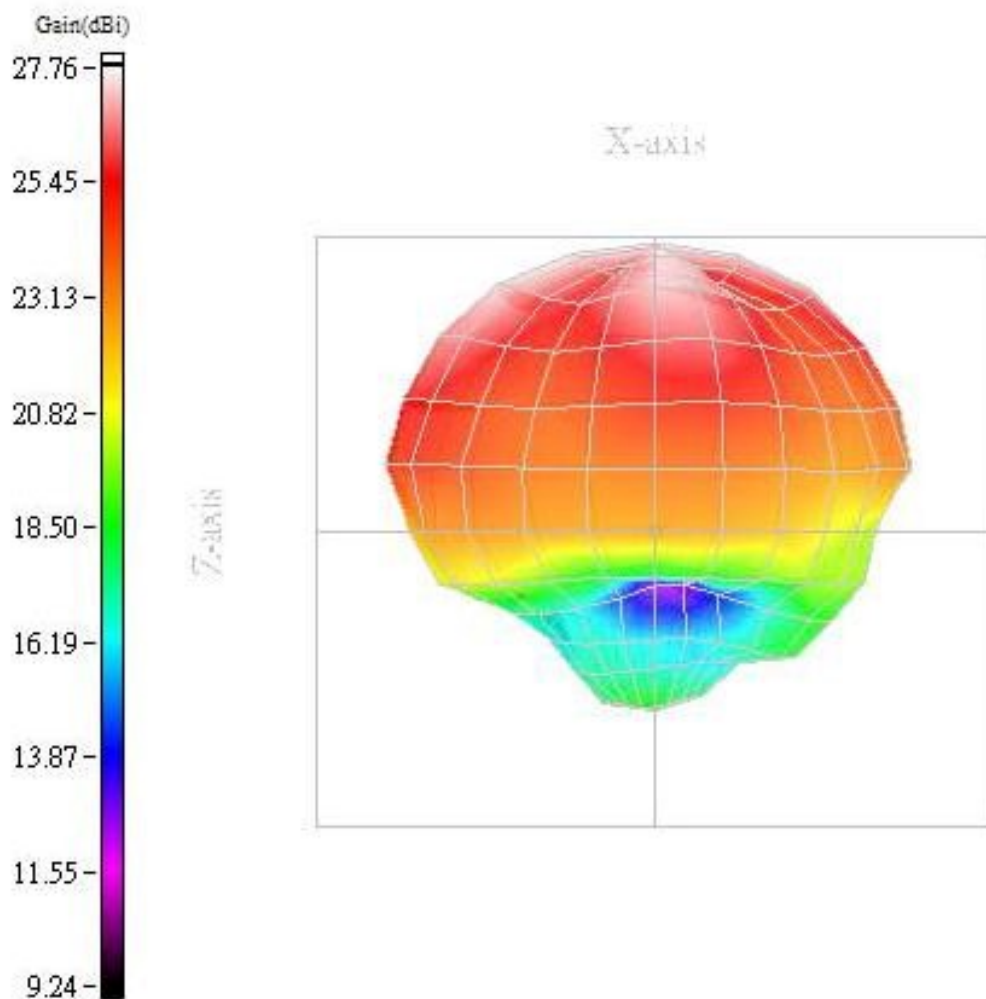

Max gain= 27.76dBi, at (0, 195)
Average Power= 19.78dBm
Directivity(dB)= 4.48
Efficiency= 19.28dB, 8462.62%