

B AP-107SP-CP

ITEM #	PART #	QTY	DESCRIPTION
1	AP-107SP-8	1	PLUG ASSEMBLY
2	AJ-107S-2	1	STRAIN RELIEF
3	AP-107SP-6	1	SHELL
4	SEE TABLE #1	1	BUSHING
5	SEE TABLE #1	1	WASHER, STAINLESS STEEL
6	SEE TABLE #1	1	SPRING, STAINLESS STEEL
7	AP-116-6	1	STUD, ALUM ANODIZED

TABLE #1				
PART #	Ø CABLE	BUSHING	WASHER	SPRING
AP-107SP-01	Ø .165 ± .010	AP-116-17	AP-116-2	AP-116-4
AP-107SP-02	Ø .228 ± .010	AP-116-18	AP-116-2	AP-116-4
AP-107SP	Ø .250 ± .010	AP-116-8	AP-116-2	AP-116-4
AP-107SP-04	Ø .290 ± .010	AP-116-19	AP-116-2	AP-116-4
AP-107SP-05	Ø .320 ± .010	AP-116-20	AP-116-22	AP-116-21

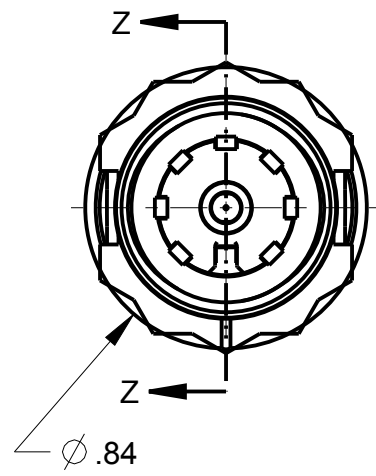
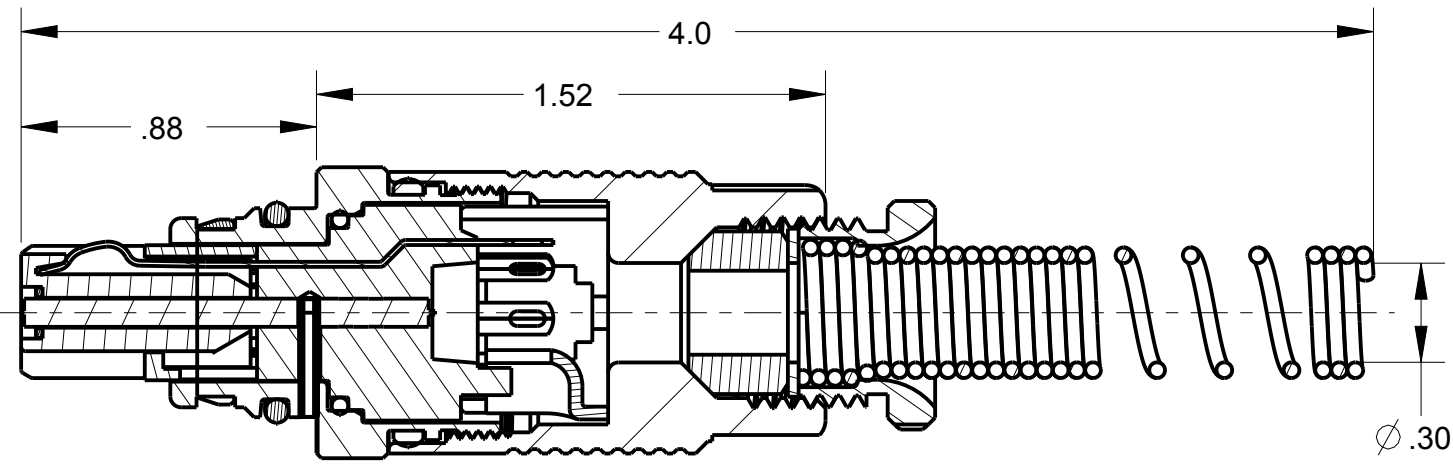
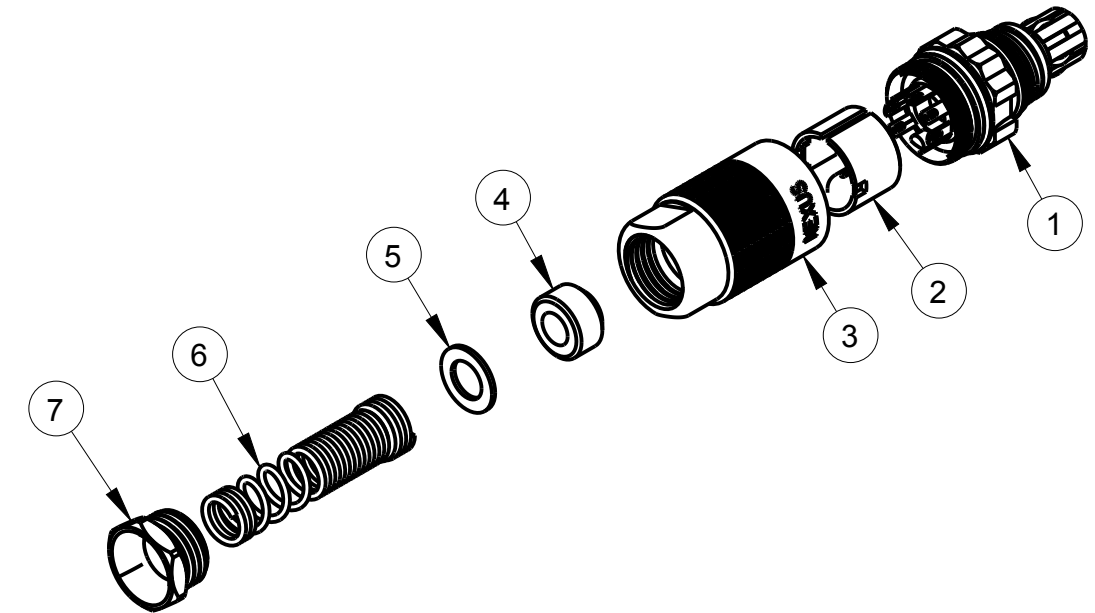

SECTION Z-Z

THIS DOCUMENT CONTAINS PROPRIETARY INFORMATION OF NEXUS, INCORPORATED AND SUCH INFORMATION MAY NOT BE DISCLOSED TO OTHERS FOR ANY PURPOSE OR USED FOR ANY PURPOSE WITHOUT THE WRITTEN CONSENT OF NEXUS.

LET.	REVISION	CN #	DATE	CHK.
B	ADD: AP-107SP-01 TO AP-107SP-05, DEL: .25	229	9/14 2015	HR
A	NEW RELEASE		6/26 2015	HR

DWN.BY	HR	DATE	6/26/15
CHECKED BY		DATE	
APPR.BY		DATE	

UNLESS OTHERWISE SPECIFIED:
DIMENSIONS ARE IN INCHES &/OR (mm)
TOLERANCES:
DECIMAL: .XX[X.X] .XXX[X.XX]
± .0X[0.X] ± .00X[0.0X]
FRACTION: X/X X/XX
ANGLES: X X°

MATERIAL	
FINISH	
WEIGHT —	SCALE = 1.00 :1
TITLE 7 CONDUCTOR AUDIO PLUG WITH SPRING BEND RELIEF	
DO NOT SCALE DWG.	SHEET 1 OF 1

NEXUS
STAMFORD, CONN

SIZE **B** DWG. NO. AP-107SP-CP