

# 1. SPECIFICATION

AP-1205G-P3

ITEM		UNITS	SPECIFICATIONS	CONDITIONS
01	Rated Voltage	V	5	 <p>Standard state, standard drive circuit. Square wave 1/2 duty.</p>
02	Operating Voltage	V	4 ~ 8	
03	Consumption Current	mA Max.	<p>Mean: 50</p> <p>Peak: 150</p>	
04	Sound pressure level (Distance at 10cm )	dB(A) Min.	85	Rated voltage, rated frequency.
05	Direct Current Resistance	$\Omega$	42±5	
06	Rated Frequency	Hz	2400	

REV NO.	REVISION NOTE	APPROVAL	DATE
---------	---------------	----------	------

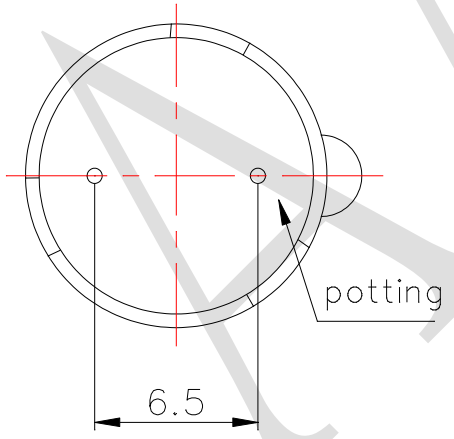
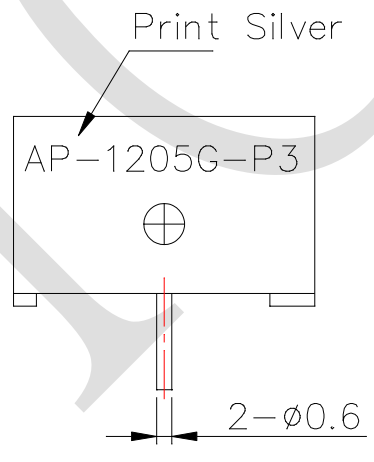
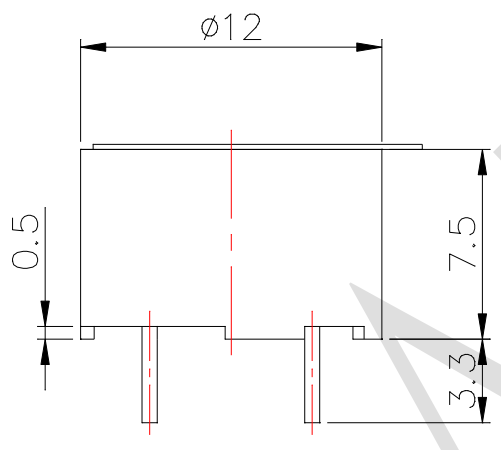
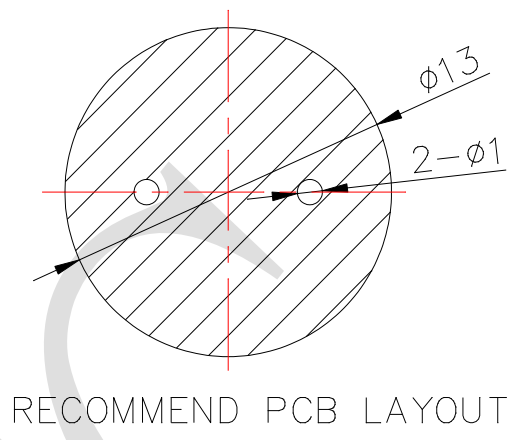
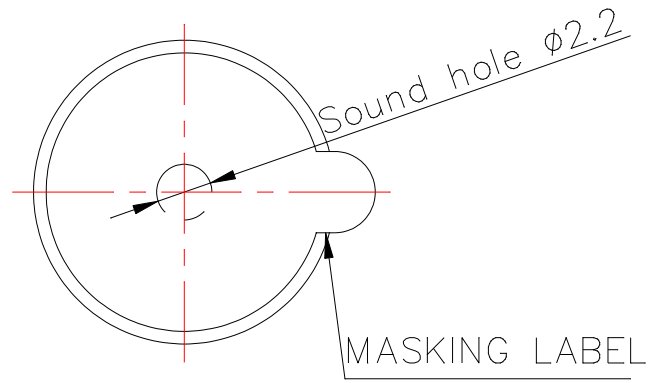

RoHS

TITLE: ELECTRO MAGNETIC BUZZER		DRAWN: Sunny 2015-9-29	SCALE: 4:1	SHEET: 1 of 1
PART NO. AP-1205G-P3		DESIGNED: R&D OF AAT	UNITS: mm	
DWG NO. FDC-120075F-05024R42-1		CHECKED:	TOLERANCE $\pm 0.5$	
		APPROVAL:	UNLESS OTHERWISE SPECIFIED:	
REV 2		MATERIAL: PBT	ONE PLACE DECIMAL $\pm$ ***	
			TWO PLACE DECIMAL $\pm$ ***	
			THREE PLACE DECIMAL $\pm$ ***	



ADVANCED ACOUSTIC TECHNOLOGY CORPORATION