

ITEM #	PART #	QTY	DESCRIPTION	MATERIAL
1	AP-136-1	1	SHELL ASS'Y	GLASS FILLED NYLON & 303 SS
2	AP-126-6	1	INSERT ASS'Y	DIALYPHTHALATE, TYPE SDGF & GOLD PLATED BRASS
3	AP-105-5	1	STRAIN RELIEF	NYLON
4	AP-116-3	1	WASHER	RUBBER
5	AP-136-8	1	NUT ADAPTER	ALUMINUM, BLACK CHROME
6	AP-136-6	1	CLAMP SHIELD, OUTER	NICKEL PLATED BRASS
7	AP-136-5	1	CLAMP SHIELD INNER	NICKEL PLATED BRASS
8	SEE TABLE #1	1	BUSHING	RUBBER
9	SEE TABLE #1	1	WASHER	STAINLESS STEEL
10	SEE TABLE #1	1	SPRING	302 STAINLESS STEEL
11	AP-116-6	1	STUD	ANODIZED ALUMINUM ALLOY

C AP-136

PART #	Ø CABLE	TABLE #1		
		BUSHING	WASHER	SPRING
AP-136/1	Ø .165 ± .010	AP-116-17	AP-116-2	AP-116-4
AP-136/2	Ø .228 ± .010	AP-116-18	AP-116-2	AP-116-4
AP-136	Ø .250 ± .010	AP-116-8	AP-116-2	AP-116-4
AP-136/4	Ø .290 ± .010	AP-116-19	AP-116-2	AP-116-4
AP-136/5	Ø .320 ± .010	AP-116-20	AP-116-22	AP-116-21

NOTES:
1) UNLESS OTHERWISE SPECIFIED, CONNECTOR MEETS ALL GENERAL REQUIREMENTS & SPECIFICATIONS OF MIL-C-55116

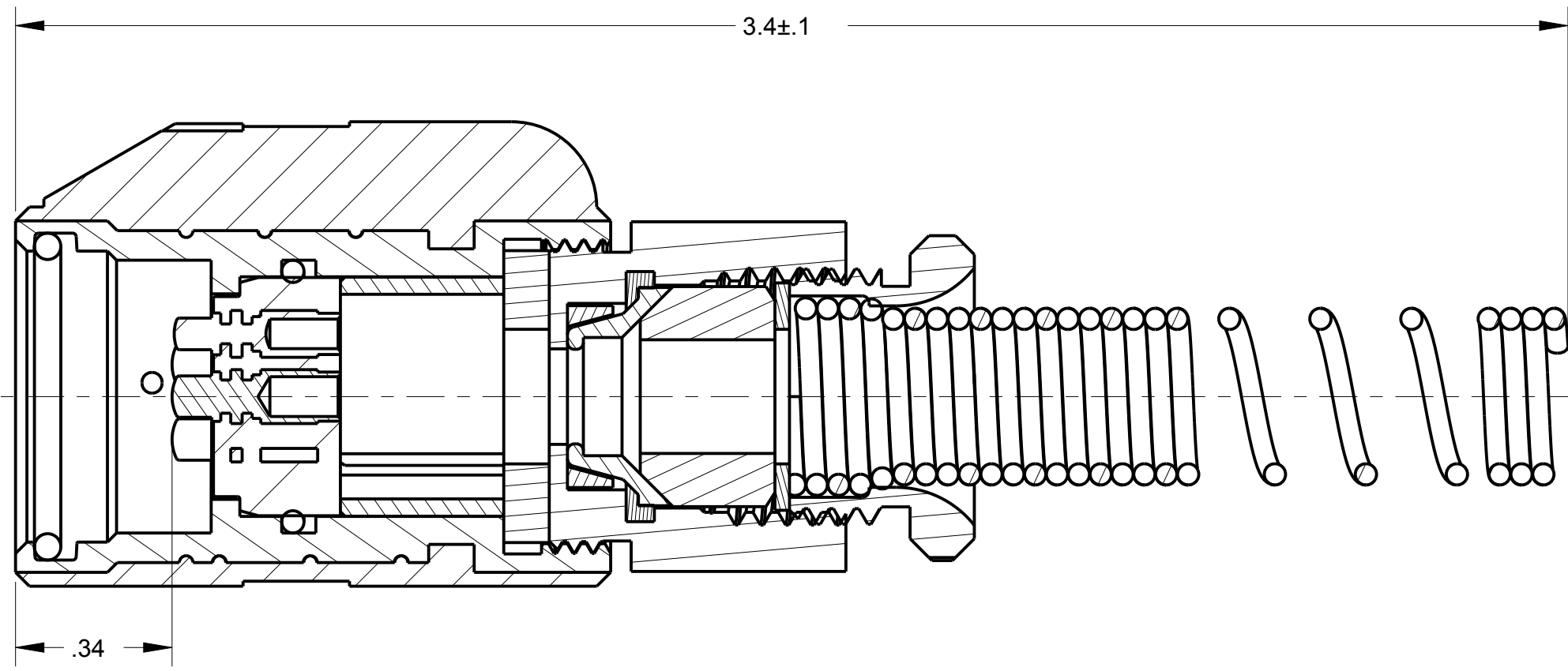
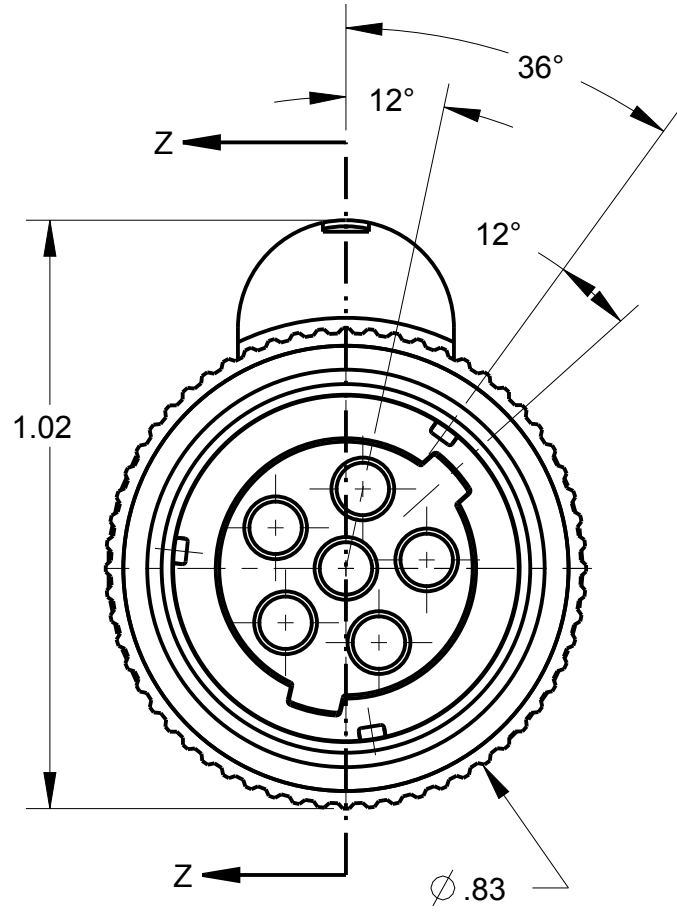
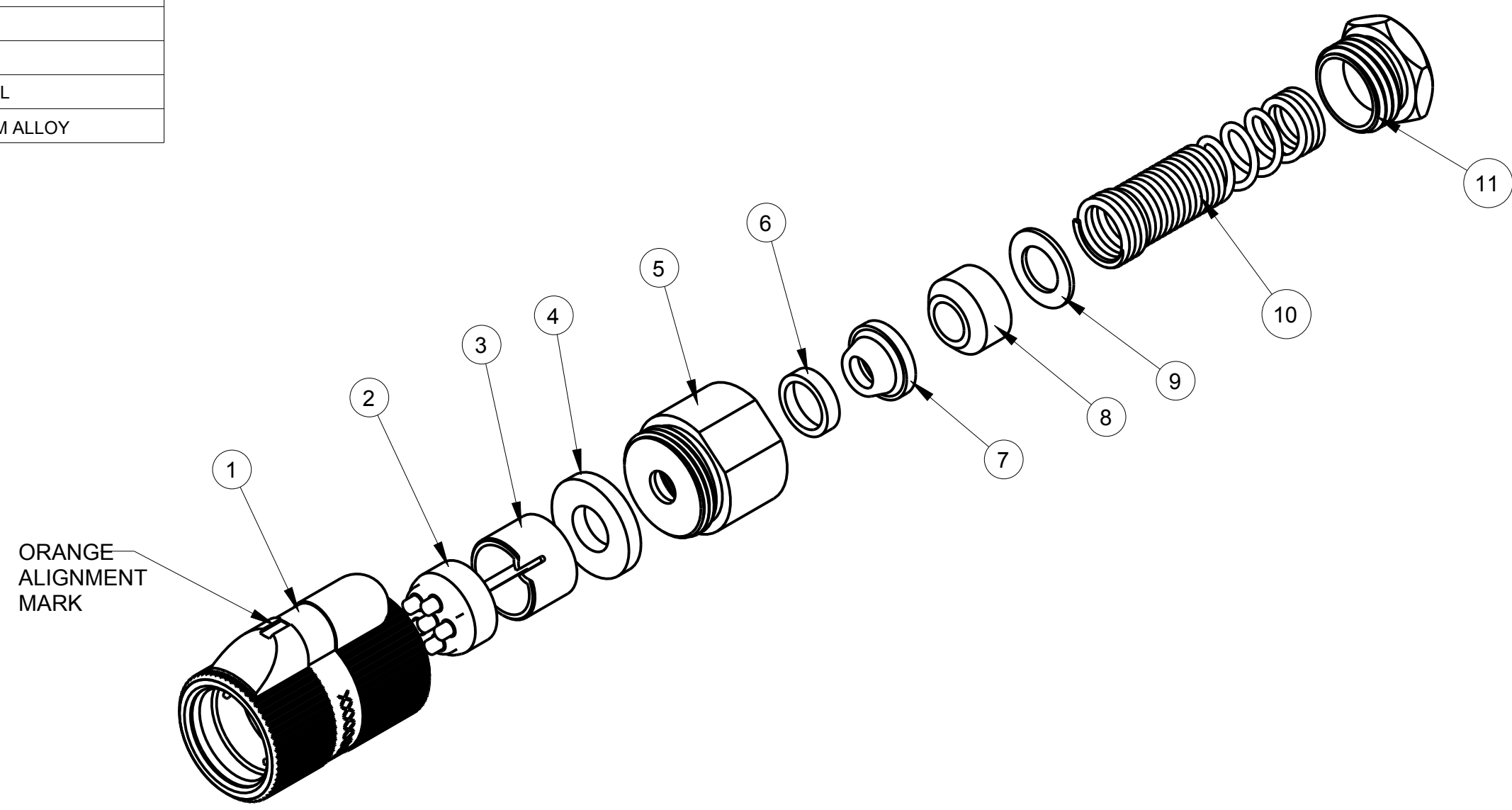

SECTION Z-Z

THIS DOCUMENT CONTAINS PROPRIETARY INFORMATION OF NEXUS, INCORPORATED AND SUCH INFORMATION MAY NOT BE DISCLOSED TO OTHERS FOR ANY PURPOSE OR USED FOR ANY PURPOSE WITHOUT THE WRITTEN CONSENT OF NEXUS.

F	ADD PINS TO P/L	101	2/25 2011	HR	DWN.BY	MNF	DATE	5/31/96	MATERIAL
E	2) REMOVE NUT ADAPTER(REF) AP-136-4 1) REMOVE GASKET (REF) AP-136-7	079	7/30 2010	GPH	CHECKED BY	L SMITH	DATE	9/9/97	FINISH
D	REVISED & DRAWN ON CAD	0259	2/24 1997	LS	APPR.BY	L SMITH	DATE	9/9/97	WEIGHT
C	REVISE DRAWING TO MATCH PART	0121	4/15 1994	WHF	UNLESS OTHERWISE SPECIFIED DIMENSIONS ARE IN INCHES & OR (mm)				SCALE = 1.00 :1
B	ADDED CALLOUTS	0002	5/30 1991	JRJ	TOLERANCES: DECIMAL: ±.XX[X.X] ±.XXX[X.XX] ±.XXXX[X.XXX] ±.01[0.3] ±.003[0.08] ±.0005[0.13]				TITLE
A	2) CONFIGURATION CHANGED 1) 12° WAS 18°		5/4 1988		FRACTION: ±X/XX ± 1/64 ANGLS: ± X ° ± 5 °				NEXUS STAMFORD, CONN. SIZE DWG. NO. C AP-136
LET	REVISION	CN #	DATE	CHK	DO NOT SCALE DWG. SHEET 1 OF 1				