

ITEM #	PART #	QTY	DESCRIPTION	MATERIAL
1	AP-145-1M	1	SHELL ASS'Y	303 SS & NEOPRENE
2	AP-145-6	1	INSERT ASS'Y	DIALLYPHTHALATE, TYPE SDGF & GOLD PLATED BRASS
3	AP-105-5	1	STRAIN RELIEF	NYLON
4	AP-116-3	1	WASHER	RUBBER
5	AP-116-7	1	NUT ADAPTER	ALUMINUM ALLOY ANODIZED
6	SEE TABLE #1	1	BUSHING	RUBBER
7	SEE TABLE #1	1	WASHER	STAINLESS STEEL
8	SEE TABLE #1	1	SPRING	302 STAINLESS STEEL
9	AP-116-6	1	STUD	ANODIZED, ALUMINUM ALLOY

C AP-145M-CP

TABLE #1				
PART #	CABLE SIZE	BUSHING	WASHER	SPRING
AP-145M-1	∅ .165 ± .010	AP-116-17	AP-116-2	AP-116-4
AP-145M-2	∅ .228 ± .010	AP-116-18	AP-116-2	AP-116-4
AP-145M	∅ .250 ± .010	AP-116-8	AP-116-2	AP-116-4
AP-145M-4	∅ .290 ± .010	AP-116-19	AP-116-2	AP-116-4
AP-145M-5	∅ .320 ± .010	AP-116-20	AP-116-22	AP-116-21

NOTES:
 1) UNLESS OTHERWISE SPECIFIED, THIS CONNECTOR MEETS ALL GENERAL REQUIREMENTS & SPECIFICATIONS OF MIL-C-55116
 2) MATES WITH U-183/U PANEL MOUNT CONNECTOR & U-228/U INLINE CONNECTOR

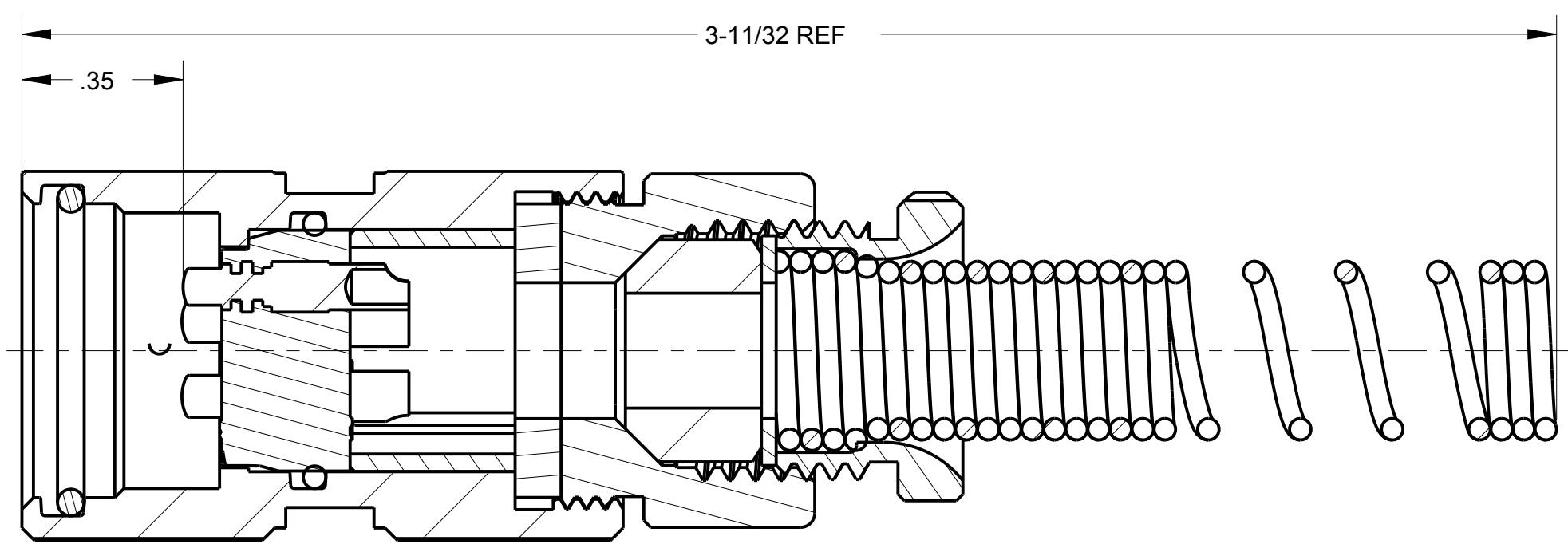
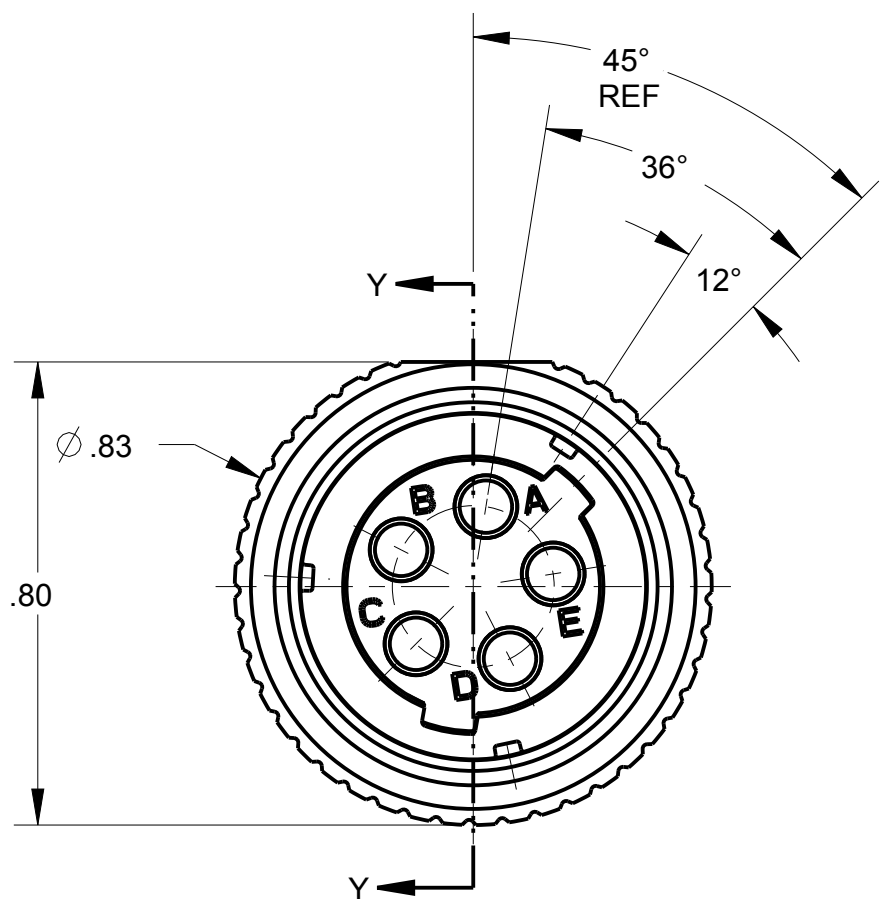
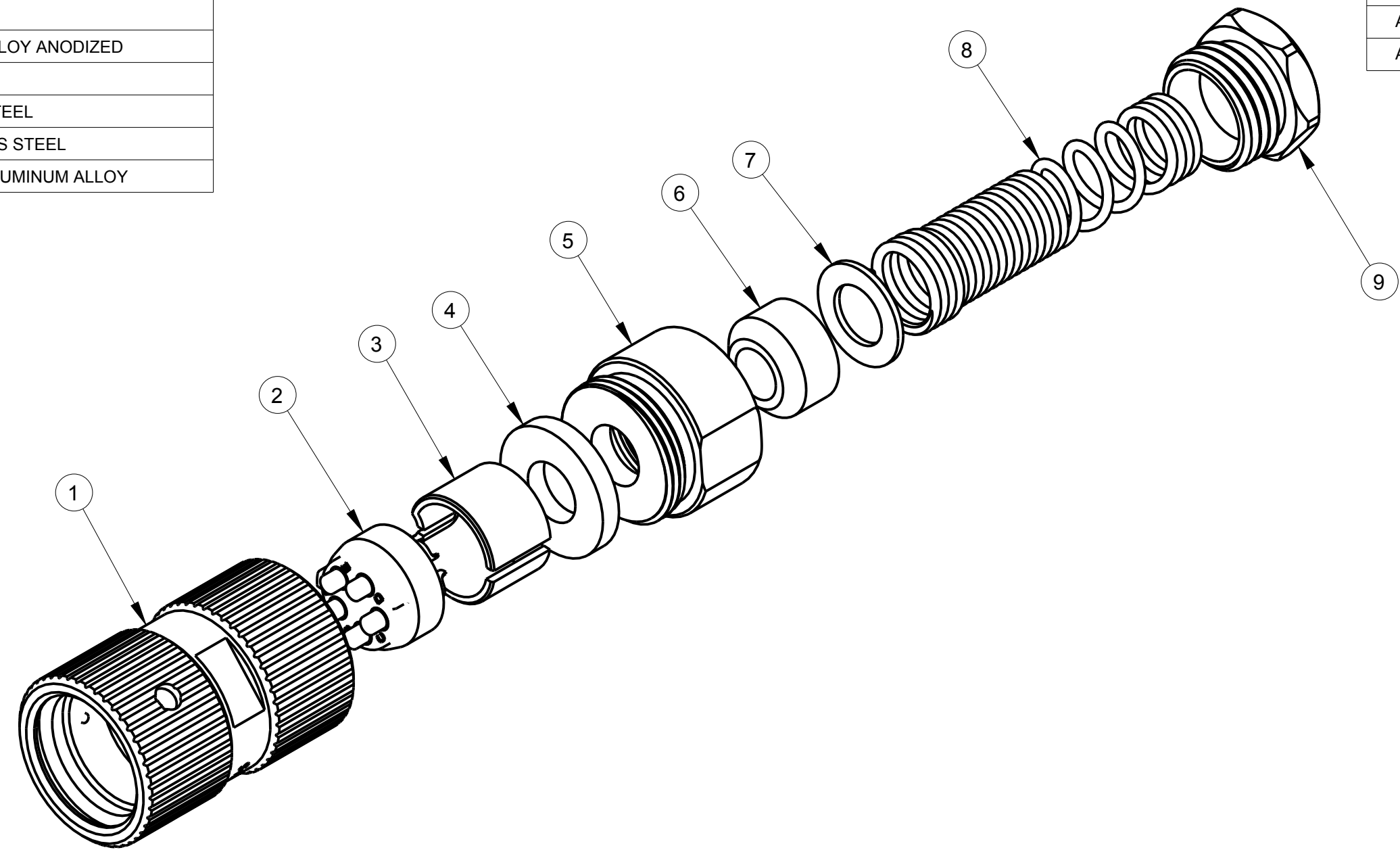

SECTION Y-Y
SCALE 3.000

THIS DOCUMENT CONTAINS PROPRIETARY INFORMATION OF NEXUS, INCORPORATED AND SUCH INFORMATION MAY NOT BE DISCLOSED TO OTHERS FOR ANY PURPOSE OR USED FOR ANY PURPOSE WITHOUT THE WRITTEN CONSENT OF NEXUS.

E	DEL: 36° , ADD: 45° REF: 36° ; BOM	226	8/24 2015	HR	DWN.BY GPH	DATE 9/14/09
D	ADD P/N's TO P/L	101	2/25 2011	HR	CHECKED BY GPH	DATE 9/14/09
C	ADDED WASHER & SPRING TO TABLE, ADDED "REF" TO O-RING, ADDED SEE TABLE 1 TO WASHER & SPRING CALLOUT, CHANGE MARKING TO NEXUS	052	3/26 2010	GPH	APPR.BY GPH	DATE 9/14/09
B	REMOVE "U-220/U" FROM NOTE 2	034	12/14 2009	GPH	UNLESS OTHERWISE SPECIFIED DIMENSIONS ARE IN INCHES & OR (mm)	
A	INITIAL RELEASE	028	9/14 2009	GPH	TOLERANCES: DECIMAL: ±.XX(X.X) ±.XXX(X.XX) ±.000(X.XXX) ±.0X(0.X) ±.00X(0.0X) ±.000X(0.0XX) FRACTION: ±X/XX ±.XXX ANGLES: ±X° ±'X"	

MATERIAL		FINISH		NEXUS STAMFORD, CONN
WEIGHT		SCALE = 1.00 :1		
TITLE				C
AUDIO PLUG				
DO NOT SCALE DWG.		SHEET 1 OF 1		DWG. NO. AP-145M-CP

LET	REVISION	CN #	DATE	CHK