

ITEM #	PART #	QTY	DESCRIPTION	MATERIAL
1	SEE TABLE #1	1	SHELL ASS'Y	GLASS FILLED NYLON & 303 SS
2	AP-145-6	1	INSERT ASS'Y	DIALLYPHTHALATE, TYPE SDGF & GOLD PLATED BRASS
3	AP-105-5	1	STRAIN RELIEF	NYLON
4	AP-116-3	1	WASHER	RUBBER
5	AP-116-7	1	NUT ADAPTER	ALUMINUM, ANODIZED
6	SEE TABLE #1	1	BUSHING	RUBBER
7	AP-116-2	1	WASHER	STAINLESS STEEL
8	AP-116-4	1	SPRING	302 STAINLESS STEEL
9	AP-116-6	1	STUD	ALUMINUM ALLOY, ANODIZED

C AP-145

TABLE #1			
AUDIO PLUG #	MILITARY PART #	SHELL ASS'Y	BUSHING
AP-145/1	M55116/3-1	AP-145-1	AP-116-17
AP-145/2	M55116/3-2	AP-145-2	AP-116-18
AP-145/3	M55116/3-3	AP-145-3	AP-116-8
AP-145/4	M55116/3-4	AP-145-4	AP-116-19

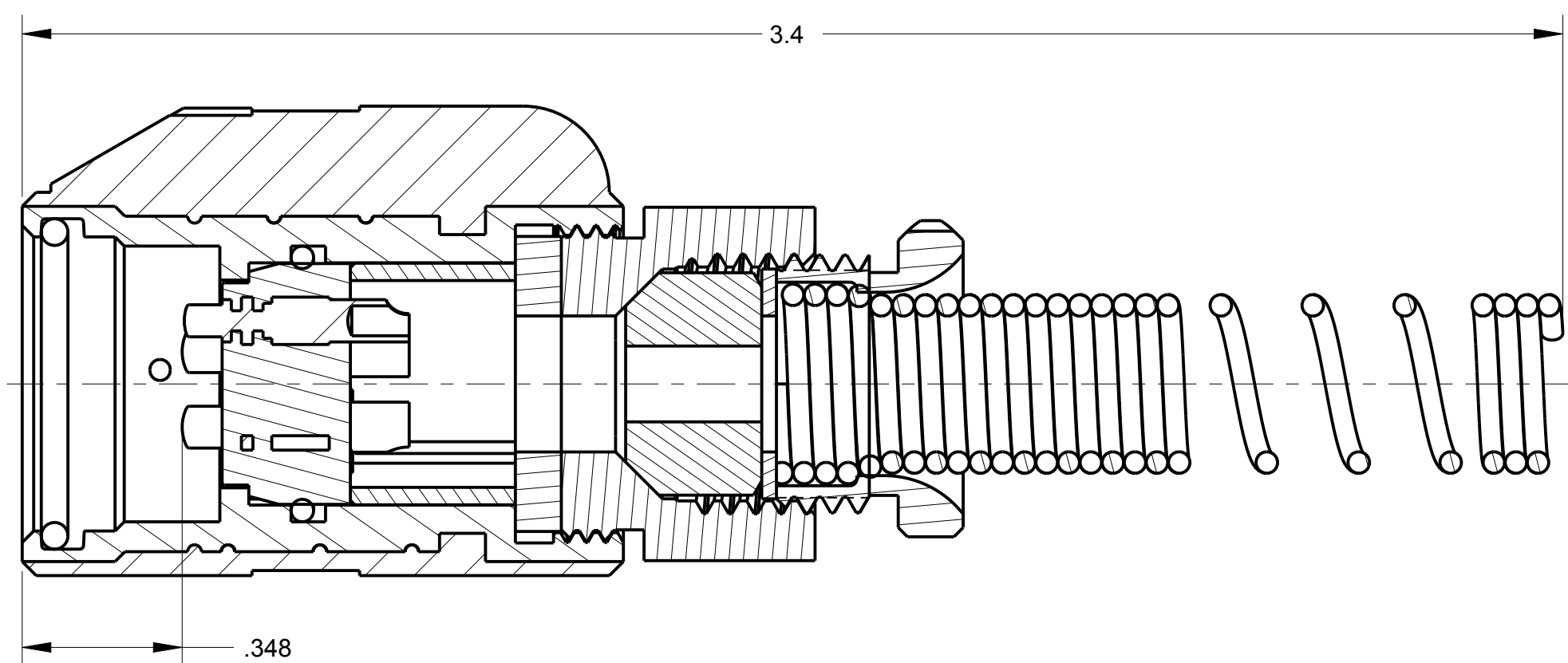
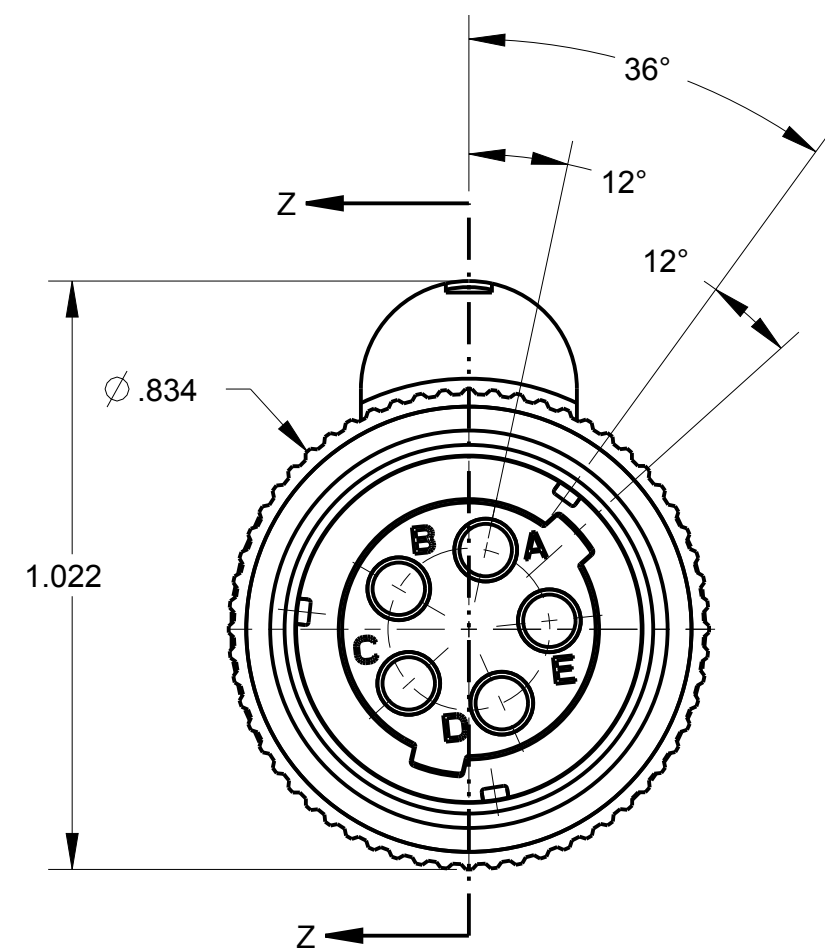
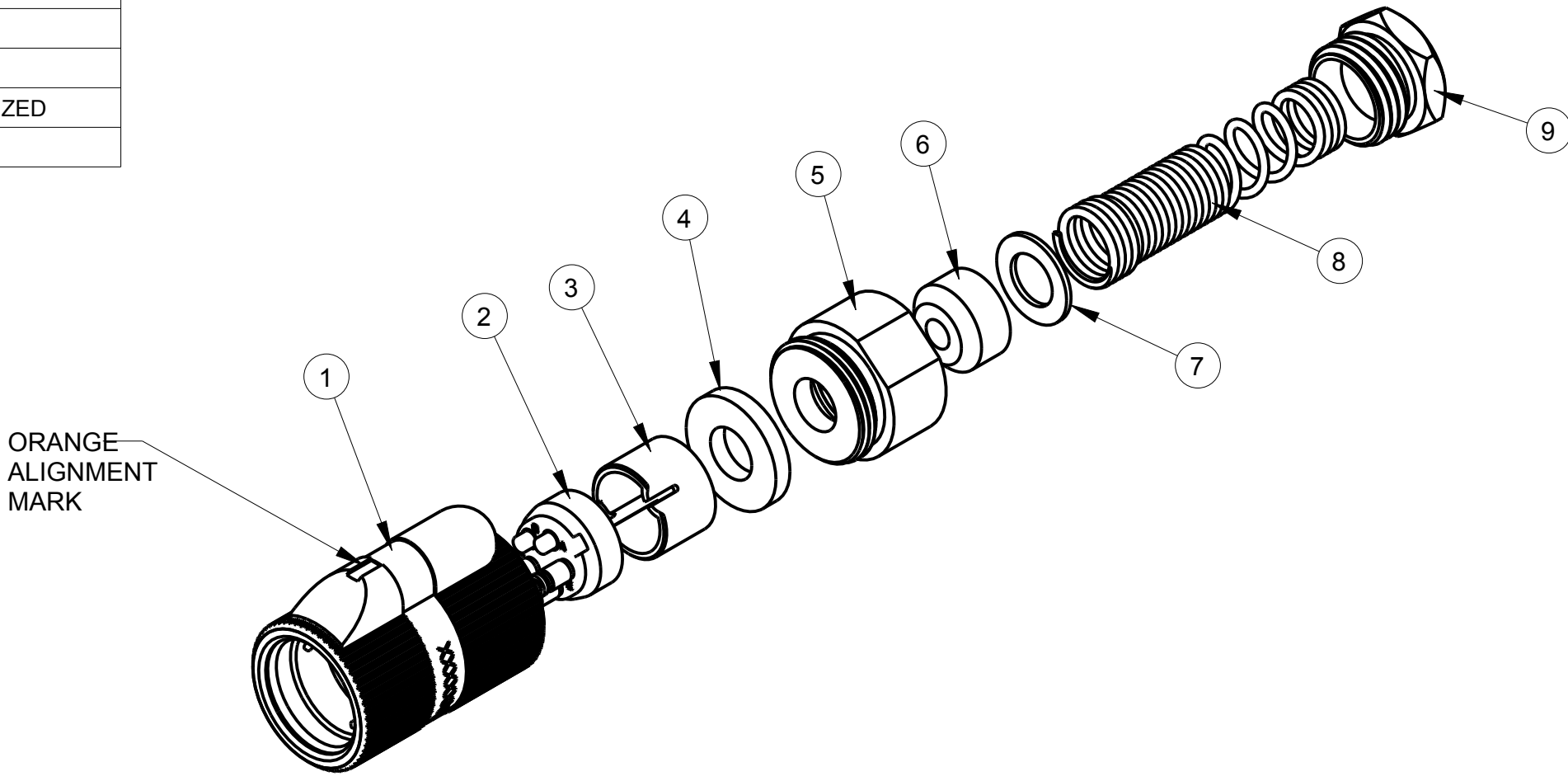

SECTION Z-Z

NOTES:
 1) UNLESS OTHERWISE SPECIFIED, CONNECTOR MEETS ALL GENERAL REQUIREMENTS & SPECIFICATIONS OF MIL-C-55116

THIS DOCUMENT CONTAINS PROPRIETARY INFORMATION OF NEXUS, INCORPORATED AND SUCH INFORMATION MAY NOT BE DISCLOSED TO OTHERS FOR ANY PURPOSE OR USED FOR ANY PURPOSE WITHOUT THE WRITTEN CONSENT OF NEXUS.

				DWN. BY	MNF	DATE	2/4/97	MATERIAL	
				CHECKED BY	L SMITH	DATE	9/9/97	FINISH	
				APPR. BY	L SMITH	DATE	9/9/97	WEIGHT	SCALE = 1.00 :1
				UNLESS OTHERWISE SPECIFIED: DIMENSIONS ARE IN INCHES & OR [mm]				TITLE	
				TOLERANCES:				AUDIO PLUG	
				DECIMAL: ±.XX[X.X] ±.003[0.08]				NEXUS STAMFORD, CONN	
				FRACTION: ±X/X ± 1/64				SIZE DWG. NO.	
				ANGLES: ±X ±.5				C AP-145	
				LET. REVISION CN # DATE CHK				DO NOT SCALE DWG. SHEET 1 OF 1	

B	ADD P/N'S IN P/L	101	2/25 2011	HR
A	REVISED & REDRAWN ON CAD	0259	2/24 1997	LS