

ITEM #	PART #	QTY	DESCRIPTION	MATERIAL
1	SEE TABLE #1	1	SHELL ASS'Y	GLASS FILLED NYLON & 303 SS
2	AP-146-6	1	INSERT ASS'Y	DIALLYPHTHALATE, TYPE SDGF & GOLD PLATED BRASS
3	AP-105-5	1	STRAIN RELIEF	NYLON
4	AP-116-3	1	WASHER	RUBBER
5	AP-116-7	1	NUT ADAPTER	ALUMINUM, ANODIZED
6	SEE TABLE #1	1	BUSHING	RUBBER
7	SEE TABLE #1	1	WASHER	STAINLESS STEEL
8	SEE TABLE #1	1	SPRING	302 STAINLESS STEEL
9	AP-116-6	1	STUD	ALUMINUM ALLOY, ANODIZED

C AP-146

TABLE #1						
AUDIO PLUG #	MILITARY PART #	SHELL ASS'Y	CABLE SIZE	BUSHING	WASHER	SPRING
AP-146/4-1	M55116/4-1	AP-146-1	∅ .185 ± .010	AP-116-17	AP-116-2	AP-116-4
AP-146/4-2	M55116/4-2	AP-146-2	∅ .228 ± .010	AP-116-18	AP-116-2	AP-116-4
AP-146/4-3	M55116/4-3	AP-146-3	∅ .250 ± .010	AP-116-8	AP-116-2	AP-116-4
AP-146/4-4	M55116/4-4	AP-146-4	∅ .290 ± .010	AP-116-19	AP-116-2	AP-116-4
AP-146/4-5	M55116/4-5	AP-146-5	∅ .320 ± .010	AP-116-20	AP-116-22	AP-116-21

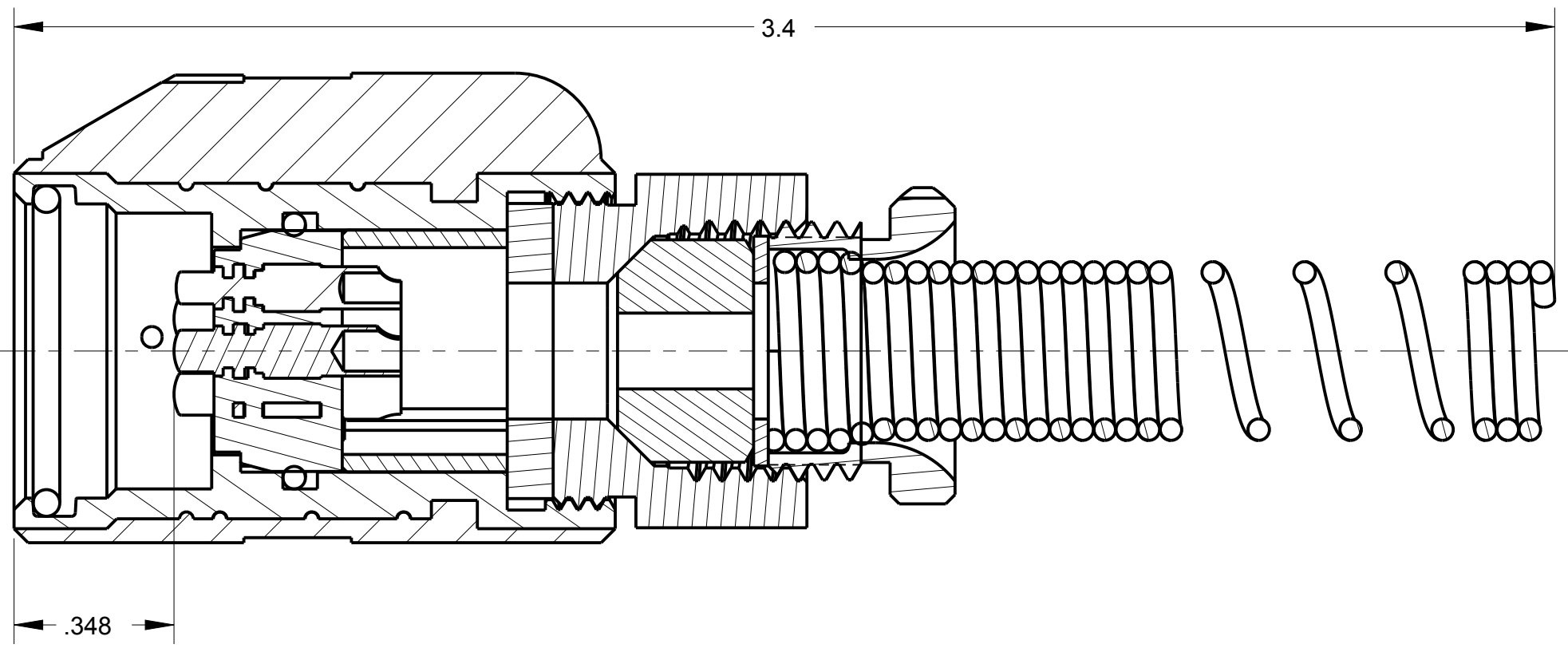
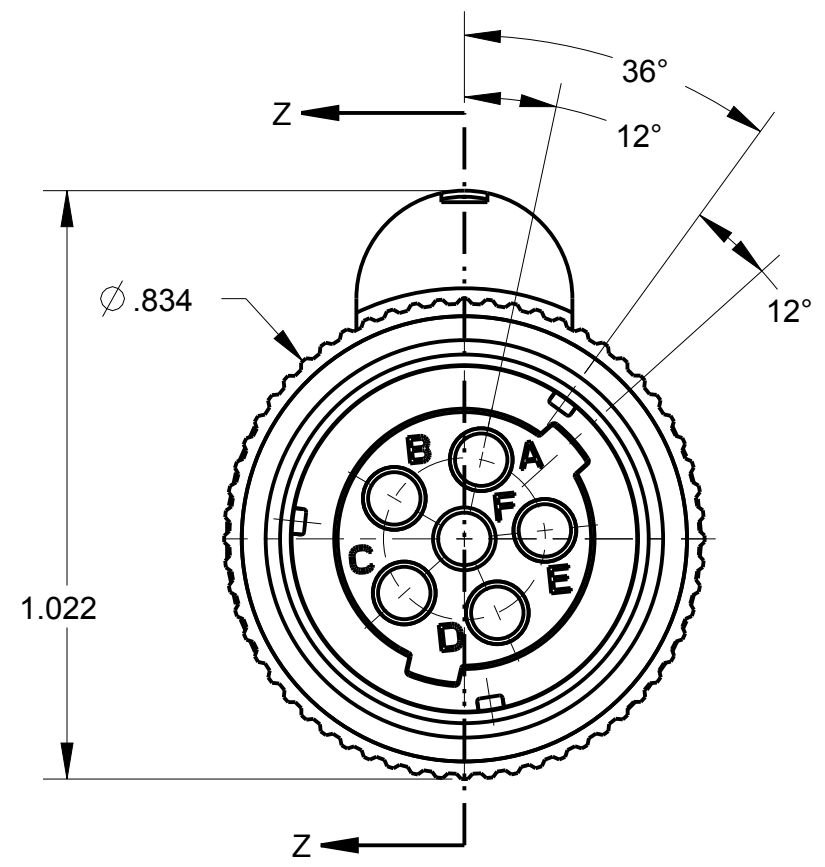
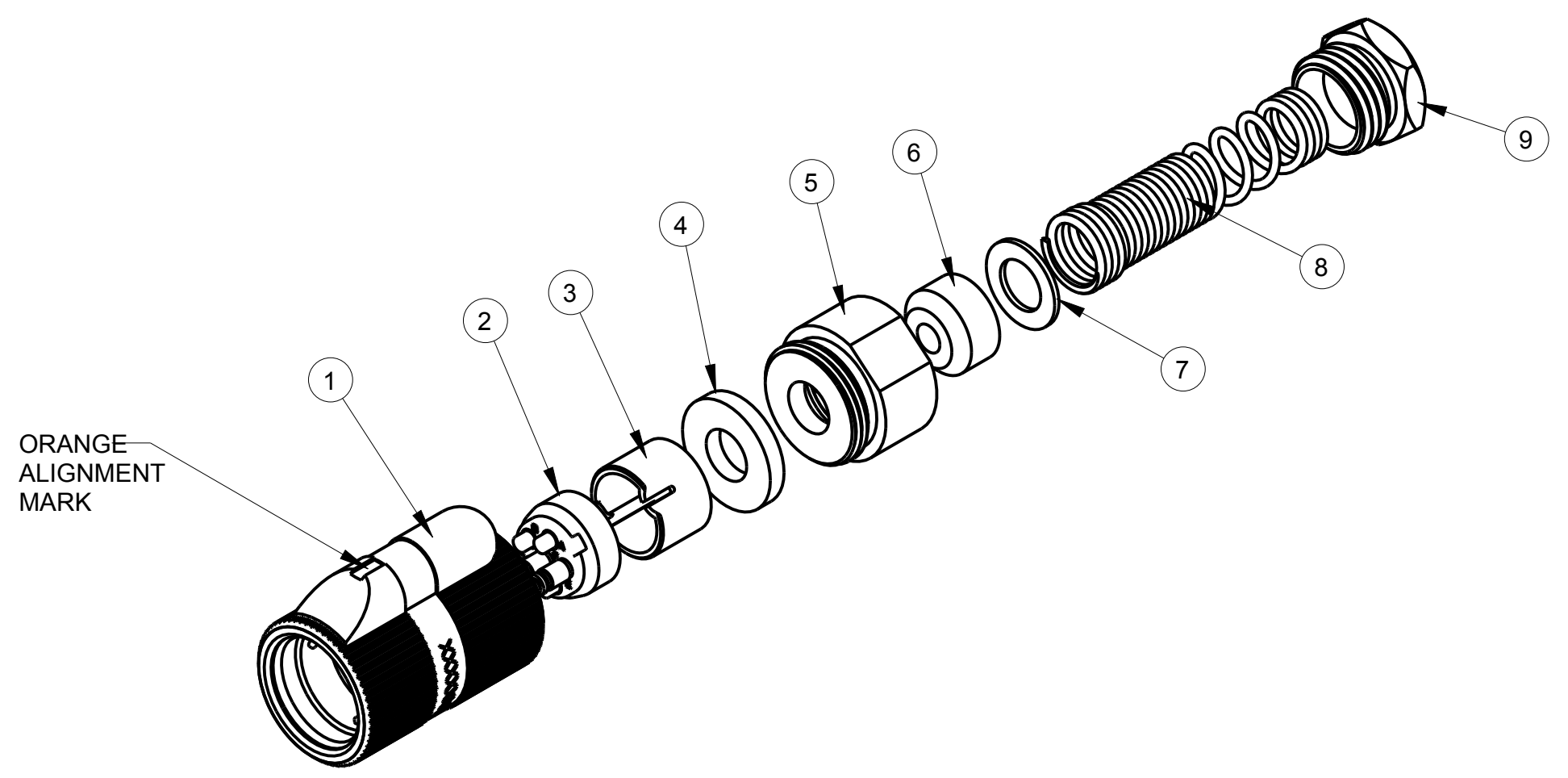

NOTES:
1) UNLESS OTHERWISE SPECIFIED, CONNECTOR MEETS ALL GENERAL REQUIREMENTS & SPECIFICATIONS OF MIL-C-55116

THIS DOCUMENT CONTAINS PROPRIETARY INFORMATION OF NEXUS, INCORPORATED AND SUCH INFORMATION MAY NOT BE DISCLOSED TO OTHERS FOR ANY PURPOSE OR USED FOR ANY PURPOSE WITHOUT THE WRITTEN CONSENT OF NEXUS.

DWN.BY MNF		DATE 2/4/97		MATERIAL	
CHECKED BY L SMITH		DATE 9/9/97		FINISH	
APPR.BY L SMITH		DATE 9/9/97		WEIGHT	SCALE = 1.00 :1
UNLESS OTHERWISE SPECIFIED: DIMENSIONS ARE IN INCHES &/OR (mm)				TITLE	
TOLERANCES:				AUDIO PLUG	
DECIMAL: ±.XX(X) ±.01(0.3)				NEXUS STAMFORD, CONN	
FRACTION: ±X/X ± 1/64				SIZE DWG. NO.	
ANGLES: ±X ±.5				C AP-146	
DO NOT SCALE DWG.		SHEET 1 OF 1			

LET.	REVISION	CN #	DATE	CHK
B	ADD P/N'S IN P/L	101	2/25 2011	HR
A	REVISED & REDRAWN ON CAD	0259	2/24 1997	LS