

ITEM #	PART #	QTY	DESCRIPTION	MATERIAL
1	AP-175-1	1	SHELL ASS'Y	GLASS FILLED NYLON & 303 SS
2	AP-145-6	1	INSERT ASS'Y	DIALLYPHTHALATE, TYPE SDGF & GOLD PLATED BRASS
3	AP-105-5	1	STRAIN RELIEF	NYLON
4	AP-116-3	1	WASHER	RUBBER
5	AP-136-8	1	NUT ADAPTER	ALUMINUM, BLACK CHROME
6	AP-136-6	1	CLAMP SHIELD, OUTER	NICKEL PLATED BRASS
7	AP-136-5	1	CLAMP SHIELD INNER	NICKEL PLATED BRASS
8	AP-116-8	1	BUSHING	RUBBER
9	AP-116-2	1	WASHER	STAINLESS STEEL
10	AP-116-4	1	SPRING	302 STAINLESS STEEL
11	AP-116-6	1	STUD	ANODIZED ALUMINUM ALLOY

C AP-175

NOTES:
 1) UNLESS OTHERWISE SPECIFIED, CONNECTOR MEETS ALL GENERAL REQUIREMENTS & SPECIFICATIONS OF MIL-C-55116

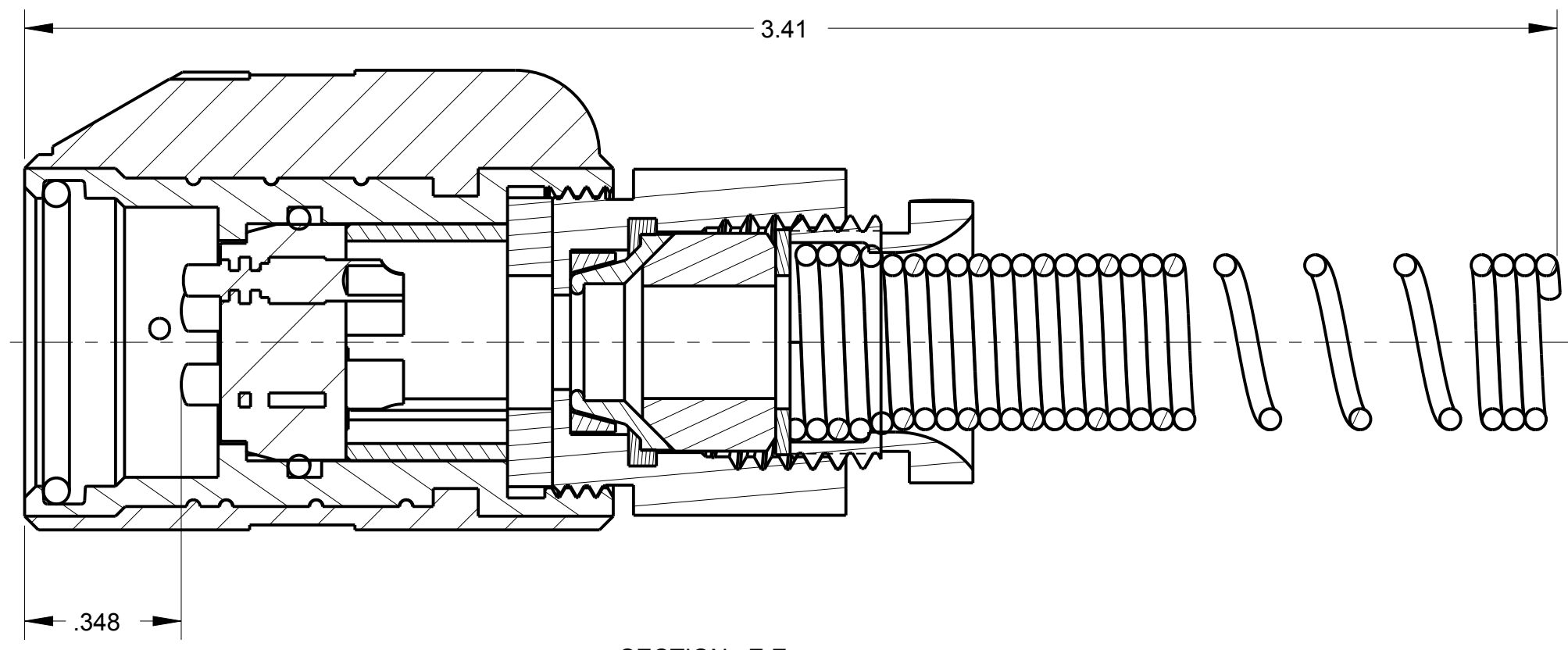
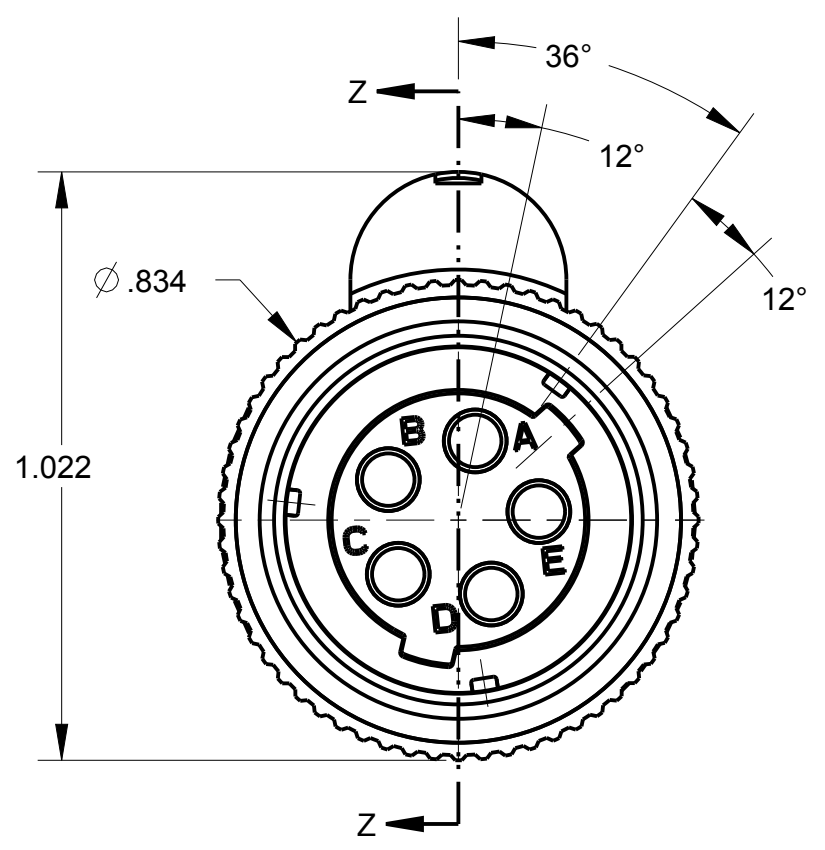
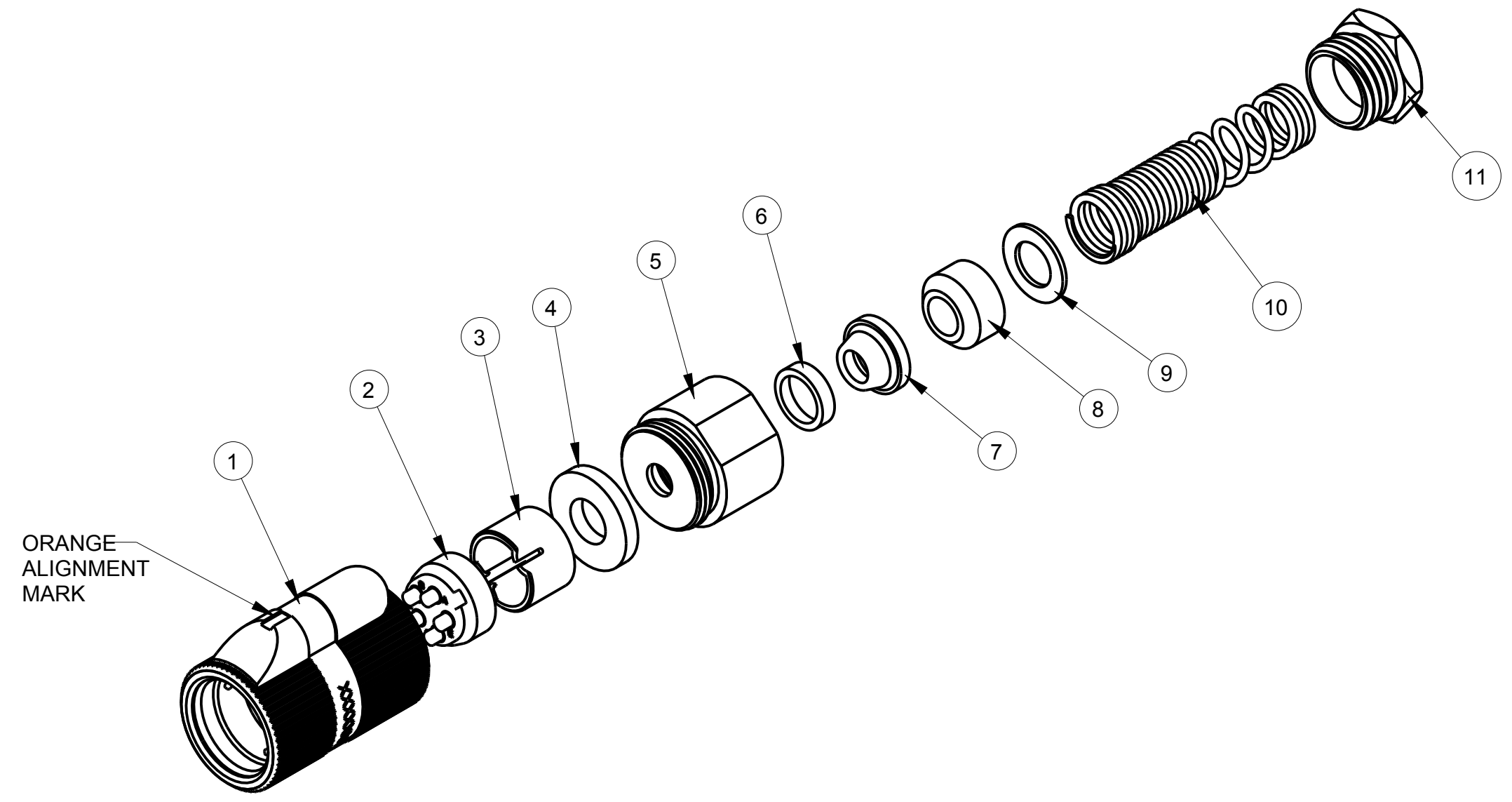

SECTION Z-Z

THIS DOCUMENT CONTAINS PROPRIETARY INFORMATION OF NEXUS, INCORPORATED AND SUCH INFORMATION MAY NOT BE DISCLOSED TO OTHERS FOR ANY PURPOSE OR USED FOR ANY PURPOSE WITHOUT THE WRITTEN CONSENT OF NEXUS.

DWN. BY: MNF		DATE: 2/6/97		MATERIAL	
CHECKED BY: L SMITH		DATE: 9/10/97		FINISH	
APPR. BY: L SMITH		DATE: 9/10/97		WEIGHT	SCALE = 1.00 :1
UNLESS OTHERWISE SPECIFIED DIMENSIONS ARE IN INCHES & OR [mm]				TITLE	
TOLERANCES:				AUDIO PLUG SHIELDED	
DECIMAL: ±.XX[X.X] ±.01[0.3]				±.XXX[XX] ±.003[0.08]	
FRACTION: ±XXX ± 1/64				ANGLES: ±X ° ±5 °	
B ADD P/N'S TO P/L		101	2/25 2011	HR	NEXUS STAMFORD, CONN
A REVISED & REDRAWN ON CAD		0259	2/24 1997	LS	
LET.	REVISION	CN #	DATE	CHK	SIZE DWG. NO.
					C AP-175
				DO NOT SCALE DWG.	SHEET 1 OF 1