

ITEM #	PART #	QTY	DESCRIPTION	MATERIAL
1	AP-145-1M	1	SHELL ASS'Y	303 STAINLESS STEEL
2	AP-146-6	1	INSERT ASS'Y	DIALYPHTHALATE, TYPE SDGF & GOLD PLATED BRASS
3	AP-105-5	1	STRAIN RELIEF	NYLON
4	AP-116-3	1	WASHER	RUBBER
5	AP-136-8	1	NUT ADAPTER	BRASS, BLACK CHROME
6	AP-136-6	1	CLAMP SHIELD, OUTER	NICKEL PLATED BRASS
7	AP-136-5	1	CLAMP SHIELD INNER	NICKEL PLATED BRASS
8	SEE TABLE #1	1	BUSHING	RUBBER
9	SEE TABLE #1	1	WASHER	STAINLESS STEEL
10	SEE TABLE #1	1	SPRING	302 STAINLESS STEEL
11	AP-116-6	1	STUD	ANODIZED ALUMINUM ALLOY

C AP-176M-CP

TABLE #1				
PART #	Ø CABLE	BUSHING	WASHER	SPRING
AP-176M-01	Ø .165 ± .010	AP-116-17	AP-116-2	AP-116-4
AP-176M-02	Ø .228 ± .010	AP-116-18	AP-116-2	AP-116-4
AP-176M	Ø .250 ± .010	AP-116-8	AP-116-2	AP-116-4
AP-176M-04	Ø .290 ± .010	AP-116-19	AP-116-2	AP-116-4
AP-176M-05	Ø .320 ± .010	AP-116-20	AP-116-22	AP-116-21

NOTES:  
1) UNLESS OTHERWISE SPECIFIED, CONNECTOR MEETS ALL GENERAL REQUIREMENTS & SPECIFICATIONS OF MIL-C-55116

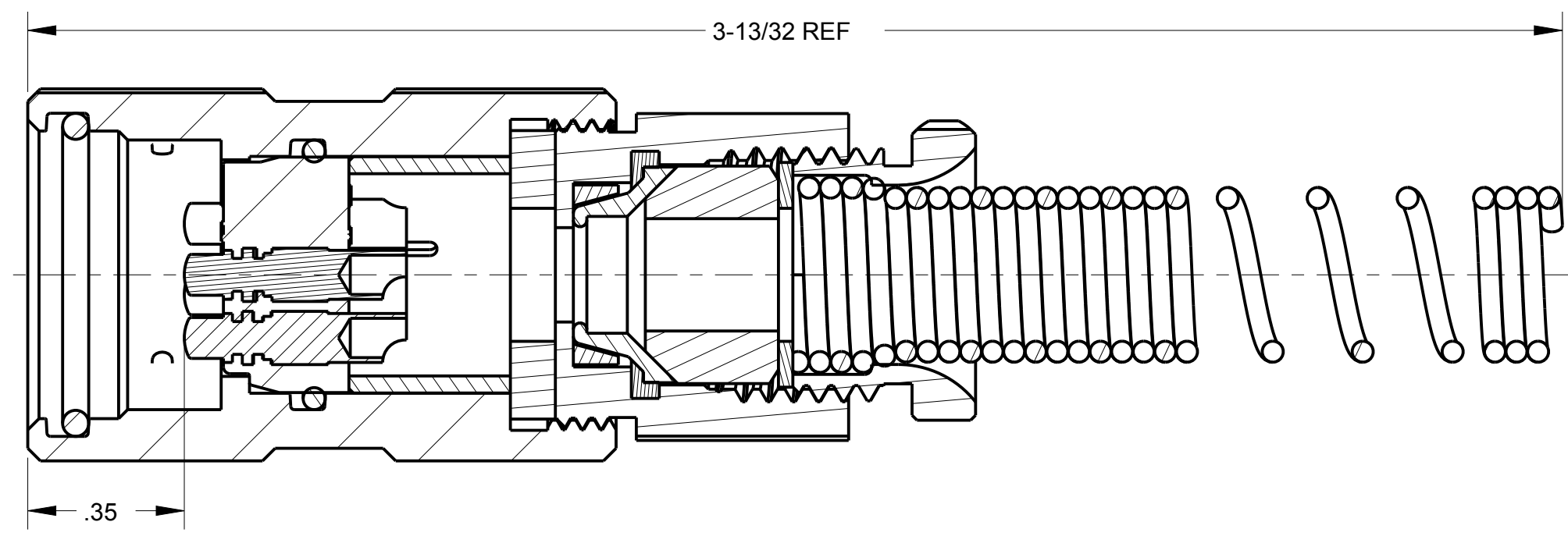
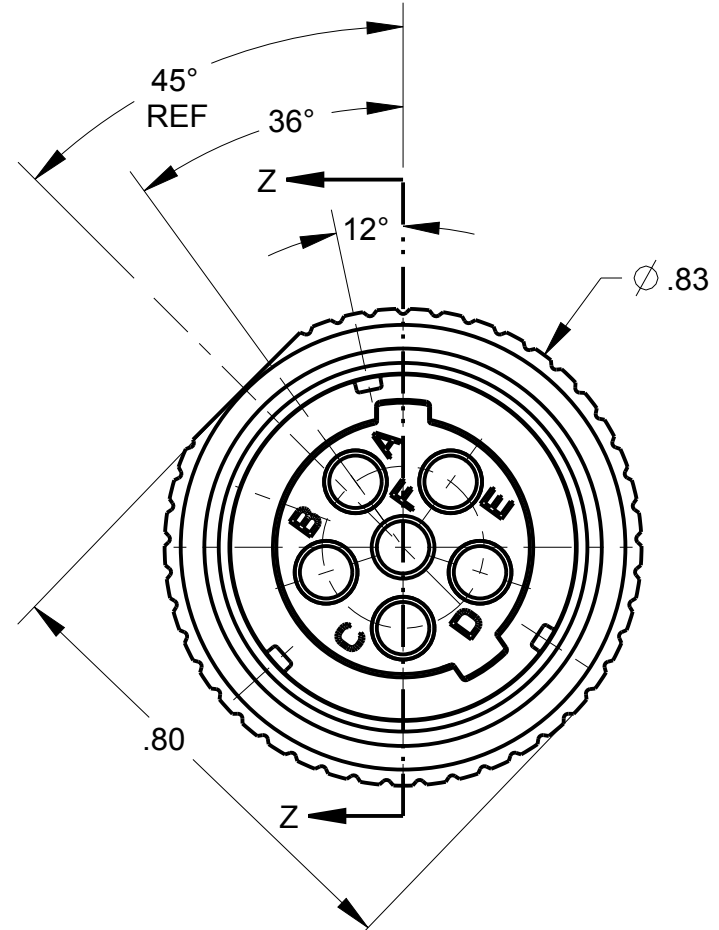
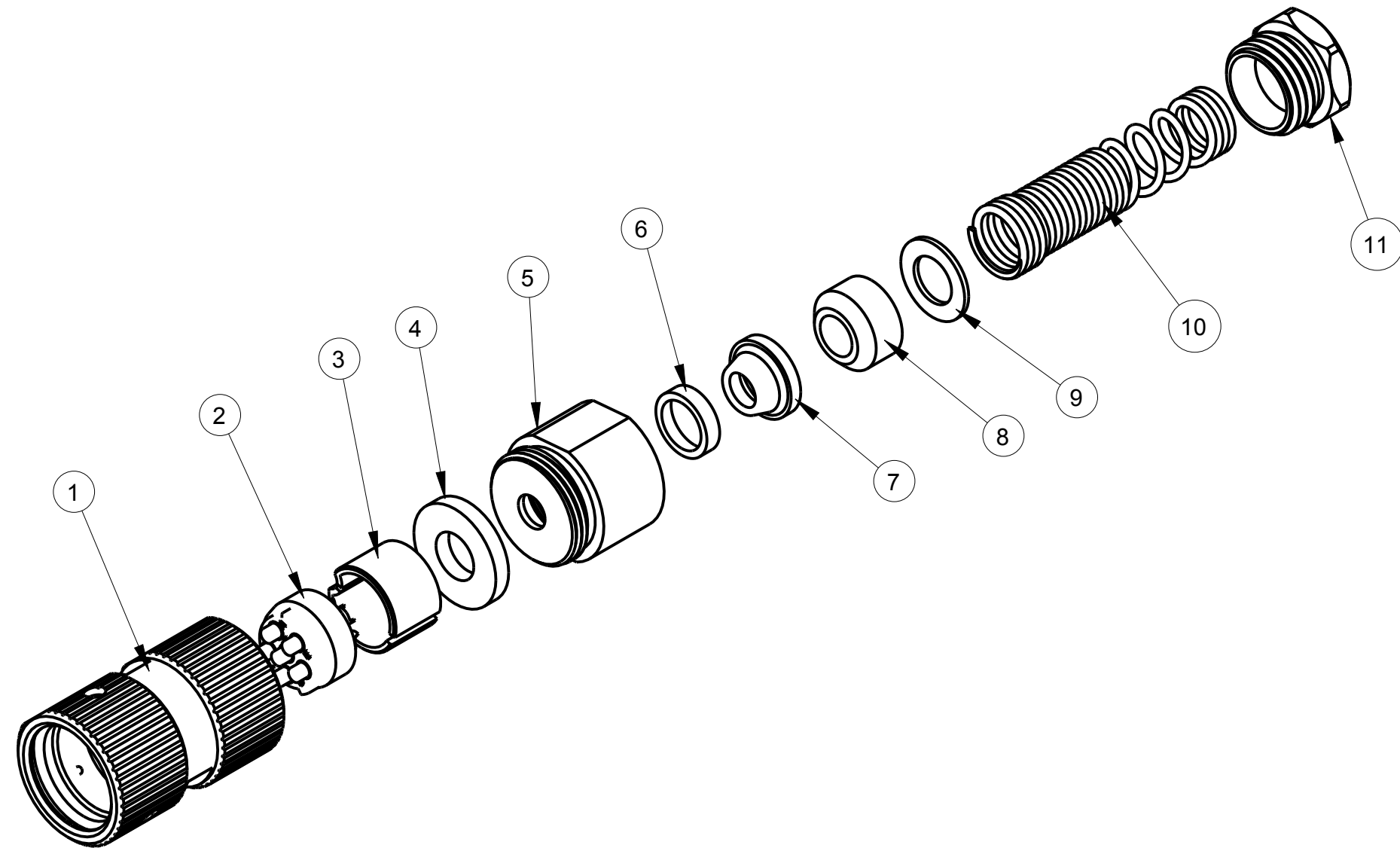

SECTION Z-Z

THIS DOCUMENT CONTAINS PROPRIETARY INFORMATION OF NEXUS, INCORPORATED AND SUCH INFORMATION MAY NOT BE DISCLOSED TO OTHERS FOR ANY PURPOSE OR USED FOR ANY PURPOSE WITHOUT THE WRITTEN CONSENT OF NEXUS.

E	CHG: ITEM #5 MAT'L	202	8/9 2014	HR	DWN.BY GPH	DATE 2/24/10	MATERIAL		
D	ADD P/Ns TO P/L	101	2/25 2011	HR	CHECKED BY GPH	DATE 2/24/10	FINISH		
C	REMOVE "NEXUS" FROM VIEW	059	4/21 2010	GPH	APPR.BY GPH	DATE 2/24/10	WEIGHT _____ SCALE = 1.00 :1		
B	B1) WAS NUT ADAPTER AP-136-4 B2) WAS SHELL INSERT KNURLED AP-136-3M B3) WAS O-RING AP-105-3 B4) WAS O-RING AP-105-2	058	4/13 2010	GPH	UNLESS OTHERWISE SPECIFIED DIMENSIONS ARE IN INCHES & OR (mm)		TITLE		
A	RELEASED FOR PRODUCTION	048	2/24 2010	GPH	TOLERANCES: DECIMAL: ±.XX(X.X) ±.XXX(X.XX) ±.XXXX(X.XXX) ±.0X(0.X) ±.00X(0.0X) ±.000X(0.0XX)		<b>NEXUS</b> STAMFORD, CONN SIZE DWG. NO. C AP-176M-CP		
F	DEL: 10° ; 33° ; 2.1± .1, ADD: 12° ; 36° ; 45° REF	226	8/31 2015	HR	FRACTION: ±X/XX ±.XXX ±.X	ANGLES: ±X° ±.X°		DO NOT SCALE DWG. SHEET 1 OF 1	
LET	REVISION	CN #	DATE	CHK	LET	REVISION	CN #	DATE	CHK