

ITEM	PART #	QTY	DESCRIPTION	MATERIAL
1	SEE TABLE #1	1	WASHER	STAINLESS STEEL
2	SEE TABLE #1	1	SPRING	302 STAINLESS STEEL
3	AP-116-6	1	STUD	ANODIZED ALUMINUM ALLOY
4	SEE TABLE #1	1	BUSHING	RUBBER
5	AP-136-35	1	PLUG HSG MOLDING	GLASS FILLED NYLON & 303 SS
6	AP-136-30	1	CAP	ALUMINUM & BLACK CHROME
7	AP-136-31	1	ADAPTER - 90°	BRASS & BLACK CHROME
8	AP-136-33	1	STRAIN RELIEF	NYLON
9	AP-136-36	2	O-RING	ETHYLENE PROPYLENE
10	AP-136-41	1	O-RING	ETHYLENE PROPYLENE
11	AP-136-5	1	CLAMP SHELL (INNER)	BRASS WITH NICKEL PLATING
12	AP-136-6	1	CLAMP INNER (OUTER)	BRASS WITH NICKEL PLATING
13	AP-136-7	1	GASKET	RUBBER
14	AP-146-6	1	INSERT	DIALYLPHTHALATE, TYPE SDGF & GOLD PLATED BRASS

C AP-176RA-CP

TABLE #1				
AUDIO PLUG #	CABLE Ø	BUSHING	WASHER	SPRING
AP-176RA/1	Ø .165 ± .010	AP-116-17	AP-116-2	AP-116-4
AP-176RA/2	Ø .228 ± .010	AP-116-18	AP-116-2	AP-116-4
AP-176RA	Ø .250 ± .010	AP-116-8	AP-116-2	AP-116-4
AP-176RA/4	Ø .290 ± .010	AP-116-19	AP-116-2	AP-116-4
AP-176RA/5	Ø .320 ± .010	AP-116-20	AP-116-22	AP-116-21

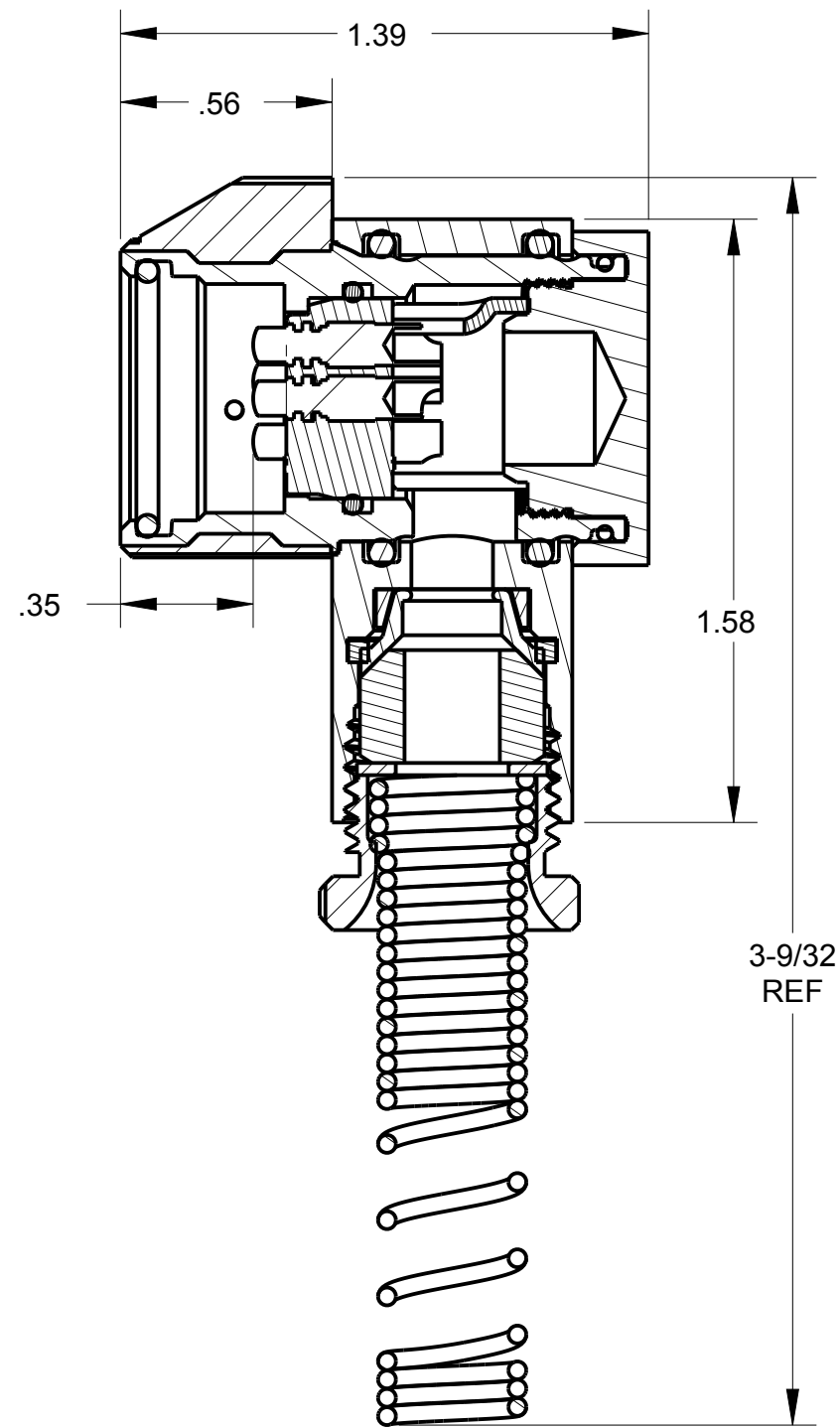
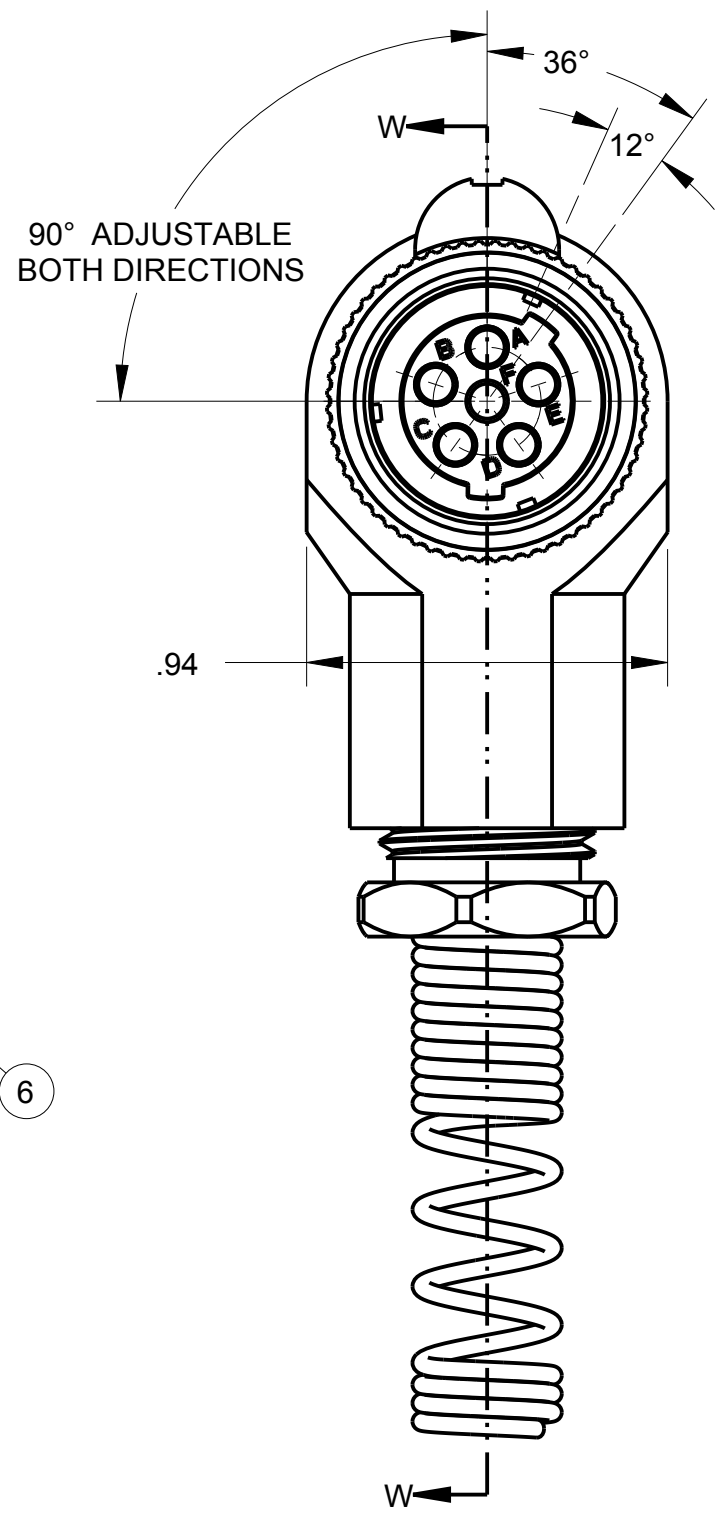
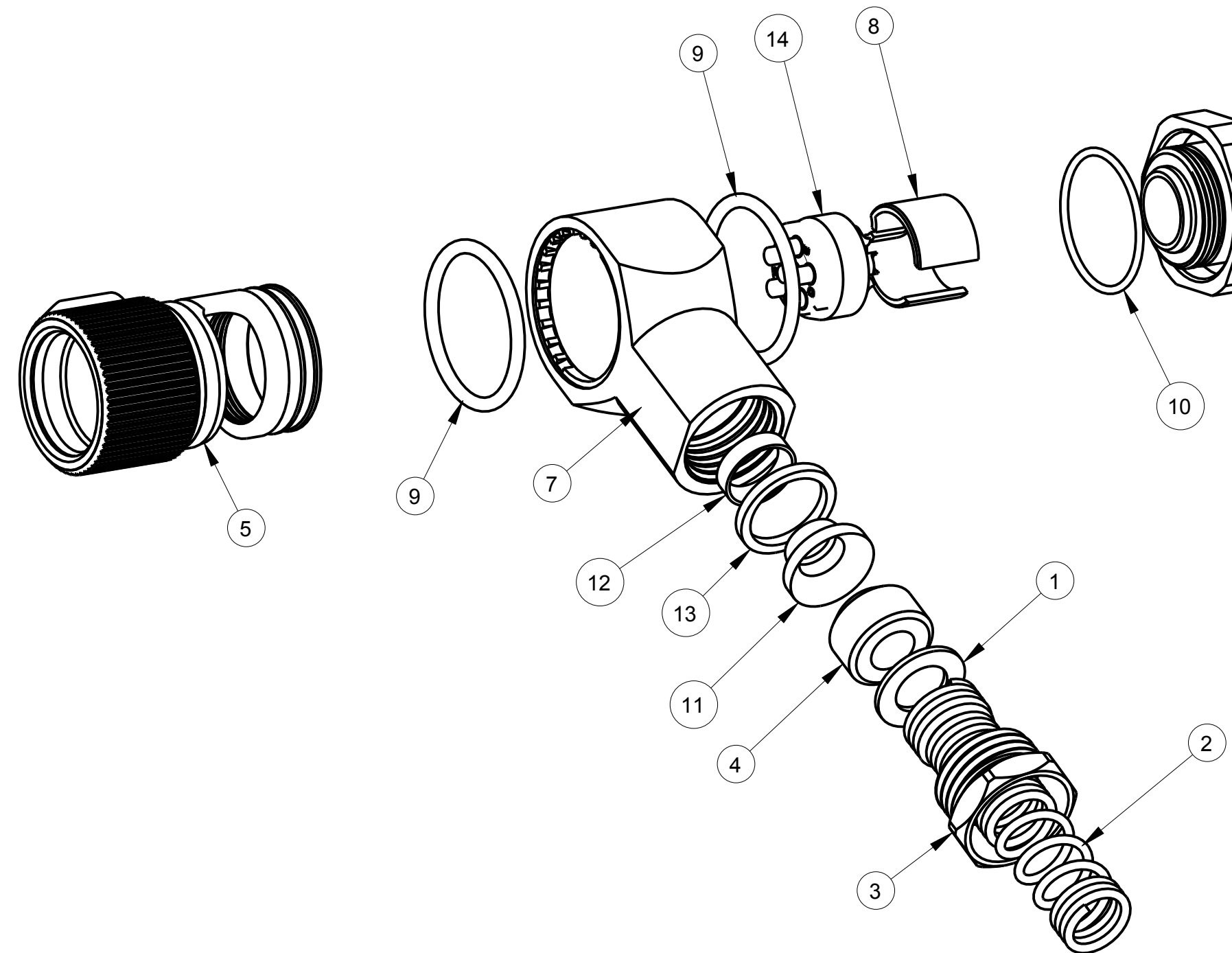

SECTION W-W

THIS DOCUMENT CONTAINS PROPRIETARY INFORMATION OF NEXUS, INCORPORATED AND SUCH INFORMATION MAY NOT BE DISCLOSED TO OTHERS FOR ANY PURPOSE OR USED FOR ANY PURPOSE WITHOUT THE WRITTEN CONSENT OF NEXUS.

DWN. BY		HR	DATE		3/2/11		MATERIAL	
CHECKED BY			DATE				FINISH	
APPR. BY			DATE				WEIGHT	SCALE = 1.00 :1
C		ADD: 12°; 36° CHG: 3 APPROX TO 3-9/32 REF	226	9/15 2015	HR	TITLE AUDIO PLUG - 90		
B		ADD: TABLE #1(D-1)	212	9/15 2014	HR			
A		RELEASED		3/2 2011	HR	DO NOT SCALE DWG. SHEET 1 OF 1		
LET.		REVISION	CN #	DATE	CHK	FRACTION: ±XXX ±XXX		SIZE C
						UNLESS OTHERWISE SPECIFIED DIMENSIONS ARE IN INCHES & OR (mm)		NEXUS STAMFORD, CONN. DWG. NO. AP-176RA-CP
						TOLERANCES: DECIMAL: ±.XX(X.X) ±.XXX(X.XX) ±.XXXX(X.XXX) ±.0X(0.X) ±.00X(0.0X) ±.000X(0.0XX) ANGLES: ±X° ±X'		