

CONSTANT VOLTAGE AND CONSTANT CURRENT CONTROLLER

Description

The AP4313 is a highly integrated solution for a constant voltage/constant current mode SMPS application.

The AP4313 contains one 1.21V voltage reference with ±1% accuracy, one current sensing circuit and two operational amplifiers. Combining the voltage reference with one operational amplifier makes AP4313 an ideal voltage controller for use in adapters and battery chargers. The other low voltage reference combined with the other operational amplifier makes it an ideal current limiter for output low side current sensing.

The AP4313 is available in SOT26 package.

Features

- Constant Voltage and Constant Current Control
- Precision Internal Voltage Reference
- Few External Components
- Easy Compensation
- Low Supply Current: 0.5mA
- Operating Temperature Range: -40 to +105°C
- **Totally Lead-free & Fully RoHS Compliant (Notes 1 & 2)**
- **Halogen and Antimony Free. "Green" Device (Note 3)**

- Notes:
1. No purposely added lead. Fully EU Directive 2002/95/EC (RoHS) & 2011/65/EU (RoHS 2) compliant.
 2. See http://www.diodes.com/quality/lead_free.html for more information about Diodes Incorporated's definitions of Halogen- and Antimony-free, "Green" and Lead-free.
 3. Halogen- and Antimony-free "Green" products are defined as those which contain <900ppm bromine, <900ppm chlorine (<1500ppm total Br + Cl) and <1000ppm antimony compounds.

Pin Assignments

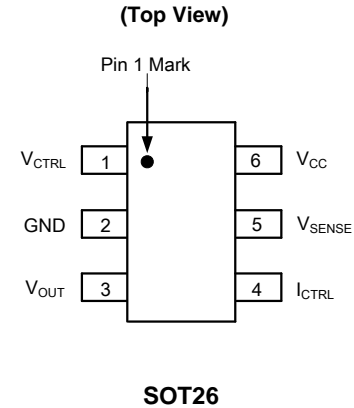

Applications

- Adapters
- Battery Chargers

Typical Applications Circuit

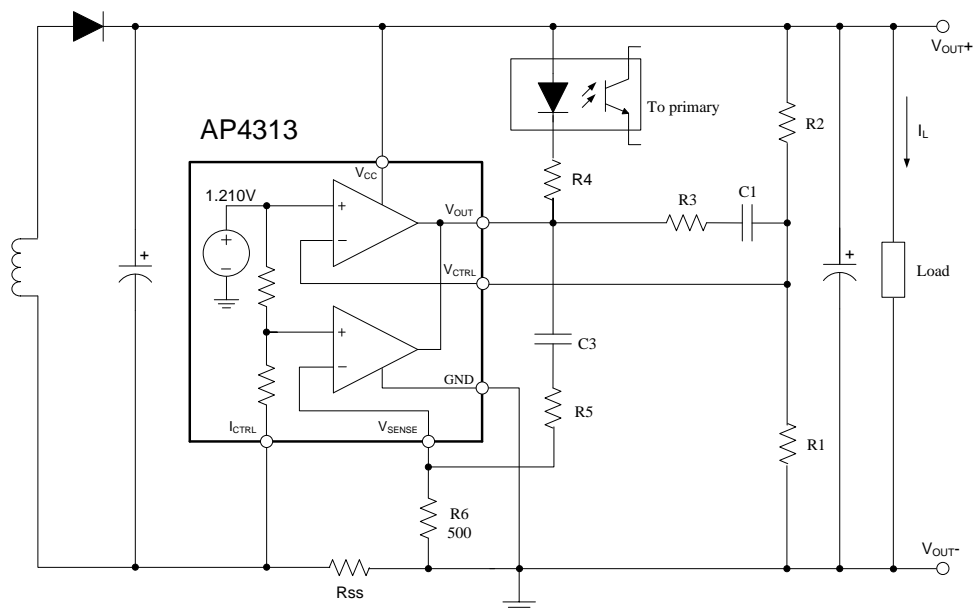

$$V_{OUT} = V_{REF} \times \frac{R1 + R2}{R1} \text{ (V)}$$

$$CurrentLimit = \frac{V_{SENSE}}{R_{SS}} \text{ (A)}$$

Typical Application 1

Typical Applications Circuit (Cont.)

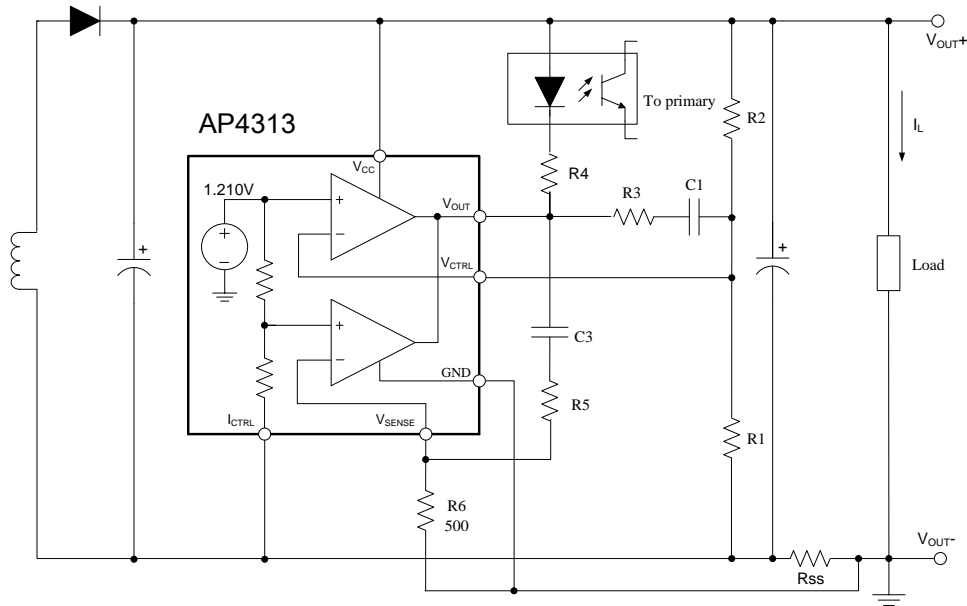

$$V_{OUT} = [V_{REF} + (I_L \times R_{SS})] \times \frac{R1 + R2}{R1} - (I_L \times R_{SS}) \text{ (V)}$$

$$\text{CurrentLimit} = \frac{V_{SENSE}}{R_{SS}} \text{ (A)}$$

Typical Application 2

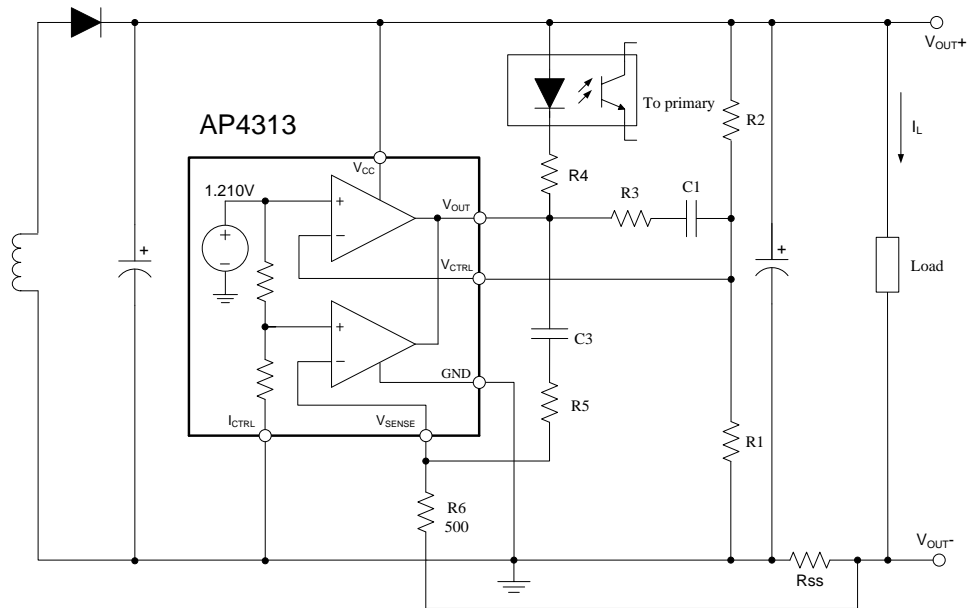

$$V_{OUT} = V_{REF} \times \frac{R1 + R2}{R1} - (I_L \times R_{SS}) \text{ (V)}$$

$$\text{CurrentLimit} = \frac{V_{SENSE} \times V_{REF}}{(V_{SENSE} + V_{REF}) \times R_{SS}} \text{ (A)}$$

Typical Application 3

Pin Descriptions

Pin Number	Pin Name	Function
1	V_{CTRL}	Input pin of the voltage control loop
2	GND	Ground
3	V_{OUT}	Output pin. Sinking current only
4	I_{CTRL}	Input pin of the current control loop
5	V_{SENSE}	Input pin of the current control loop
6	V_{CC}	Power supply

Functional Block Diagram

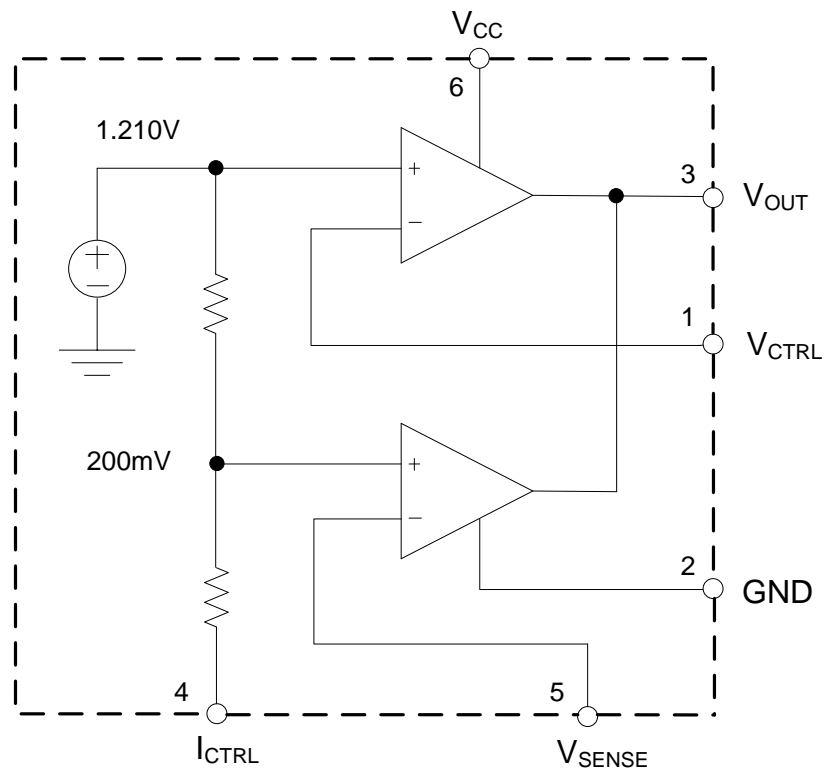

Absolute Maximum Ratings (Note 4)

Symbol	Parameter	Rating	Unit
V_{CC}	Power Supply Voltage	20	V
V_{IN}	Input Voltage	-0.3 to V_{CC}	V
T_J	Junction Temperature	+150	°C
T_{STG}	Storage Temperature	-65 to +150	°C
T_{LEAD}	Lead Temperature (Soldering, 5 sec)	+260	°C
θ_{JC}	Package Thermal Resistance (Junction to Case)	92	°C/W

Note 4: Stresses greater than those listed under "Absolute Maximum Ratings" may cause permanent damage to the device. These are stress ratings only, and functional operation of the device at these or any other conditions beyond those indicated under "Recommended Operating Conditions" is not implied. Exposure to "Absolute Maximum Ratings" for extended periods may affect device reliability.

Recommended Operating Conditions

Symbol	Parameter	Min	Max	Unit
V_{CC}	Power Supply Voltage	2.5	18	V
T_A	Operating Temperature Range	-40	+105	°C

Electrical Characteristics ($V_{CC}=5V$, $T_A=+25^\circ C$, unless otherwise specified.)

Symbol	Parameter	Conditions	Min	Typ	Max	Unit
TOTAL CURRENT CONSUMPTION						
I_{CC}	Total Supply Current Not Including the Output Sinking Current	–	–	0.6	1.2	mA
VOLTAGE CONTROL LOOP						
G_{mv}	Transconduction Gain (V_{CTRL}). Sink Current Only	–	1	3.5	–	mA/mV
V_{REF}	Voltage Control Loop Reference	–	1.198	1.21	1.222	V
I_{IBV}	Input Bias Current (V_{CTRL})	–	–	50	–	nA
CURRENT CONTROL LOOP						
G_{mi}	Transconduction Gain (I_{CTRL})	–	1.5	7	–	mA/mV
V_{SENSE}	Current Control Loop Reference	$I_{OUT}=2.5mA$	196	200	204	mV
I_{IBI}	Current Out of Pin I_{CTRL} at -200mV	–	–	25	–	μA
OUTPUT STAGE						
V_{OL}	Low Output Voltage at 10mA Sinking Current	–	–	200	–	mV
I_{OS}	Output Short Circuit Current. Output to V_{CC} . Sink Current Only	–	–	27	50	mA

Performance Characteristics

V_{REF} vs. Ambient Temperature

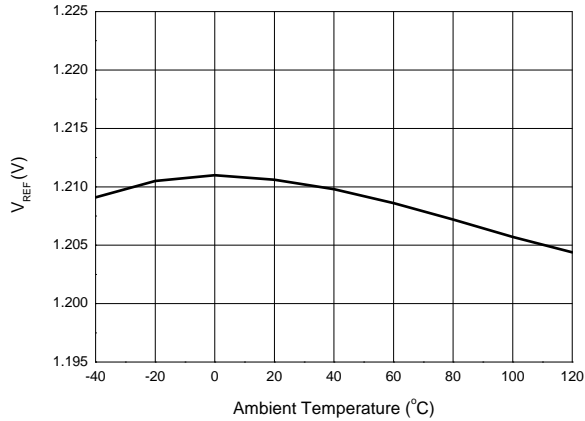

V_{SENSE} vs. Ambient Temperature

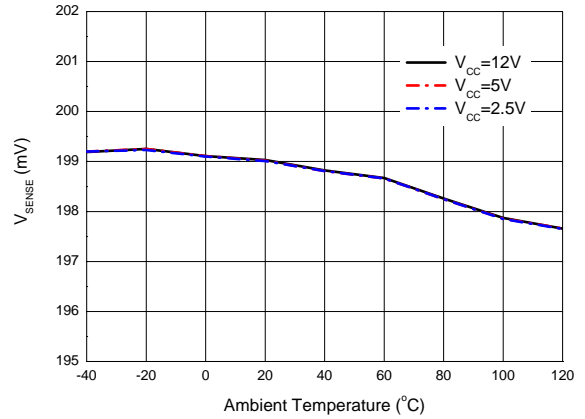

V_{CTRL} Pin Input Bias Current vs. Ambient Temperature

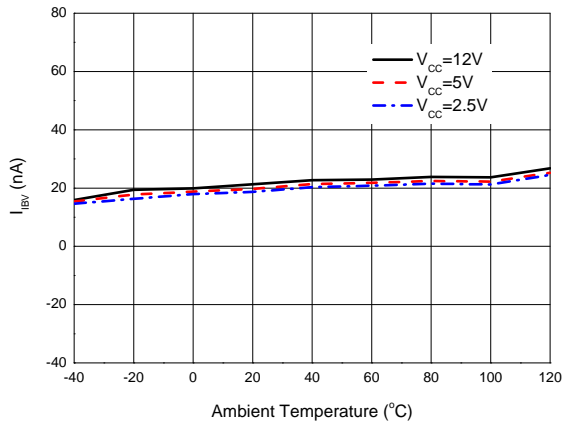

I_{CTRL} Pin Input Bias Current vs. Ambient Temperature

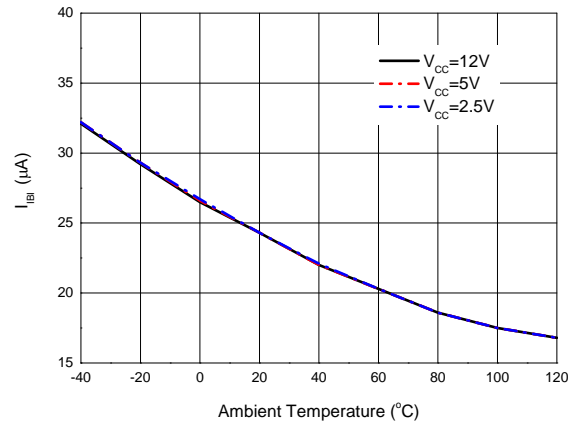

Output Short Circuit Current vs. Ambient Temperature

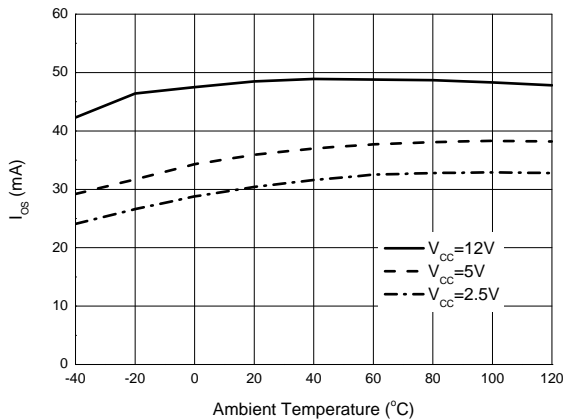

Supply Current vs. Ambient Temperature

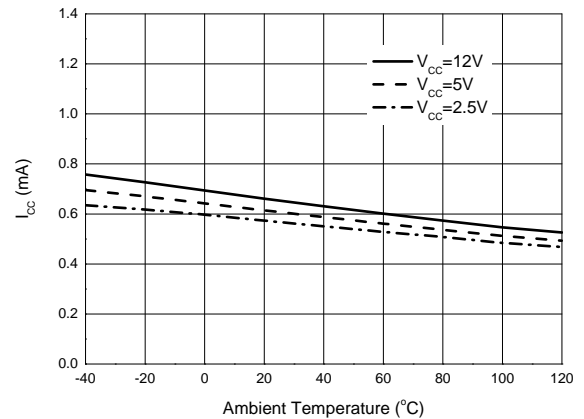

Ordering Information

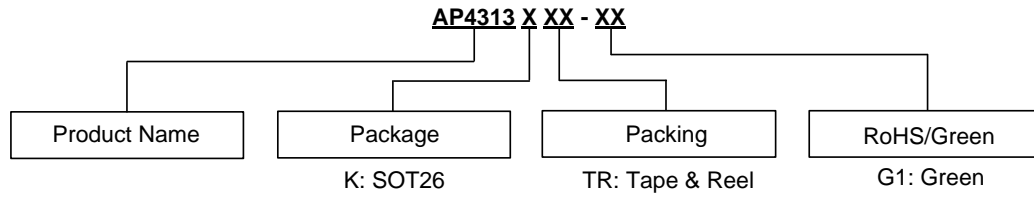

Package	Temperature Range	Part Number	Marking ID	Packing
SOT26	-40 to +105°C	AP4313KTR-G1	G6G	3000/Tape & Reel

Marking Information

(Top View)

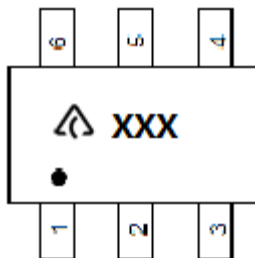

 : Logo
 XXX: Marking ID

Package Outline Dimensions (All dimensions in mm(inch).)

(1) Package Type: SOT26

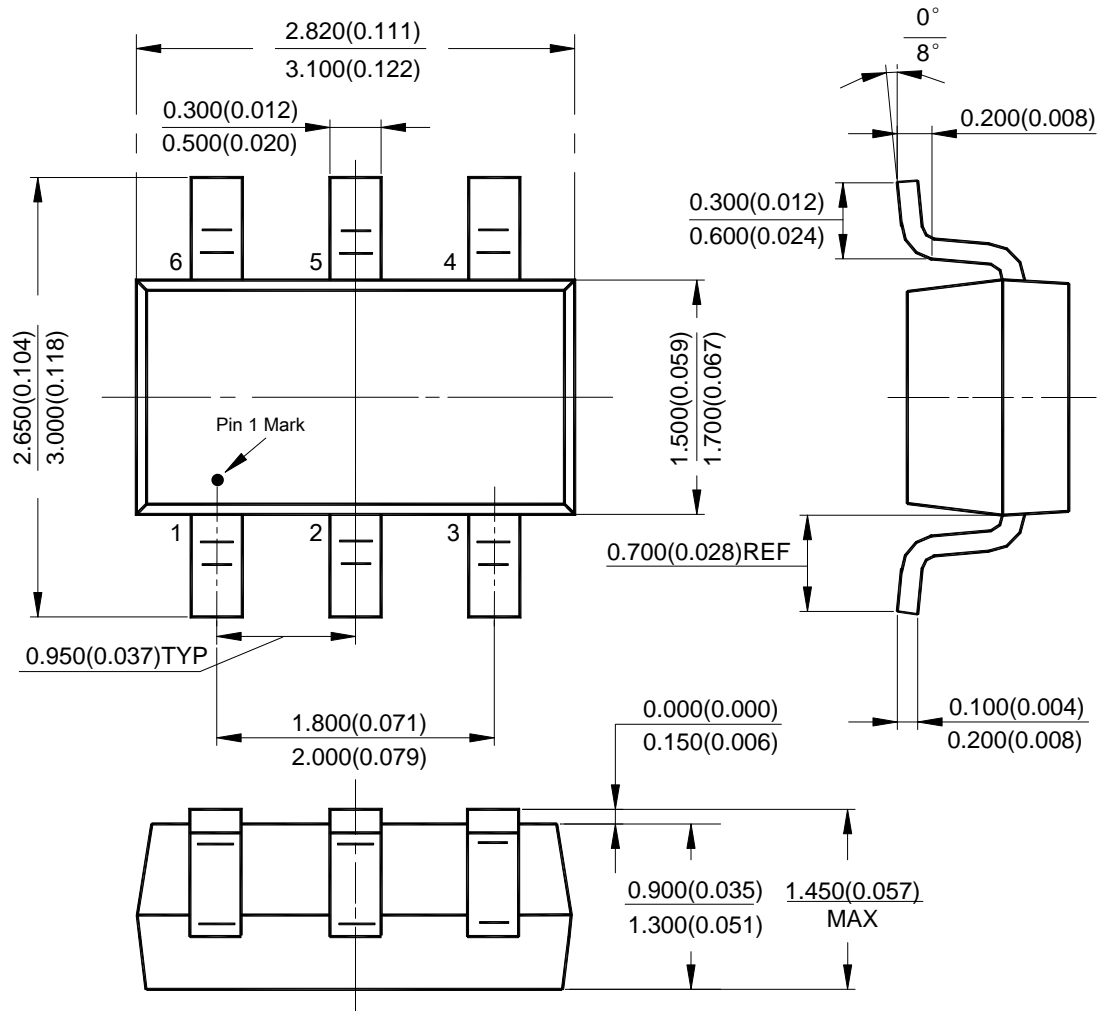

Suggested Pad Layout

(1) Package Type: SOT26

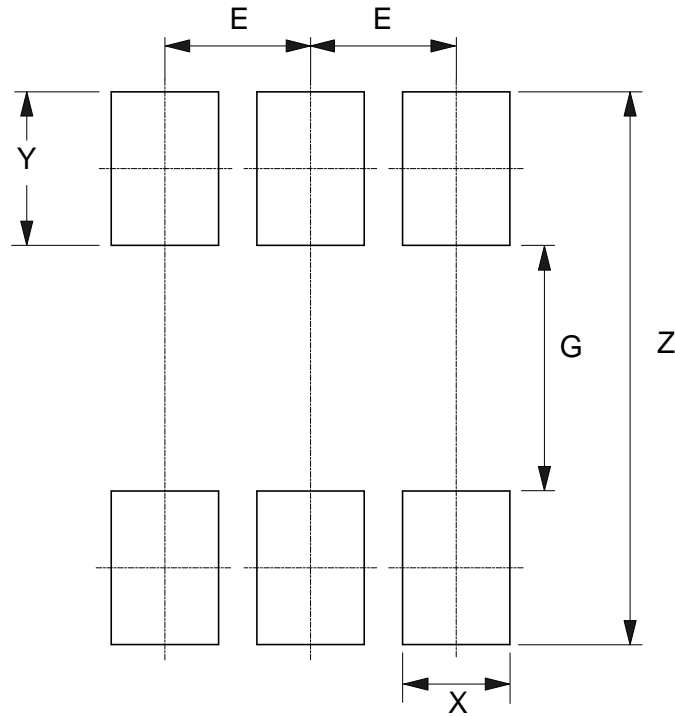

Dimensions	Z (mm)/(inch)	G (mm)/(inch)	X (mm)/(inch)	Y (mm)/(inch)	E (mm)/(inch)
Value	3.600/0.142	1.600/0.063	0.700/0.028	1.000/0.039	0.950/0.037