

## Description

The DIODES™ AP43771 is a highly integrated USB Type-C® power delivery controller and targeted for USB Type-C adapter and charger application. It is compatible with Qualcomm® QC4/QC4+ protocol, which supports USB power delivery specification Rev3.0 V1.2 (including optional PPS support).

The AP43771 can support PPS APDO (Augmented Power Data Object) with 20mV/step voltage resolution and 50mA/step current resolution for power management. What's more, cable-loss compensation and SOP command for e-Marker detection are embedded too.

The AP43771 can provide robust protection scheme with built-in OVP/OC/SCP/OTP features.

There are rich power functions embedded on the chip so as to reduce total BOM. A one-time-programmable ROM is provided for main firmware, and multi-time-programmable ROM is provided for user configuration data.

## Features

- Compatible with USB PD Rev3.0 V1.2
- USB-IF PD3.0/PPS Certified TID = 1090028
- Qualcomm QC4/4+ Protocol Certificated
- OTP (One-Time-Programmable) for Main Firmware
- MTP (Multi-Time-Programmable) for System Configuration
- Built-in Regulator for CV and CC Control
- Support SCP/OTP/OVP/UVP with Auto Restart
- Support Power Saving Mode
- External N-MOSFET Control for VBUS Power Delivery
- Support e-Marker Cable Detection
- Operating Voltage Range: 3.3V to 16V
- Fewest External Component Count
- TID (1090028) for USB PD 3.0 PPS Compliance Test
- **Totally Lead-Free & Fully RoHS Compliant (Notes 1 & 2)**
- **Halogen and Antimony Free. "Green" Device (Note 3)**
- **For automotive applications requiring specific change control (i.e. parts qualified to AEC-Q100/101/104/200, PPAP capable, and manufactured in IATF 16949 certified facilities), please [contact us](mailto:contact@diodes.com) or your local Diodes representative. <https://www.diodes.com/quality/product-definitions/>**

- Notes:
1. No purposely added lead. Fully EU Directive 2002/95/EC (RoHS), 2011/65/EU (RoHS 2) & 2015/863/EU (RoHS 3) compliant.
  2. See <https://www.diodes.com/quality/lead-free/> for more information about Diodes Incorporated's definitions of Halogen- and Antimony-free, "Green" and Lead-free.
  3. Halogen- and Antimony-free "Green" products are defined as those which contain <900ppm bromine, <900ppm chlorine (<1500ppm total Br + Cl) and <1000ppm antimony compounds.

*Qualcomm is a trademark of Qualcomm Incorporated, registered in the United States and other countries. USB Type-C and USB-C are registered trademarks of USB Implementers Forum.*

## Pin Assignments

W-DFN3030-14 (Type A1)

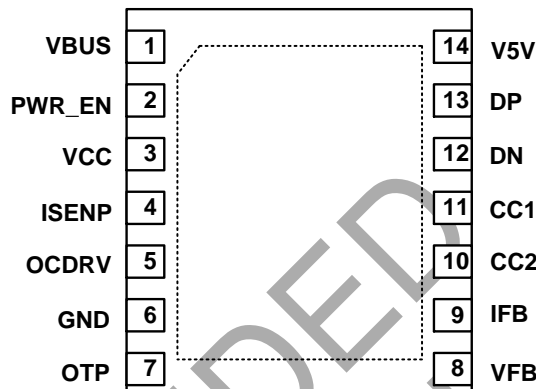

Top View

## Applications

- Type-C USB adapters/chargers
- USB PD converters

**Typical Applications Circuit**

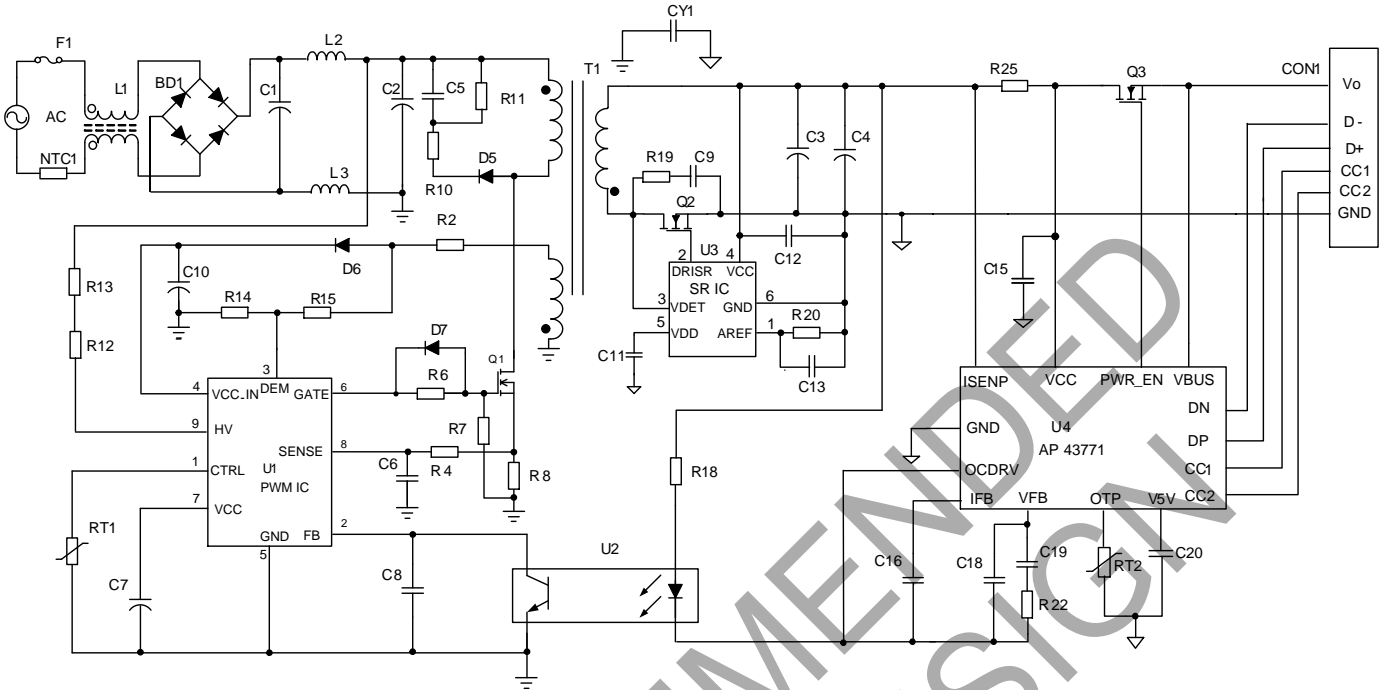

**Pin Descriptions**

Pin Number	Pin Name	Function
1	VBUS	Output Terminal for Discharge Path.
2	PWR_EN	External NMOS Gate Driver. To control External MOS switch, 1: To enable VBUS voltage 0: Disconnect VBUS.
3	VCC	The Power Supply of the IC, connected to a ceramic capacitor.
4	ISENP	Input Current Sense Positive Node.
5	OCDRV	CC/CV Output. Open Drain Output for Opto-Coupler.
6	GND	Ground
7	OTP	Source Current to External NTC Sensor for OTP (Over Temperature Protection). Current amplitude is programmable.
8	VFB	CV Input. Negative Node of CV OPAMP for Opto-Coupler.
9	IFB	CC Input. Negative Node of CC OPAMP for Opto-Coupler.
10	CC2	Type-C_CC2
11	CC1	Type-C_CC1
12	DN	Type-C_DN
13	DP	Type-C_DP
14	V5V	LDO-5V Output

**Functional Block Diagram**

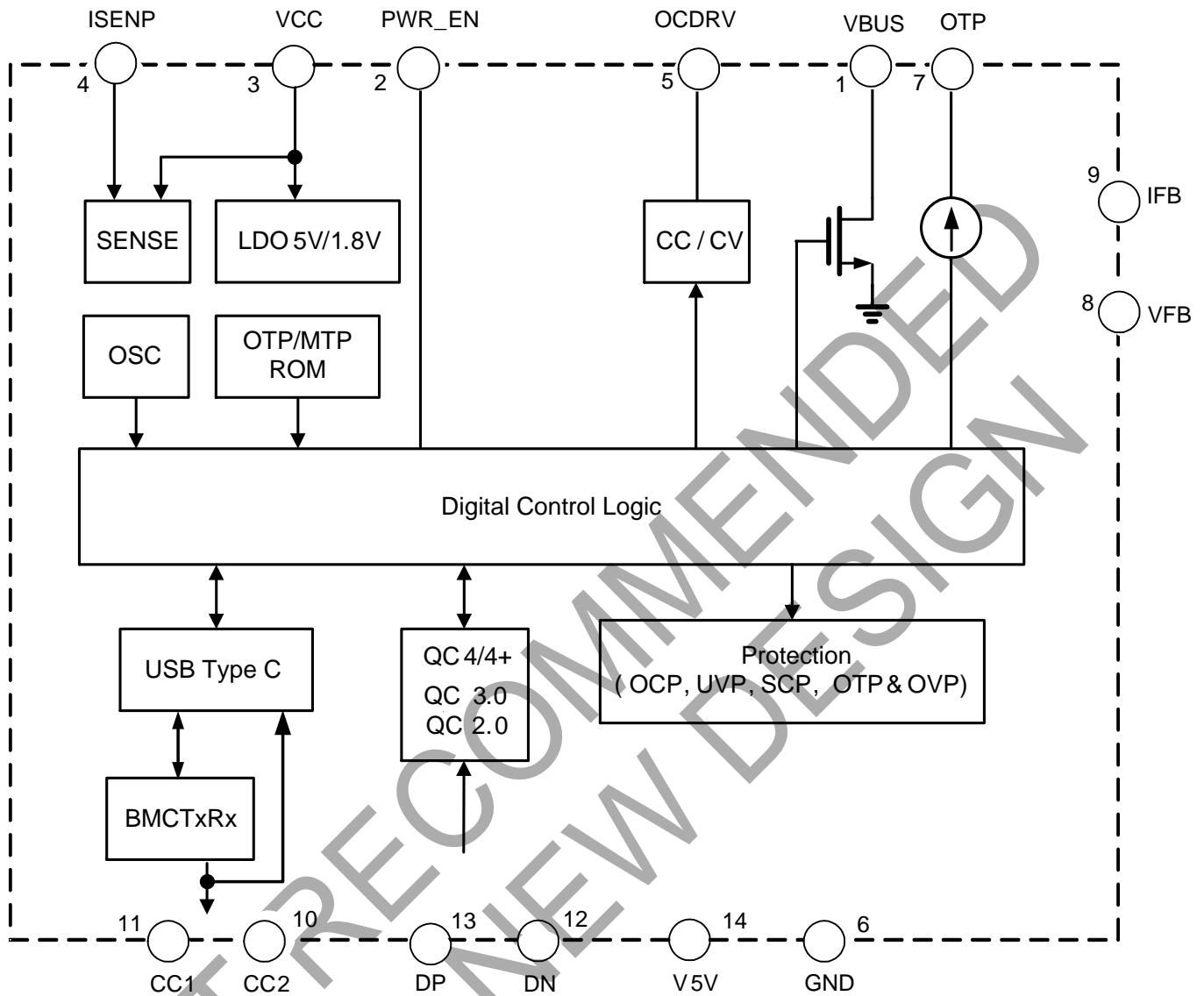

NOT RECOMMENDED FOR NEW DESIGN

### Absolute Maximum Ratings (Note 4)

Symbol	Parameter	Rating	Unit
V <sub>CC</sub>	Input Voltage at VCC Pin	-0.3 to 24	V
V <sub>F<sub>B</sub></sub> , V <sub>I<sub>F<sub>B</sub></sub></sub> , V <sub>O<sub>T<sub>P</sub></sub></sub>	Input Voltage at VFB, IFB, OTP Pins	-0.3 to 7	V
V <sub>B<sub>U<sub>S</sub></sub></sub> , V <sub>P<sub>W<sub>R</sub>_E<sub>N</sub></sub></sub> , V <sub>I<sub>S<sub>E<sub>N<sub>P</sub></sub></sub></sub>, V<sub>O<sub>C<sub>D<sub>R<sub>V</sub></sub></sub></sub></sub></sub>	Input Voltage at VBUS, PWR_EN, ISENP, OCDRV Pins	-0.3 to 24	V
—	Voltage from PWR_EN to VCC Pin	-16 to 7	V
V <sub>V<sub>5<sub>V</sub></sub></sub>	Input Voltage at V5V Pin	-0.3 to 7	V
V <sub>C<sub>C<sub>1</sub></sub></sub> , V <sub>C<sub>C<sub>2</sub></sub></sub>	Input Voltage at CC1, CC2 Pins	-0.3 to 7	V
V <sub>D<sub>P</sub></sub> , V <sub>D<sub>N</sub></sub>	Input Voltage at DP, DN Pins	-0.3 to 7	V
T <sub>J</sub>	Operating Junction Temperature	-40 to +150	°C
T <sub>S<sub>T<sub>G</sub></sub></sub>	Storage Temperature	-65 to +150	°C
T <sub>L<sub>E<sub>A<sub>D</sub></sub></sub></sub>	Lead Temperature (Soldering, 10s)	+300	°C
θ <sub>J<sub>A</sub></sub>	Thermal Resistance (Junction to Ambient) (Note 5)	122	°C/W
θ <sub>J<sub>C</sub></sub>	Thermal Resistance (Junction to Case) (Note 5)	27	°C/W
—	ESD (Human Body Model) Voltage on DP, DN Pins	8	kV
—	ESD (Human Body Model) Voltage on VBUS, ISENP, PWR_EN, VCC, OCDRV, OTP, V5V, IFB, VFB, CC1, CC2 Pins	2	kV
—	ESD (Charged Device Model)	750	V

Notes: 4. Stresses greater than those listed under *Absolute Maximum Ratings* can cause permanent damage to the device. These are stress ratings only, and functional operation of the device at these or any other conditions beyond those indicated under *Recommended Operating Conditions* is not implied. Exposure to *Absolute Maximum Ratings* for extended periods can affect device reliability.  
 5. Test condition: Device mounted on FR-4 substrate PC board, 2oz copper, with the minimum footprint.

### Recommended Operating Conditions

Symbol	Parameter	Min	Max	Unit
V <sub>CC</sub>	Power Supply Voltage	3.3	16	V
T <sub>O<sub>P</sub></sub>	Operating Temperature Range	-40	+85	°C

**Electrical Characteristics** (@T<sub>A</sub> = +25°C, unless otherwise specified.)

Symbol	Parameter	Condition	Min	Typ	Max	Unit
<b>VCC PIN SECTION</b>						
V <sub>ST</sub>	Startup Voltage	—	2.7	2.8	3.2	V
V <sub>UVLO</sub>	Minimum Operating Voltage	—	2.6	2.7	3	V
V <sub>CC_HYS</sub>	V <sub>CC</sub> Hysteresis (V <sub>ST</sub> -V <sub>UVLO</sub> )	—	0.1	—	—	V
I <sub>CC_DEEP SLEEP</sub>	V <sub>IN</sub> Current in Deep Sleep Mode	CC1/2 Detach after 3s	—	550	700	μA
I <sub>CC_OPR</sub>	Operating Supply Current	—	—	3.3	6	mA
<b>VOLTAGE CONTROL LOOP SECTION</b>						
V <sub>REF_CV5</sub>	Reference Voltage for 5V CV Control	—	0.49	0.5	0.51	V
V <sub>REF_CV9</sub>	Reference Voltage for 9V CV Control	—	0.88	0.90	0.92	V
V <sub>REF_CV12</sub>	Reference Voltage for 12V CV Control	—	1.17	1.20	1.23	V
V <sub>CABLE</sub>	Cable Compensation (Note 6)	—	24	30	36	mV/A
I <sub>OS</sub>	Maximum OCDRV Pin Sink Current	V <sub>OUT</sub> = 4V	10	16	30	mA
<b>PROTECTION FUNCTION SECTION</b>						
V <sub>OVP5V</sub>	OVP_5V Enable Voltage (Note 7)	—	5.5	6	6.5	V
V <sub>OVP9V</sub>	OVP_9V Enable Voltage (Note 7)	—	9.9	10.8	12.1	V
V <sub>OVP12V</sub>	OVP_12V Enable Voltage (Note 7)	—	13.2	14.4	16.2	V
t <sub>DEBOUNCE_OVP</sub>	OVP Debounce Time (Note 9)	—	—	90	—	ms
V <sub>UVP5V</sub>	UVP_5V Enable Voltage	—	3.4	3.8	4.2	V
V <sub>UVP9V</sub>	UVP_9V Enable Voltage	—	6.1	6.8	7.5	V
V <sub>UVP12V</sub>	UVP_12V Enable Voltage	—	8.2	9.1	10	V
I <sub>OVD</sub>	Over Voltage Discharge Current	—	—	240	—	mA
t <sub>OCP</sub>	OCP Deglitch Time (Note 8)	—	—	30	—	ms
t <sub>RESTART_INTERVAL_SCP</sub>	Restart Interval Time under SCP (Note 8)	—	—	0.8	—	s
T <sub>OTP</sub>	Internal OTP Temperature	—	—	+140	—	°C
I <sub>OTP_EXTERNAL</sub>	External OTP Current	—	—	100	—	μA

- Notes:
- Cable compensation voltage can be adjusted by setting from 0 to V<sub>CABLE</sub>·N, (N: 0 to 7).
  - 120% OVP setting.
  - Guaranteed by design.
  - OVP blanking time during V<sub>O</sub> transition from high output voltage to low output voltage, such as 9V to 5V, or 12V to 5V.

**Electrical Characteristics** (@T<sub>A</sub> = +25°C, unless otherwise specified.) (continued)

Symbol	Parameter	Condition	Min	Typ	Max	Unit
<b>PROTECTION FUNCTION SECTION</b>						
T <sub>HYS</sub>	OTP Recovery Hysteresis Temperature	—	—	+25	—	°C
t <sub>SLEEP</sub>	Enter Sleep Mode Time after Cable Detached (Note 8)	—	—	3	—	s
t <sub>OV_DELAY</sub>	Delay from OVP Threshold Trip to NMOS Gate Turn-Off (Note 8)	—	—	—	50	μs
t <sub>UV_DELAY</sub>	Delay from UVP Threshold Trip to NMOS Gate Turn-Off (Note 8)	—	—	30	—	ms
<b>CC1/CC2, DP/DN PIN SECTION</b>						
V <sub>L_RD3A</sub>	Low Voltage Threshold Used to Distinguish R <sub>D</sub> Attached or Detached for 3A Delivery	—	—	1.35	—	V
V <sub>H_RD3A</sub>	High Voltage Threshold Used to Distinguish R <sub>D</sub> Attached or Detached for 3A Delivery	—	—	2.0	—	V
I <sub>RD3A</sub>	CC1/CC2 Current Source for 3A Advertisement	—	304	330	356	μA
V <sub>OVP_DN</sub>	DN Line Over Voltage Protection Threshold	—	4.2	4.5	4.8	V
V <sub>OVP_DP</sub>	DP Line Over Voltage Protection Threshold	—	4.2	4.5	4.8	V

Note: 8. Guaranteed by design.

NOT RECOMMENDED FOR NEW DESIGN

---

## Performance Characteristics

---

### System Power-On Sequence:

When the external power source is provided, the AP43771 will wake up, and the USB PD controller and MCU will be initialized. All analog control blocks are ready and waiting for PD negotiation process. Meanwhile, the AP43771 monitors the voltage and current conditions to prevent abnormal conditions from happening. Once any unacceptable condition happens, the AP43771 will go into protection procedure according to the types of abnormal conditions.

### Voltage Transition

According to USB PD's protocol, the PD device requests different power profile and the AP43771's power control blocks will change voltage and current values. The AP43771 provides corresponding Over Voltage Protection (OVP), Over Current Protection (OCP) scheme, and feedback system stability to guarantee monotonic voltage transition and avoid violating USB PD electrical specification.

The AP43771 provides zero-mismatch voltage methodology that is more flexible for customer system design requirement. When UFP/DFP makes an acceptable power request deal, the AP43771 will change the VFB pin voltage according to the USB PD command. The voltage regulator control loop regulates the required  $V_{BUS}$  voltage according to  $V_{FB}$ . In addition, the shunt regulator is built in to minimize the total external components and cost.

### Protection

The AP43771 provides OVP/UVP/OCP/SCP/OTP functions and also support Constant Current (CC) function. All of the protection thresholds depend on the requested power profile, and provide the most reliable protection scheme.

The AP43771 provides OVP feature by turning off the power switch when  $V_{BUS}$  is higher than OVP enable voltage. Meanwhile, it provides internal discharge path to reduce the overvoltage duration, and terminates discharge current as soon as  $V_{BUS}$  reaches the target voltage. To prevent the  $V_{BUS}$  pin from working abnormally, the AP43771 provides UVP function whenever  $V_{BUS}$  drops to UVP enable voltage.

To ensure the safe operation of USB PD, the AP43771 provides programmable OCP function to make sure output current will not be higher than the allowed maximum current. Once OCP conditions happen, the AP43771 will shut down the USB PD system and send "Hard Reset" to the Upstream-Facing Port (UFP) device.

### CV/CC

The AP43771 supports Constant Voltage (CV) and Constant Current (CC) functions to control the output voltage and the output current by the control pin OCDRV. During the CV mode, the AP43771 operates in fixed PDO, and the output voltage will be regulated to the requested voltage if the output current is below the allowed maximum current. Once the sink device draws more than  $I_{OCP}$ , the over current protection will be triggered. When the CC mode function is enabled, the output voltage drops, and the source current is limited within 150mA whenever output current exceeds the allowed maximum current. When the output voltage drops below UVP, constant current limit turns off  $V_{BUS}$  and starts error recovery procedure. The AP43771 will reset if the voltage continues dropping to UVLO threshold.

**Ordering Information**

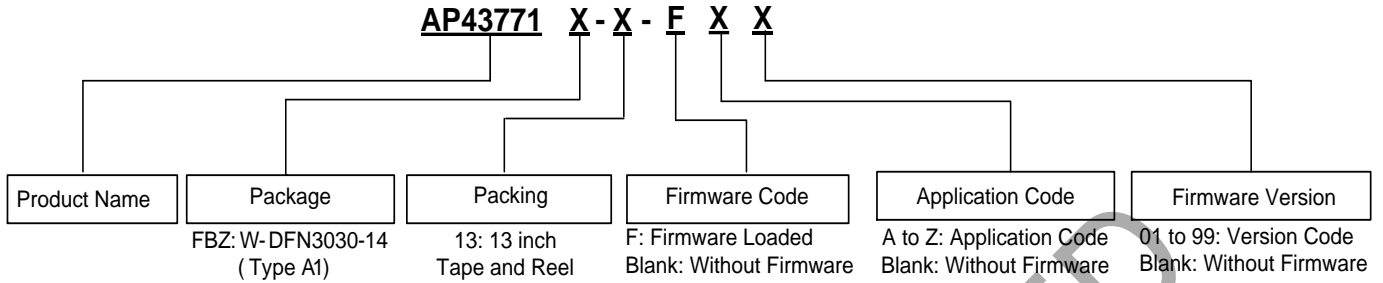

Part Number	Part Number Suffix	Package	Identification Code	Packing	
				Qty.	Carrier
AP43771FBZ-13-FXX	-13	W-DFN3030-14 (Type A1)	3V	3000	Tape and Reel

**Marking Information**

( Top View )

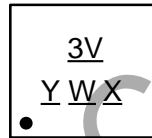

3V : Identification Code  
Y : Year : 0 to 9  
W : Week : A to Z : week 1 to 26;  
           a to z : week 27 to 52; z represents  
           week 52 and 53  
X : Internal Code

NOT RECOMMENDED FOR NEW DESIGN



**Package Outline Dimensions**

Please see <http://www.diodes.com/package-outlines.html> for the latest version.

W-DFN3030-14 (Type A1)

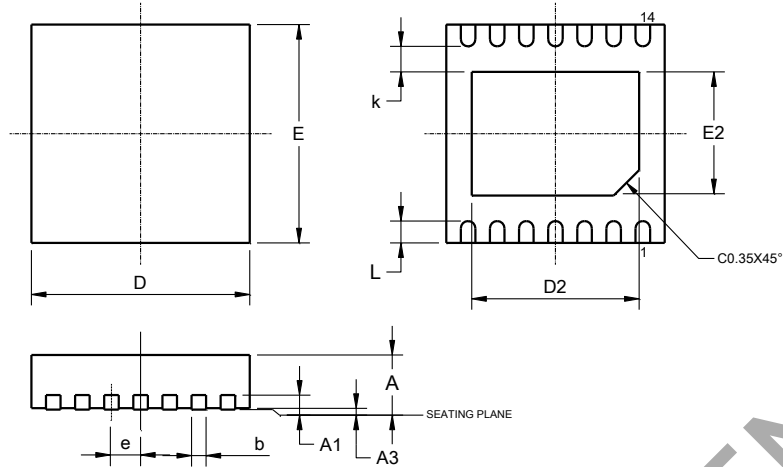

W-DFN3030-14 (Type A1)			
Dim	Min	Max	Typ
A	0.70	0.80	0.75
A1	0	0.05	0.02
A3	0.203REF		
b	0.15	0.25	0.20
D	3.00BSC		
D2	2.55	2.65	2.60
e	0.40BSC		
E	3.00BSC		
E2	1.65	1.75	1.70
k	0.20	--	--
L	0.35	0.45	0.40
All Dimensions in mm			

**Suggested Pad Layout**

Please see <http://www.diodes.com/package-outlines.html> for the latest version.

W-DFN3030-14 (Type A1)

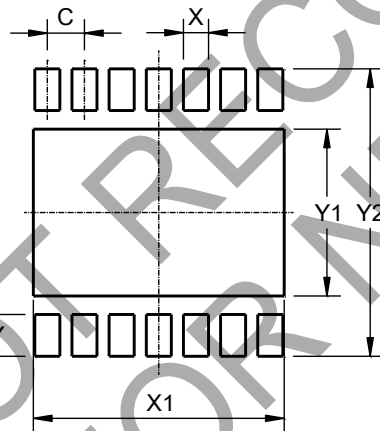

Dimensions	Value (in mm)
C	0.40
X	0.27
X1	2.70
Y	0.45
Y1	1.80
Y2	3.10