

# AP54RHC14

## Radiation Hardened Hex Inverter with cold sparing and Schmitt inputs

### 1 GENERAL DESCRIPTION

The AP54RHC14 is a radiation-hardened by design hex inverter with Schmitt inputs that is ideally suited for space, medical imaging and other applications demanding radiation tolerance and high reliability. It is fabricated in a 180 nm CMOS process utilizing proprietary radiation-hardening techniques, delivering high resiliency to single-event effects (SEE) and to a total ionizing dose (TID) up to 30 krad (Si).

This device is a member of the Apogee Semiconductor AP54RHC logic family operating across a voltage supply range of 1.65 V to 5.5 V.

The AP54RHC14 features true Schmitt triggers on each of its input buffers, providing hysteresis to accommodate slow-rising or noisy input signals without any input rise or fall time requirements.

Zero-power penalty™ cold-sparing is supported, along with Class 2 ESD protection on all inputs and outputs. A proprietary output stage and robust power-on reset (POR) circuit allow the AP54RHC14 to be cold-spared in any redundant configuration with no static power loss on any pad of the device. The redundant output stage also features a high drive capability with low static power loss.

The AP54RHC14 also features a triple-redundant design throughout its entire circuitry, which allows it to be immune to single-event transients (SET) without requiring additional redundant devices.

This device provides six instances of the Boolean logical function NOT ( $Y = \bar{A}$ ).

Ordering information may be found in Table 10 on Page 12.

### 1.1 FEATURES

- 1.65 VDC to 5.5 VDC operation
- Inputs tolerant up to 5.5 VDC at any  $V_{CC}$
- Schmitt triggers on inputs for slow rising signals
- Provides logic-level down translation to  $V_{CC}$
- Extended operating temperature range (-55 °C to +125 °C)
- Proprietary cold-sparing capability with zero static power penalty
- Built-in triple redundancy for enhanced reliability
- Internal power-on reset (POR) circuitry ensures reliable power up and power down responses during hot plug and cold sparing operations
- Class 2 ESD protection (4000 V HBM, 500 V CDM)
- TID resilience of 30 krad (Si)
- SEL resilient up to LET of 80 MeV-cm<sup>2</sup>/mg

### 1.2 LOGIC DIAGRAM

The AP54RHC14 logic function is shown below:

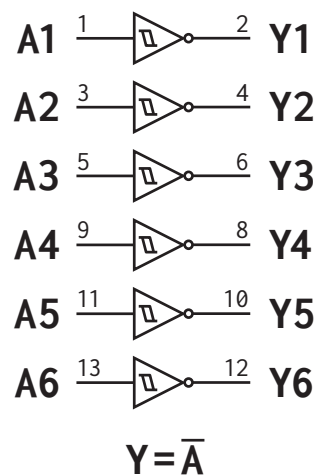

Figure 1: AP54RHC14 logic diagram



**CONTENTS**

<b>1</b>	<b>General Description</b>	<b>1</b>	5.5	Radiation Resilience . . . . .	8
1.1	Features . . . . .	1	5.6	Characteristics Measurement Information	8
1.2	Logic Diagram . . . . .	1	<b>6</b>	<b>Detailed Description</b>	<b>9</b>
<b>2</b>	<b>Acronyms and Abbreviations</b>	<b>2</b>	<b>7</b>	<b>Applications Information</b>	<b>10</b>
<b>3</b>	<b>Logic Data</b>	<b>3</b>	7.1	Use in Cold-Sparing Configuration . . . . .	10
3.1	Truth Table . . . . .	3	7.2	Power Supply Recommendations . . . . .	10
<b>4</b>	<b>Pin Configuration</b>	<b>3</b>	7.3	Application Tips . . . . .	10
<b>5</b>	<b>Electrical Characteristics</b>	<b>4</b>	<b>8</b>	<b>Packaging Information</b>	<b>11</b>
5.1	Absolute Maximum Ratings . . . . .	4	<b>9</b>	<b>Ordering Information</b>	<b>12</b>
5.2	Recommended Operating Conditions . . . . .	5	<b>10</b>	<b>Revision History</b>	<b>12</b>
5.3	Static Characteristics . . . . .	6	<b>11</b>	<b>Legal</b>	<b>13</b>
5.4	Dynamic Characteristics . . . . .	8			

**LIST OF TABLES**

1	Truth Table . . . . .	3	6	DC Electrical Characteristics . . . . .	6
2	Device Pinout . . . . .	3	7	DC Electrical Transfer Characteristics . . . . .	7
3	Absolute Maximum Ratings . . . . .	4	8	AC Electrical Characteristics . . . . .	8
4	Recommended Operating Conditions . . . . .	5	9	Radiation Resilience Characteristics . . . . .	8
5	Thermal Information . . . . .	5	10	Ordering Information . . . . .	12

**LIST OF FIGURES**

1	AP54RHC14 logic diagram . . . . .	1	6	Output Pin Structure . . . . .	9
2	Device Pinout . . . . .	3	7	Cold Spare Example . . . . .	10
3	Load Circuit . . . . .	8	8	Package Mechanical Drawing . . . . .	11
4	Propagation Delay . . . . .	8	9	Part Number Decoder . . . . .	12
5	Input Pin Structure . . . . .	9			

**2 ACRONYMS AND ABBREVIATIONS**

ESD	Electrostatic Discharge
POR	Power On Reset
RHA	Radiation Hardness Assurance
SEE	Single Event Effects
SEL	Single Event Latchup
SET	Single Event Transient
TID	Total Ionizing Dose
TMR	Triple Modular Redundancy
CDM	Charged-device Model
HBM	Human-body Model

### 3 LOGIC DATA

#### 3.1 TRUTH TABLE

The AP54RHC14 truth table is found in Table 1. **H** indicates HIGH logic level and **L** indicates LOW logic level. Subscript **n** reflects one of the six inverters in the device (1 to 6).

**Table 1:** AP54RHC14 device truth table

Input	Output
$A_n$	$Y_n$
L	H
H	L

### 4 PIN CONFIGURATION

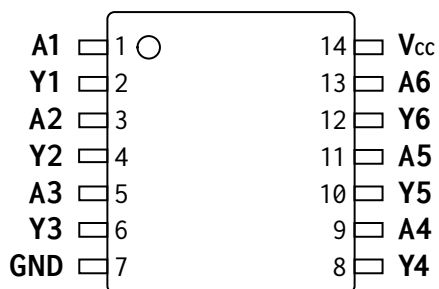

**Figure 2:** AP54RHC14 device pinout overview

**Table 2:** AP54RHC14 device pinout description

PIN NAME(S)	PIN NUMBER(S)	DESCRIPTION
A1	1	Logic Inputs
A2	3	
A3	5	
A4	9	
A5	11	
A6	13	
Y1	2	Logic Outputs
Y2	4	
Y3	6	
Y4	8	
Y5	10	
Y6	12	
V <sub>cc</sub>	14	Positive Voltage Supply
GND	7	Ground

## 5 ELECTRICAL CHARACTERISTICS

The sign convention for current follows JEDEC standards with negative values representing current sourced from the device and positive values representing current sunk into the device.

### 5.1 ABSOLUTE MAXIMUM RATINGS

Excursions beyond the values listed in Table 3 may cause permanent damage to the device. Proper function of the device cannot be guaranteed if these values are exceeded, and long-term device reliability may be affected. Functionality of the device at these values, or beyond those listed in [Recommended Operating Conditions](#) (Table 4) is not guaranteed.

All parameters are specified across the entire operating temperature range unless otherwise specified.

**Table 3:** Absolute Maximum Ratings

SYMBOL	PARAMETER	VALUE	UNITS	
$V_{CC}$	Supply Voltage	-0.5 to +5.5	V	
$V_I$	Input voltage range	-0.5 to +5.5	V	
$V_O$	Output voltage range	-0.5 to $V_{CC} + 0.5$ <sup>(1)</sup>	V	
$I_{IK} (V_I < 0)$	Input clamp current	100	mA	
$I_O$	Continuous output current (per pin)	100	mA	
$I_{CC}$	Maximum supply current	100	mA	
$V_{ESD}$	ESD Voltage	HBM	4000	V
		CDM	500	V
$T_J$	Operating junction temperature range	-55 to +150	°C	
$T_{STG}$	Storage temperature range	-65 to +150	°C	

<sup>(1)</sup>  $V_O$  must remain below absolute maximum rating of  $V_{CC}$

## 5.2 RECOMMENDED OPERATING CONDITIONS

All recommended parameters below are specified across the entire operating temperature range unless otherwise specified.

**Table 4:** Recommended Operating Conditions

SYMBOL	PARAMETER	MIN	MAX	UNITS	
$V_{CC}$	Supply voltage	1.65	5.5	V	
$V_I$	Input voltage range	0	5.5	V	
$V_O$	Output voltage range	0	$V_{CC}$	V	
$I_{OH}$	HIGH-level output current	$V_{CC} = 1.65$ to $1.95$ V	-	-4	mA
		$V_{CC} = 2.3$ to $2.7$ V	-	-8	
		$V_{CC} = 3.0$ to $3.6$ V	-	-16	
		$V_{CC} = 4.5$ to $5.5$ V	-	-24	
$I_{OL}$	LOW-level output current	$V_{CC} = 1.65$ to $1.95$ V	-	4	mA
		$V_{CC} = 2.3$ to $2.7$ V	-	8	
		$V_{CC} = 3.0$ to $3.6$ V	-	16	
		$V_{CC} = 4.5$ to $5.5$ V	-	24	

**Table 5:** Thermal Information

SYMBOL	PARAMETER	MIN	TYP	MAX	UNITS
$T_J$	Operating junction temperature	-55	-	+125	°C
$R_{\theta JA}$	Junction to ambient thermal resistance	-	100	-	°C/W

5.3 STATIC CHARACTERISTICS

All parameters are specified across the entire operating temperature range unless otherwise specified.

Table 6: DC Electrical Characteristics

SYMBOL	PARAMETER	CONDITIONS	V <sub>CC</sub>	MIN	TYP	MAX	UNITS
V <sub>OL</sub>	LOW-level output voltage	I <sub>O</sub> = 100 μA	1.65 to 5.5 V	-	0.02	0.05	V
		I <sub>O</sub> = 1 mA	1.65 to 5.5 V	-	0.05	0.1	V
		I <sub>O</sub> = 4 mA	2.3 V	-	0.3	0.6	V
			3.0 V	-	0.2	0.4	V
			4.5 V	-	0.2	0.4	V
		I <sub>O</sub> = 8 mA	2.3 V	-	0.6	1.0	V
			3.0 V	-	0.4	0.8	V
			4.5 V	-	0.3	0.6	V
		I <sub>O</sub> = 16 mA	3.0 V	-	1.0	1.4	V
			4.5 V	-	1.1	1.5	V
I <sub>O</sub> = 24 mA	4.5 V	-	1.1	1.5	V		
V <sub>OH</sub>	HIGH-level output voltage	I <sub>O</sub> = -100 μA	1.65 to 5.5 V	V <sub>CC</sub> - 0.1	V <sub>CC</sub> - 0.02	-	V
		I <sub>O</sub> = -1 mA	1.65 to 5.5 V	V <sub>CC</sub> - 0.15	V <sub>CC</sub> - 0.08	-	V
		I <sub>O</sub> = -4 mA	2.3 V	1.8	2.0	-	V
			3.0 V	2.6	2.8	-	V
			4.5 V	4.2	4.4	-	V
		I <sub>O</sub> = -8 mA	2.3 V	1.4	1.7	-	V
			3.0 V	2.2	2.5	-	V
			4.5 V	3.9	4.1	-	V
		I <sub>O</sub> = -16 mA	3.0 V	1.5	2.0	-	V
			4.5 V	3.3	3.8	-	V
I <sub>O</sub> = -24 mA	4.5 V	3.0	3.5	-	V		
I <sub>CC</sub>	Quiescent supply current	V <sub>I</sub> = V <sub>CC</sub> or GND I <sub>O</sub> = 0 mA	5.5 V	-	146	252	μA
I <sub>I</sub>	Input current	V <sub>I</sub> = V <sub>CC</sub> or GND	1.65 to 5.5 V	-	-	±1	μA
I <sub>OFF</sub>	Powerdown leakage current <sup>(1,3)</sup>	V <sub>I</sub> = V <sub>CC</sub> or GND	OFF <sup>(2)</sup>	-	-	5	μA

- (1) into any input or output port
- (2) V<sub>CC</sub> is disconnected or at GND potential
- (3) guaranteed by design

Table 7: DC Electrical Transfer Characteristics

SYMBOL	PARAMETER	CONDITIONS	V <sub>CC</sub>	MIN	TYP	MAX	UNITS
V <sub>T+</sub>	Positive-going threshold voltage		1.65 to 5.5 V	-			V
			1.65 to 5.5 V	-			V
			1.65 V	-			V
			2.3 V	-			V
			3.0 V	-			V
			4.5 V	-			V
			2.3 V	-			V
			3.0 V	-			V
			4.5 V	-			V
			3.0 V	-			V
			4.5 V	-			V
		4.5 V	3.05	-	3.15	V	
V <sub>T-</sub>	Negative-going threshold voltage	I <sub>0</sub> = 100 μA	1.65 to 5.5 V	-			V
			1.65 to 5.5 V	-			V
			1.65 V	-			V
			2.3 V	-			V
			3.0 V	-			V
			4.5 V	-			V
			2.3 V	-			V
			3.0 V	-			V
			4.5 V	-			V
			3.0 V	-			V
			4.5 V	-			V
		4.5 V	2.15	-	2.25	V	
ΔV <sub>T-</sub>	Input hysteresis (V <sub>T+</sub> - V <sub>T-</sub> )	I <sub>0</sub> = 100 μA	1.65 to 5.5 V	-			V
			1.65 to 5.5 V	-			V
			1.65 V	-			V
			2.3 V	-			V
			3.0 V	-			V
			4.5 V	-			V
			2.3 V	-			V
			3.0 V	-			V
			4.5 V	-			V
			3.0 V	-			V
			4.5 V	-			V
		4.5 V	0.9	-	1.1	V	

5.4 DYNAMIC CHARACTERISTICS

All parameters are specified across the entire operating temperature range unless otherwise specified.

Table 8: AC Electrical Characteristics

SYMBOL	PARAMETER	CONDITIONS	V <sub>CC</sub>	MIN	TYP	MAX	UNITS
t <sub>pd</sub> <sup>(1)</sup>	Propagation Delay (Input A <sub>n</sub> to Output Y <sub>n</sub> )	C <sub>L</sub> = 50 pF	4.5 to 5.5 V	-	7.6	11	ns
			3.0 to 3.6 V	-	9	13	ns
			2.3 to 2.7 V	-	11	15	ns
			1.65 to 1.95 V	-	17	25	ns
C <sub>IN</sub>	Input Capacitance <sup>(2)</sup>	V <sub>I</sub> = V <sub>CC</sub> or GND	1.65 to 5.5 V	-	2	4	pF
C <sub>PD</sub>	Power dissipation capacitance <sup>(2)</sup>	I <sub>O</sub> = 0 mA f = 1 MHz	5.5 V	-	40	-	pF

(1) equivalent to t<sub>PLH</sub>, t<sub>PHL</sub>

(2) guaranteed by design

5.5 RADIATION RESILIENCE

For detailed radiation testing reports, please contact Apogee Semiconductor at [sales@apogeesemi.com](mailto:sales@apogeesemi.com).

Table 9: Radiation Resilience Characteristics

PARAMETER	CONDITIONS	VALUE	UNITS
Total Ionizing Dose (TID)	Please contact Apogee Semiconductor for test report.	30	krad (Si)
SEE LET Threshold	Please contact Apogee Semiconductor for test report.	<80	MeV-cm <sup>2</sup> /mg

5.6 CHARACTERISTICS MEASUREMENT INFORMATION

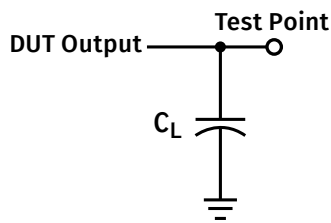

Figure 3: Load circuit for outputs

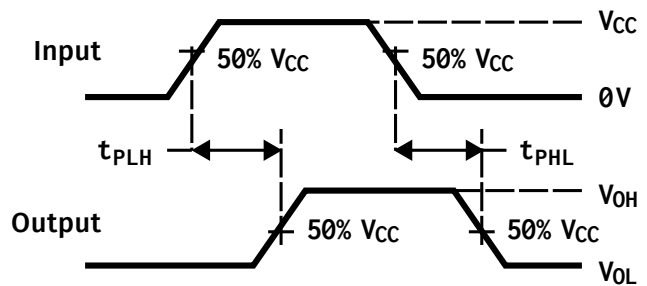

Figure 4: Propagation delay measurement



## 6 DETAILED DESCRIPTION

The AP54RHC14 is a hex inverter with Schmitt inputs intended to perform the Boolean function **NOT** ( $Y = \bar{A}$ ) in positive logic. Designed to operate from a wide supply voltage of 1.65 to 5.5 V, it has fully redundant input and output stages providing for superior resiliency to single event effects.

The output and input stages are constructed with transient activated clamps (Figure 5, 6) that prevent inadvertent biasing of the  $V_{CC}$  power rail through parasitic diodes inherent to conventional input, output, and ESD circuits. The IC also incorporates an internal power-on reset (POR) circuit that prevents the output from driving erroneous results during power-on, and guarantees correct operation at power supply voltages as low as 1.65 V. While the supply is ramping, the POR holds the output buffer in tri-state, a feature that prevents unwanted DC current during cold sparing on input and output pins.

The AP54RHC family's I/O protection circuitry allows for cold sparing configurations as it avoids a leakage current penalty on inputs and outputs while in a power-down state. This can result in considerable power savings in systems where multiple-path redundancy is employed. The ESD clamp circuits for this logic family are designed to support Class 2 ESD levels of 4 kV HBM and 500 V CDM.

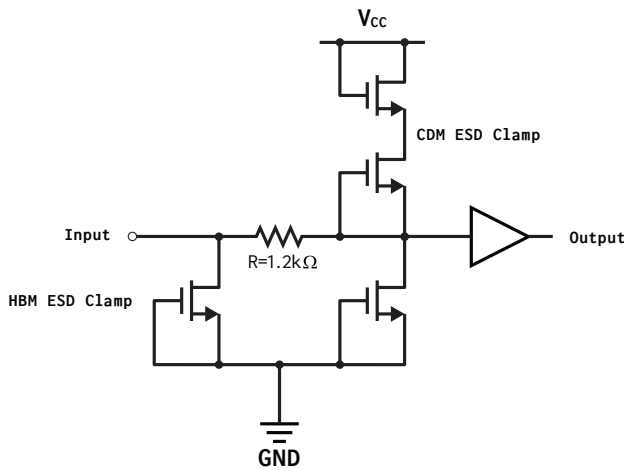

Figure 5: Details of input pin structure

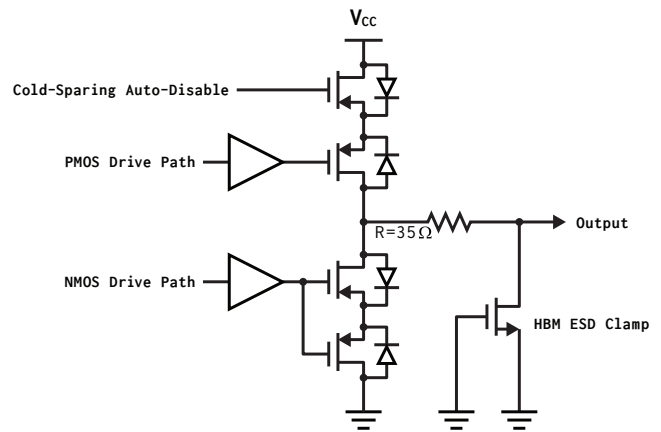

Figure 6: Details of output pin structure

## 7 APPLICATIONS INFORMATION

The Schmitt trigger operation of this gate allows for it to be used in applications where input signals with slow ramps or additive noise exist. Slow rising input signals into CMOS inputs may cause “shoot-through” to occur on conventional input gates, but is resolved by the Schmitt trigger operation of the AP54RHC14 and its input hysteresis that results in no input rise or fall time limitations. Additionally, the Schmitt trigger operation and level conversion offered by this IC will guarantee that gate outputs exhibit clean and fast transitions at the appropriate  $V_{CC}$  level(s).

### 7.1 USE IN COLD-SPARING CONFIGURATION

As the AP54RHC family is radiation-hardened by design and includes internal TMR, it can be utilized in high-reliability applications without additional supporting circuitry or devices. Nonetheless, some application requirements call for fully-redundant designs, where an “A” and a “B” device are required, often on separate power rails.

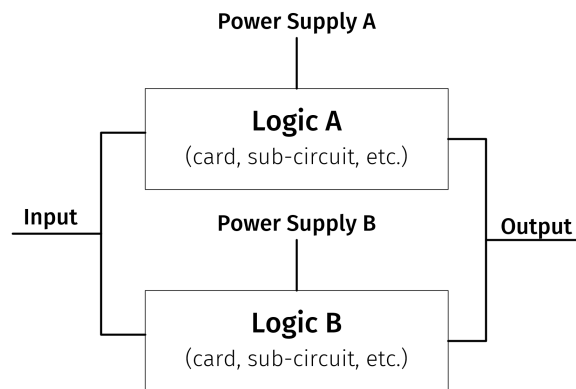

**Figure 7:** Two-path cold-sparing configuration.

With the cold-sparing capability of the AP54RHC family, fully redundant “A” and “B” functions may be placed in parallel (as seen in Figure 7) running off redundant power supplies. The inputs and outputs on each one of these functions are assumed to be based on the AP54RHC family, allowing for direct parallel connection without unwanted leakage current paths during cold sparing. In the event of a failure in power supply A or within function A, the system can simply shut power supply A off and switch on power supply B, without requiring additional input or output switching or configuration changes.

### 7.2 POWER SUPPLY RECOMMENDATIONS

This device can operate at any voltage within the range specified in [Table 4 Recommended Operating Conditions](#).

At a minimum, a 16 VDC (or higher), X7R-rated 0.1  $\mu\text{F}$  ceramic decoupling capacitor should be placed near (within 1 cm) the  $V_{CC}$  pin of the device.

### 7.3 APPLICATION TIPS

Unused **inputs** must **not** be left floating. They may be connected to either a low (GND) or high ( $V_{CC}$ ) bias to provide a known state at the input of the device. Resistors may be used to tie off unused inputs. In the event of a design change, such resistors can be removed, thereby allowing use of the inputs without having to cut traces on the PCB.

An unused **output** may be left floating. It is suggested that it be routed to a test point or similar accessible structure in case the gate needs to be utilized as part of a design revision.

8 PACKAGING INFORMATION

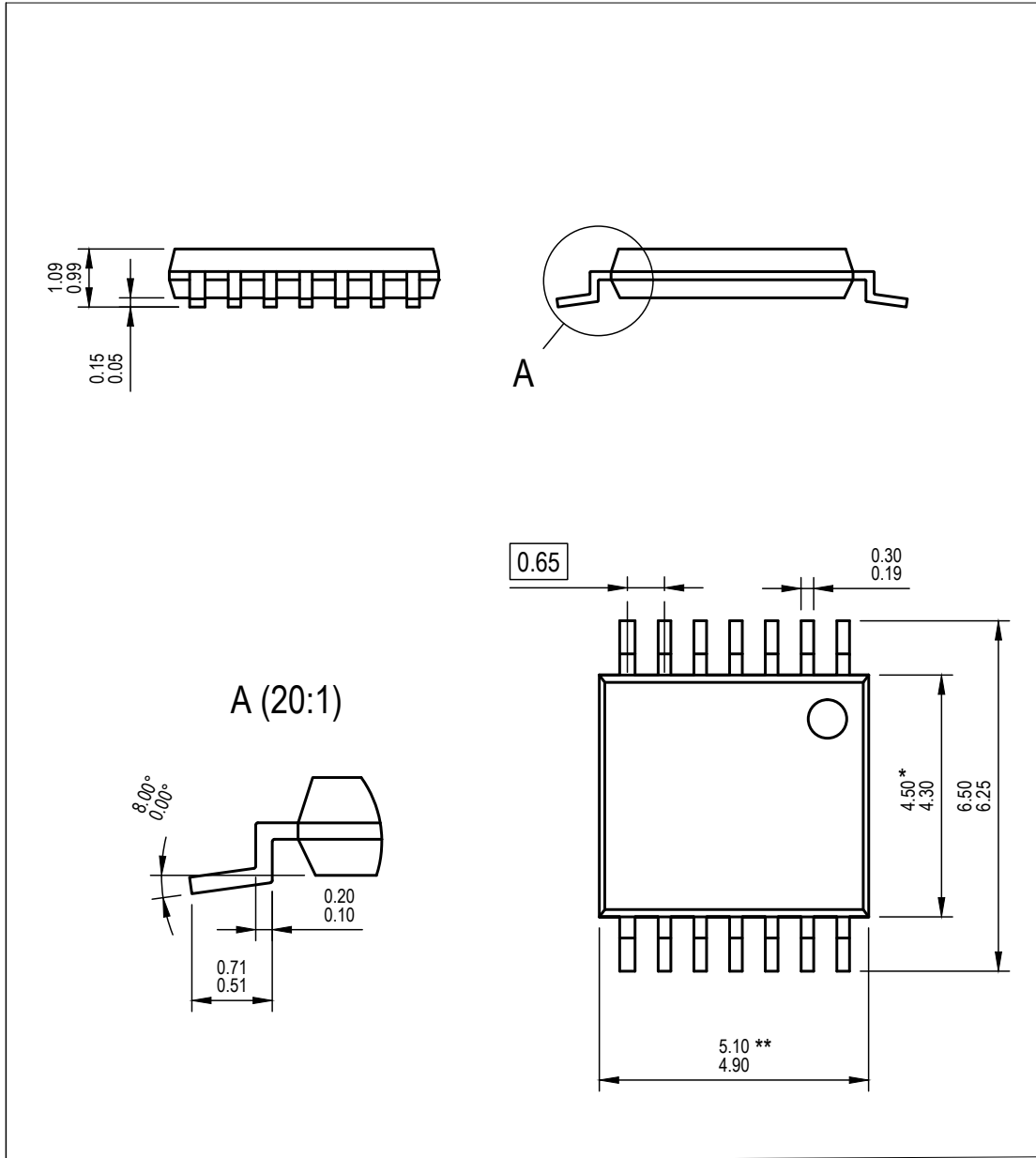

Notes:

1. All linear dimensions are in millimeters. Dimensioning and tolerancing are as per ISO/TS 128-71:2010
2. The part is compliant with JEDEC MO-153 specifications.

\* Body width does **not** include interlead flash. Interlead flash shall not exceed 0.25 mm each side.

\*\* Body length does **not** include mold flash, protrusion, or gate burrs. Mold flash, protrusions, and gate burrs shall not exceed 0.15 mm on each side.

Figure 8: Package Mechanical Detail

## 9 ORDERING INFORMATION

Example part numbers for the AP54RHC14 are listed in Table 10. The full list of options for this part can be found in Figure 9. Please contact Apogee Semiconductor sales at [sales@apogeesemi.com](mailto:sales@apogeesemi.com) for further information on sampling, lead time and purchasing on specific part numbers.

Table 10: AP54RHC14 Ordering Information

DEVICE	DESCRIPTION	PACKAGE
AP54RHC14ELT-W	Radiation Hardened Hex Inverter (for evaluation only)	Plastic TSSOP-14
AP54RHC14ALT-T	Radiation Hardened Hex Inverter (30 krad (Si))	Plastic TSSOP-14

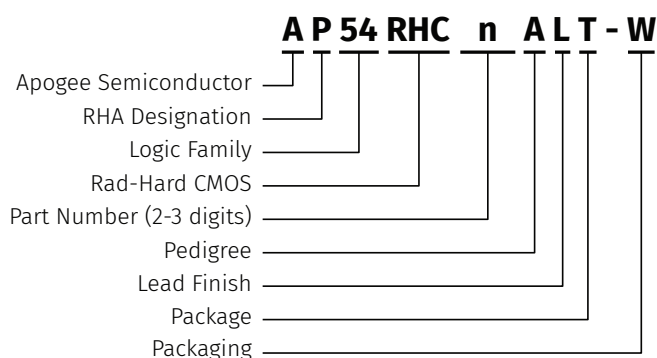

Figure 9: Part Number Decoder

- RHA Designation  
**P** 30 krad (Si)
- Part Number  
**14** (Hex Inverter with Schmitt inputs)
- Pedigree  
**A** -55 to +125 °C (Burn-in)  
**B** -55 to +125 °C (No burn-in)  
**E** 25 °C Functional Test Only (Evaluation)
- Lead Finish  
**L** Tin-Lead (SnPb)  
**T** Matte Tin (Sn)
- Package  
**T** 14-pin Thin Shrink Small Outline Package (TSSOP)
- Packaging  
**W** Waffle Pack  
**J** JEDEC Tray  
**R** Tape and Reel  
**T** Tube

## 10 REVISION HISTORY

REVISION	DESCRIPTION	DATE
A03	Revamped static and dynamic characteristics with new test data.	2021-03-01
A02	Update Static and Dynamic characteristics.	2021-03-01
A01	Initial public release.	2020-02-29
A00	Initial internal release.	2019-07-05

For the latest version of this document, please visit <https://www.apogeesemi.com>.