

## Radiation Hardened 5-channel Level Translator with cold sparing and bus-keeper

### 1 GENERAL DESCRIPTION

The AP54RHC505 is a radiation-hardened by design 5-channel level translator with 3-state outputs and bus-keepers that is ideally suited for space, medical imaging and other applications demanding radiation tolerance and high reliability. It is fabricated in a 180 nm CMOS process utilizing proprietary radiation-hardening techniques, delivering high resiliency to single-event effects (SEE) and to a total ionizing dose (TID) up to 30 krad (Si).

This device is a member of the Apogee Semiconductor AP54RHC logic family. All members of this family operate across a full 1.65 V to 5.5 V range providing the system designer flexibility in logic-level interfaces. The AP54RHC505 can operate across this range on both of its supply voltage inputs, V<sub>CC</sub>A and V<sub>CC</sub>Y.

An output enable control pin allows the outputs to be placed in a high impedance (high-Z) state, simplifying usage in applications with shared busses or mixed power domains. Additionally, the outputs are placed in high-Z when V<sub>CC</sub>A is not present, ensuring that no loading or leakage paths are experienced at the output nodes when the input rail is not powered.

Zero-power penalty™ cold-sparing is supported, along with Class 2 ESD protection on all inputs and outputs. A proprietary output stage and robust power-on reset (POR) circuit allow the AP54RHC505 to be cold-spared in any redundant configuration with no static power loss on any pad of the device. The redundant output stage also features a high drive capability with low static power loss.

The AP54RHC505 also features a triple-redundant design throughout its entire circuitry, which allows it to be immune to single-event transients (SET) without requiring additional redundant devices.

Ordering information may be found in Table 9 on Page 13.

### 1.1 FEATURES

- 1.65 VDC to 5.5 VDC operation
- Inputs tolerant up to 5.5 VDC at any V<sub>CC</sub>A or V<sub>CC</sub>Y
- Latching of input state (**bus-keeper**) allows inputs to be left floating
- Extended operating temperature range (-55 °C to +125 °C)
- Proprietary **cold-sparing capability** with zero static power penalty
- **Built-in triple redundancy** for enhanced reliability
- Internal power-on reset (POR) circuitry ensures reliable power up and power down responses during hot plug and cold sparing operations
- Tri-state output drivers
- Class 2 ESD protection (4000 V HBM, 500 V CDM)
- TID resilience of **30 krad (Si)**
- SEL resilient up to LET of **80 MeV-cm<sup>2</sup>/mg**

### 1.2 LOGIC DIAGRAM

The AP54RHC505 logic function is shown below:

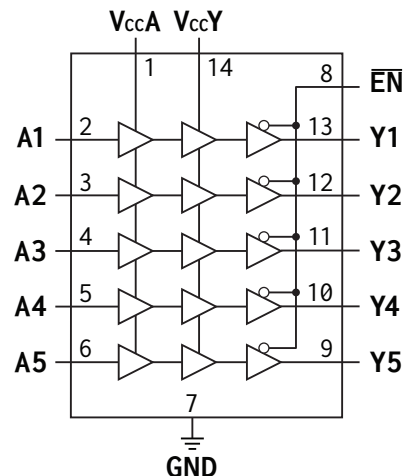

Figure 1: AP54RHC505 logic diagram

## CONTENTS

<b>1</b>	<b>General Description</b>	<b>1</b>	<b>5.6</b>	Characteristics Measurement Information	<b>8</b>
1.1	Features	1	<b>6</b>	<b>Detailed Description</b>	<b>9</b>
1.2	Logic Diagram	1	<b>7</b>	<b>Applications Information</b>	<b>10</b>
<b>2</b>	<b>Acronyms and Abbreviations</b>	<b>2</b>	7.1	Applications Example	10
<b>3</b>	<b>Logic Data</b>	<b>3</b>	7.2	Power Supply Recommendations	11
<b>4</b>	<b>Pin Configuration</b>	<b>3</b>	7.3	Application Tips	11
<b>5</b>	<b>Electrical Characteristics</b>	<b>4</b>	<b>8</b>	<b>Packaging Information</b>	<b>12</b>
5.1	Absolute Maximum Ratings	4	<b>9</b>	<b>Ordering Information</b>	<b>13</b>
5.2	Recommended Operating Conditions	5	<b>10</b>	<b>Revision History</b>	<b>13</b>
5.3	Static Characteristics	6	<b>11</b>	<b>Legal</b>	<b>14</b>
5.4	Dynamic Characteristics	7			
5.5	Radiation Resilience	7			

## LIST OF TABLES

1	Truth Table	3	6	DC Electrical Characteristics	6
2	Device Pinout	3	7	AC Electrical Characteristics	7
3	Absolute Maximum Ratings	4	8	Radiation Resilience Characteristics	7
4	Recommended Operating Conditions	5	9	Ordering Information	13
5	Thermal Information	5			

## LIST OF FIGURES

1	AP54RHC505 logic diagram	1	6	Input Pin Structure	9
2	Device Pinout	3	7	Output Pin Structure	9
3	Load Circuit	8	8	Cold Spare Example	10
4	Propagation Delay	8	9	Package Mechanical Drawing	12
5	Enable and Disable Timing	8	10	Part Number Decoder	13

## 2 ACRONYMS AND ABBREVIATIONS

ESD	Electrostatic Discharge
POR	Power On Reset
RHA	Radiation Hardness Assurance
SEE	Single Event Effects
SEL	Single Event Latchup
SET	Single Event Transient
TID	Total Ionizing Dose
TMR	Triple Modular Redundancy
CDM	Charged-device Model
HBM	Human-body Model

### 3 LOGIC DATA

The AP54RHC505 truth table is found in Table 1. **H** indicates HIGH logic level, **L** indicates LOW logic level, **X** indicates DON'T CARE and **Z** indicates HIGH-Z (TRI-STATE). Subscript **n** reflects one of the five buffers in the device (1 to 5).  $V_{CCA}$  is unpowered when disconnected or shorted to GND.

**Table 1:** AP54RHC505 device truth table

Supply	Inputs		Output
$V_{CCA}$	$\overline{EN}$	$A_n$	$Y_n$
Unpowered	X	X	Z
Powered	H	X	Z
Powered	L	L	L
Powered	L	H	H

### 4 PIN CONFIGURATION

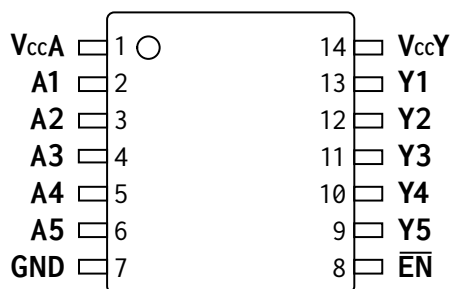

**Figure 2:** AP54RHC505 device pinout overview

**Table 2:** AP54RHC505 device pinout description

PIN NAME(S)	PIN NUMBER(S)	DESCRIPTION
A1	2	Inputs
A2	3	
A3	4	
A4	5	
A5	6	
Y1	13	3-State Outputs
Y2	12	
Y3	11	
Y4	10	
Y5	9	
$\overline{EN}$	8	Output Enable (active-low)
$V_{CCA}$	1	Positive Voltage Supply (A Side)
$V_{CCY}$	14	Positive Voltage Supply (Y Side)
GND	7	Ground

## 5 ELECTRICAL CHARACTERISTICS

The sign convention for current follows JEDEC standards with negative values representing current sourced from the device and positive values representing current sunk into the device.

### 5.1 ABSOLUTE MAXIMUM RATINGS

Excursions beyond the values listed in Table 3 may cause permanent damage to the device. Proper function of the device cannot be guaranteed if these values are exceeded, and long-term device reliability may be affected. Functionality of the device at these values, or beyond those listed in [Recommended Operating Conditions](#) (Table 4) is not guaranteed.

All parameters are specified across the entire operating temperature range unless otherwise specified.

**Table 3:** Absolute Maximum Ratings

SYMBOL	PARAMETER	VALUE	UNITS	
$V_{CCA}, V_{CCY}$	Supply Voltage	-0.5 to +5.5	V	
$V_I$	Input voltage range	-0.5 to +5.5	V	
$V_O$	Output voltage range	-0.5 to $V_{CC} + 0.5$ <sup>(1)</sup>	V	
$I_{IK} (V_I < 0)$	Input clamp current	100	mA	
$I_O$	Continuous output current (per pin)	100	mA	
$I_{CC}$	Maximum supply current	100	mA	
$V_{ESD}$	ESD Voltage	HBM	4000	V
		CDM	500	V
$T_J$	Operating junction temperature range	-55 to +150	°C	
$T_{STG}$	Storage temperature range	-65 to +150	°C	

<sup>(1)</sup>  $V_O$  must remain below absolute maximum rating of  $V_{CCA}, V_{CCY}$

## 5.2 RECOMMENDED OPERATING CONDITIONS

All recommended parameters below are specified across the entire operating temperature range unless otherwise specified.

**Table 4:** Recommended Operating Conditions

SYMBOL	PARAMETER	MIN	MAX	UNITS	
$V_{CCA}, V_{CCY}$	Supply voltage	1.65	5.5	V	
$V_I$	Input voltage range	0	5.5	V	
$V_O$	Output voltage range	0	$V_{CCY}$	V	
$V_{IH}$	HIGH-level input voltage	$V_{CCA} = 1.65$ to $1.95$ V	1.4	-	V
		$V_{CCA} = 2.3$ to $2.7$ V	1.9	-	
		$V_{CCA} = 3.0$ to $3.6$ V	2.5	-	
		$V_{CCA} = 4.5$ to $5.5$ V	3.8	-	
$V_{IL}$	LOW-level input voltage	$V_{CCY} = 1.65$ to $1.95$ V	-	0.4	V
		$V_{CCY} = 2.3$ to $2.7$ V	-	0.6	
		$V_{CCY} = 3.0$ to $3.6$ V	-	0.9	
		$V_{CCY} = 4.5$ to $5.5$ V	-	1.35	
$I_{OH}$	HIGH-level output current	$V_{CCY} = 1.65$ to $1.95$ V	-	-4	mA
		$V_{CCY} = 2.3$ to $2.7$ V	-	-8	
		$V_{CCY} = 3.0$ to $3.6$ V	-	-16	
		$V_{CCY} = 4.5$ to $5.5$ V	-	-24	
$I_{OL}$	LOW-level output current	$V_{CCY} = 1.65$ to $1.95$ V	-	4	mA
		$V_{CCY} = 2.3$ to $2.7$ V	-	8	
		$V_{CCY} = 3.0$ to $3.6$ V	-	16	
		$V_{CCY} = 4.5$ to $5.5$ V	-	24	
$t_r, t_f$	Input rise or fall time (10% - 90%)	$V_{CCA} = 1.65$ to $1.95$ V	-	1000	ns
		$V_{CCA} = 2.3$ to $2.7$ V	-	600	
		$V_{CCA} = 3.0$ to $3.6$ V	-	500	
		$V_{CCA} = 4.5$ to $5.5$ V	-	400	

**Table 5:** Thermal Information

SYMBOL	PARAMETER	MIN	TYP	MAX	UNITS
$T_J$	Operating junction temperature	-55	-	+125	°C
$R_{\theta JA}$	Junction to ambient thermal resistance	-	100	-	°C/W

### 5.3 STATIC CHARACTERISTICS

All parameters are specified across the entire operating temperature range unless otherwise specified.

**Table 6:** DC Electrical Characteristics

SYMBOL	PARAMETER	CONDITIONS	V <sub>CCY</sub>	MIN	TYP	MAX	UNITS
V <sub>OL</sub>	LOW-level output voltage <sup>(1)</sup>	I <sub>O</sub> = 100 μA	1.65 to 5.5 V	-	0.02	0.05	V
		I <sub>O</sub> = 1 mA	1.65 to 5.5 V	-	0.05	0.1	V
		I <sub>O</sub> = 4 mA	1.65 V	-	0.4	0.8	V
			2.3 V	-	0.3	0.6	V
			3.0 V	-	0.2	0.4	V
			4.5 V	-	0.2	0.4	V
		I <sub>O</sub> = 8 mA	2.3 V	-	0.6	1.0	V
			3.0 V	-	0.4	0.8	V
			4.5 V	-	0.3	0.6	V
		I <sub>O</sub> = 16 mA	3.0 V	-	1.0	1.4	V
4.5 V	-		1.1	1.5	V		
I <sub>O</sub> = 24 mA	4.5 V	-	1.1	1.5	V		
V <sub>OH</sub>	HIGH-level output voltage <sup>(1)</sup>	I <sub>O</sub> = -100 μA	1.65 to 5.5 V	V <sub>CCY</sub> - 0.1	V <sub>CCY</sub> - 0.02	-	V
		I <sub>O</sub> = -1 mA	1.65 to 5.5 V	V <sub>CCY</sub> - 0.15	V <sub>CCY</sub> - 0.08	-	V
		I <sub>O</sub> = -4 mA	2.3 V	1.8	2.0	-	V
			2.3 V	1.8	2.0	-	V
			3.0 V	2.6	2.8	-	V
			4.5 V	4.2	4.4	-	V
		I <sub>O</sub> = -8 mA	2.3 V	1.4	1.7	-	V
			3.0 V	2.2	2.5	-	V
			4.5 V	3.9	4.1	-	V
		I <sub>O</sub> = -16 mA	3.0 V	1.5	2.0	-	V
			4.5 V	3.3	3.8	-	V
		I <sub>O</sub> = -24 mA	4.5 V	3.0	3.5	-	V
		I <sub>CCY</sub>	Quiescent supply current	V <sub>I</sub> = GND, $\overline{EN}$ = "0" I <sub>O</sub> = 0 mA	5.5 V	-	100
SYMBOL	PARAMETER	CONDITIONS	V <sub>CCA</sub>	MIN	TYP	MAX	UNITS
I <sub>I</sub>	Input current	V <sub>I</sub> = V <sub>CC</sub> or GND	1.65 to 5.5 V	-	-	±1	μA
I <sub>OZ</sub>	Output leakage current <sup>(2)</sup>	V <sub>I</sub> = V <sub>CC</sub> or GND $\overline{EN}$ = "1"	1.65 to 5.5 V	-	-	±2.5	μA
I <sub>OFF</sub>	Powerdown leakage current <sup>(2,3)</sup>	V <sub>I</sub> = V <sub>CC</sub> or GND	0 to 5.5 V	-	-	5	μA
I <sub>CCA</sub>	Quiescent supply current	V <sub>I</sub> = V <sub>CC</sub> or GND I <sub>O</sub> = 0 mA	5.5 V	-	13	18	μA

(1) V<sub>CCA</sub> = 1.65 to 5.5 V for these conditions

(2) V<sub>CCY</sub> = 0 to 5.5 V for these conditions

(3) V<sub>CC</sub> is disconnected or at GND potential

## 5.4 DYNAMIC CHARACTERISTICS

All parameters are specified across the entire operating temperature range unless otherwise specified.

**Table 7:** AC Electrical Characteristics

SYMBOL	PARAMETER	CONDITIONS	V <sub>CCY</sub>	MIN	TYP	MAX	UNITS
<b>t<sub>pd</sub></b> <sup>(1)</sup>	Propagation Delay (Input <b>A</b> to Output <b>Y</b> )	C <sub>L</sub> = 50 pF	4.5 to 5.5 V	-	7.6	11	ns
			3.0 to 3.6 V	-	9	13	ns
			2.3 to 2.7 V	-	11	15	ns
			1.65 to 1.95 V	-	17	25	ns
<b>t<sub>en</sub></b> <sup>(2)</sup>	Output Enable Time (Input <b>EN</b> to Output <b>Y</b> )	C <sub>L</sub> = 50 pF	4.5 to 5.5 V	-	15	25	ns
			3.0 to 3.6 V	-	22	35	ns
			2.3 to 2.7 V	-	29	41	ns
			1.65 to 1.95 V	-	43	53	ns
<b>t<sub>dis</sub></b> <sup>(3)</sup>	Output Disable Time (Input <b>EN</b> to Output <b>Y</b> )	C <sub>L</sub> = 50 pF	4.5 to 5.5 V	-	16	25	ns
			3.0 to 3.6 V	-	22	35	ns
			2.3 to 2.7 V	-	28	40	ns
			1.65 to 1.95 V	-	42	51	ns
<b>t<sub>sk</sub></b>	Channel-to-channel skew	C <sub>L</sub> = 50 pF	1.65 to 5.5 V	-	-	1	ns
<b>C<sub>IN</sub></b>	Input Capacitance <sup>(4)</sup>	V <sub>I</sub> = V <sub>CC</sub> or GND	1.65 to 5.5 V	-	2	4	pF
<b>C<sub>PD</sub></b>	Power dissipation capacitance <sup>(4)</sup>	I <sub>O</sub> = 0 mA, f = 1 MHz	5.5 V	-	40	-	pF

- (1) equivalent to t<sub>PLH</sub>, t<sub>PHL</sub>
- (2) equivalent to t<sub>PZL</sub>, t<sub>PHL</sub>
- (3) equivalent to t<sub>PLZ</sub>, t<sub>PHZ</sub>
- (4) guaranteed by design

## 5.5 RADIATION RESILIENCE

For detailed radiation testing reports, please contact Apogee Semiconductor at [sales@apogeesemi.com](mailto:sales@apogeesemi.com).

**Table 8:** Radiation Resilience Characteristics

PARAMETER	CONDITIONS	VALUE	UNITS
Total Ionizing Dose (TID)	Please contact Apogee Semiconductor for test report.	30	krad (Si)
SEE LET Threshold	Please contact Apogee Semiconductor for test report.	<80	MeV-cm <sup>2</sup> /mg

5.6 CHARACTERISTICS MEASUREMENT INFORMATION

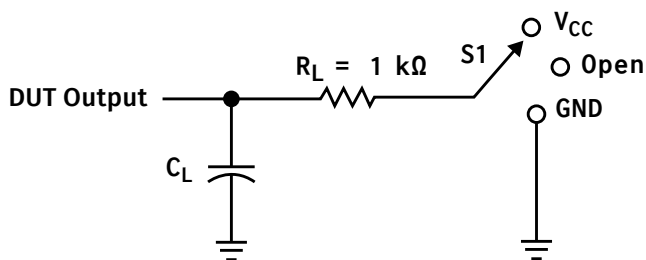

TEST	S1
$t_{pd}$	Open
$t_{PLZ}, t_{PZL}$	$V_{CC}$
$t_{PHZ}, t_{PZH}$	GND

Figure 3: Load circuit for 3-state outputs

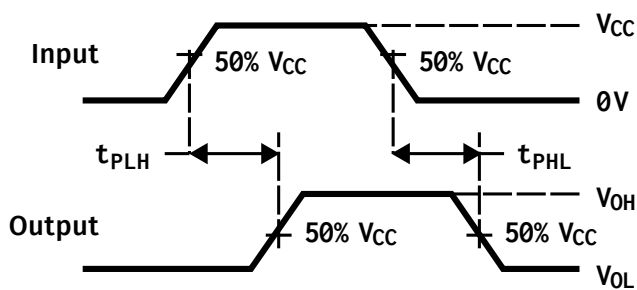

Figure 4: Propagation delay measurement

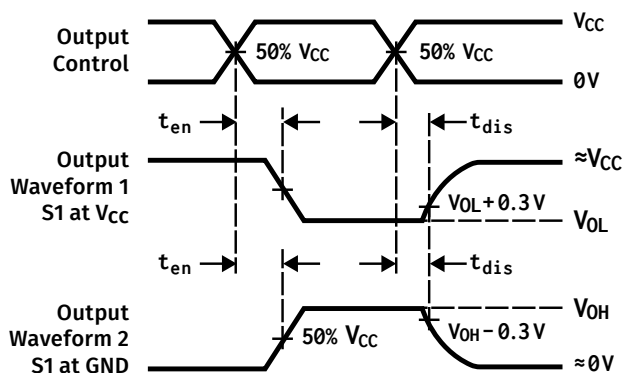

Figure 5: Enable and disable times, for low- and high-level enables



## 6 DETAILED DESCRIPTION

The AP54RHC505 is a 5-channel level translator with 3-state outputs and bus-keepers designed to operate from a wide supply voltage of 1.65 to 5.5 V with fully redundant input and output stages, providing for superior radiation resilience.

The output and input stages are constructed with transient activated clamps (Figure 6, 7) that prevent inadvertent biasing of the  $V_{CC}$  power rail through parasitic diodes inherent to conventional input, output, and ESD circuits. The IC also incorporates an internal power-on reset (POR) circuit that prevents the output from driving erroneous results during power-on, and guarantees correct operation at power supply voltages as low as 1.65 V. While the supply is ramping, the POR holds the output buffer in tri-state, a feature that prevents unwanted DC current during cold sparing on input and output pins.

The AP54RHC family's I/O protection circuitry allows for cold sparing configurations as it avoids a leakage current penalty on inputs and outputs while in a power-down state. This can result in considerable power savings in systems where multiple-path redundancy is employed. The ESD clamp circuits for this logic family are designed to support Class 2 ESD levels of 4 kV HBM and 500 V CDM.

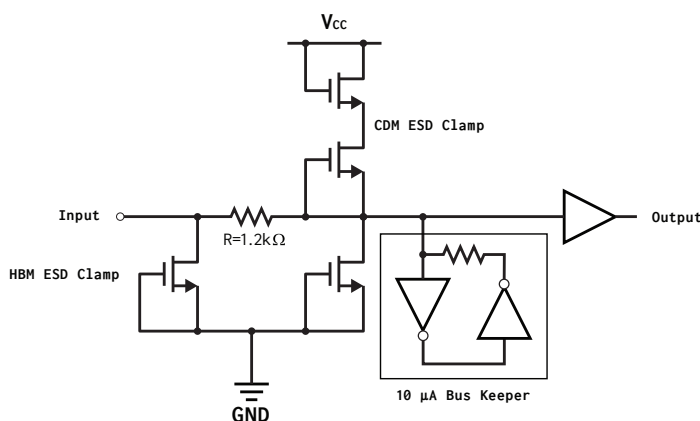

**Figure 6:** Details of input pin structure

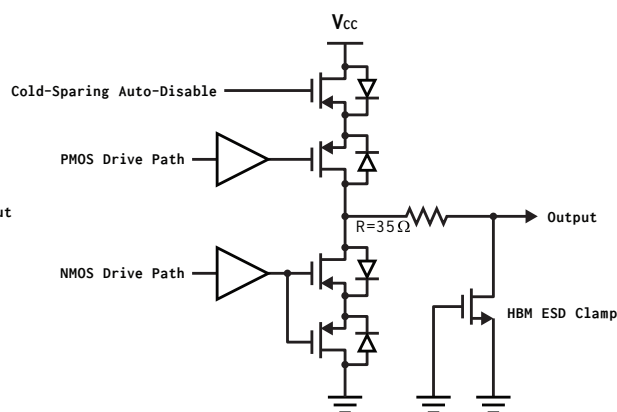

**Figure 7:** Details of output pin structure

## 7 APPLICATIONS INFORMATION

The AP54RHC505 provides a simple and robust means of interfacing digital logic between different voltage levels and domains. It can shift logic signals up from a lower voltage to a higher voltage or shift signals down from higher to lower voltages.

As seen in Table 1, the AP54RHC505 offers several features that make interfacing between different domains simple. First, the absence of an input supply voltage results in a tri-state condition at the output. Second, the outputs may also be tri-stated through assertion of the  $\overline{EN}$  pin, which can be tied with power-supply enables or other control signals.

With the bus keeping feature on all inputs, the AP54RHC505 is capable of maintaining an output state even if an input is left floating. For example, this may be as a result of an input being connected to a tri-state output that has been placed in the tri-state mode after asserting the logic level of interest. In this scenario, the AP54RHC505 will not change output state unless the level being asserted at the input is accompanied by a current driving capability beyond that of the bus keeper.

In an application utilizing a modern FPGA with 1.8 V I/O buffers that needs to interface to systems running at higher voltages (i.e. 5 V), the AP54RHC505 can be used to shift these signals to a range appropriate for the FPGA. The AP54RHC505 provides integrated triple modular redundancy (TMR), as well as SET resiliency on each buffer. In the event the 5 V supply is off, the AP54RHC505 will automatically tri-state the output buffers. The  $\overline{EN}$  pin of the device can be tied to the FPGA power-enable logic such that  $\overline{EN}$  is de-asserted when the 1.8 V I/O rail is not present.

### 7.1 APPLICATIONS EXAMPLE

As the AP54RHC family is radiation-hardened by design and includes internal TMR, it can be utilized in high-reliability applications without additional supporting circuitry or devices. Nonetheless, some application requirements call for fully-redundant designs, where an “A” and a “B” device are required, often on separate power rails.

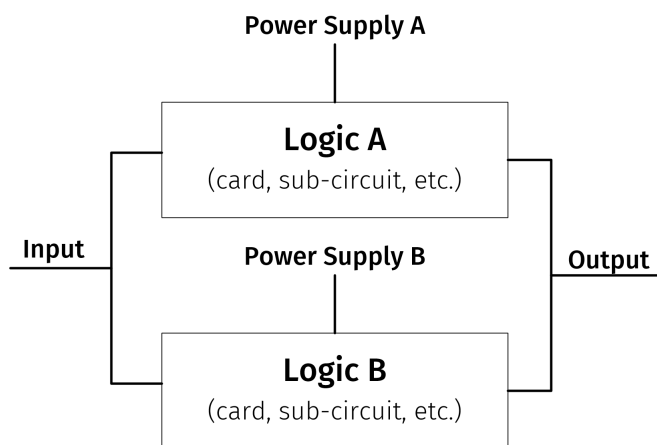

**Figure 8:** Cold sparing example.

With the cold-sparing capability of the AP54RHC family, fully redundant “A” and “B” functions may be placed in parallel (as seen in Figure 8) running off redundant power supplies. The inputs and outputs on each one of these functions are assumed to be based on the AP54RHC family, allowing for direct parallel connection without unwanted leakage current paths during cold sparing. In the event of a failure in power supply A or within function A, the system can simply shut power supply A off and switch on power supply B, without requiring additional input or output switching or configuration changes.

## 7.2 POWER SUPPLY RECOMMENDATIONS

This device can operate at any voltage within the range specified in [Table 4 Recommended Operating Conditions](#).

At a minimum, a 16 VDC (or higher), X7R-rated 0.1  $\mu$ F ceramic decoupling capacitor should be placed near (within 1 cm) the  $V_{CC}$  pins of the device.

## 7.3 APPLICATION TIPS

Unused inputs of the level translator may be left floating, due to the internal bus-keeping feature. However, the output state of the device is undefined if the inputs are left floating when powering up the device — a valid logic level must be asserted at each input for the bus keeper to capture its state.

The  $\overline{EN}$  pin of the device does **not** have a bus keeper function, and an external resistor is recommended to set a known-state on this pin if not driven by external logic.

An unused **output** may be left floating. It is suggested that it be routed to a test point or similar accessible structure in case the associated function needs to be utilized as part of a design revision.

## 8 PACKAGING INFORMATION

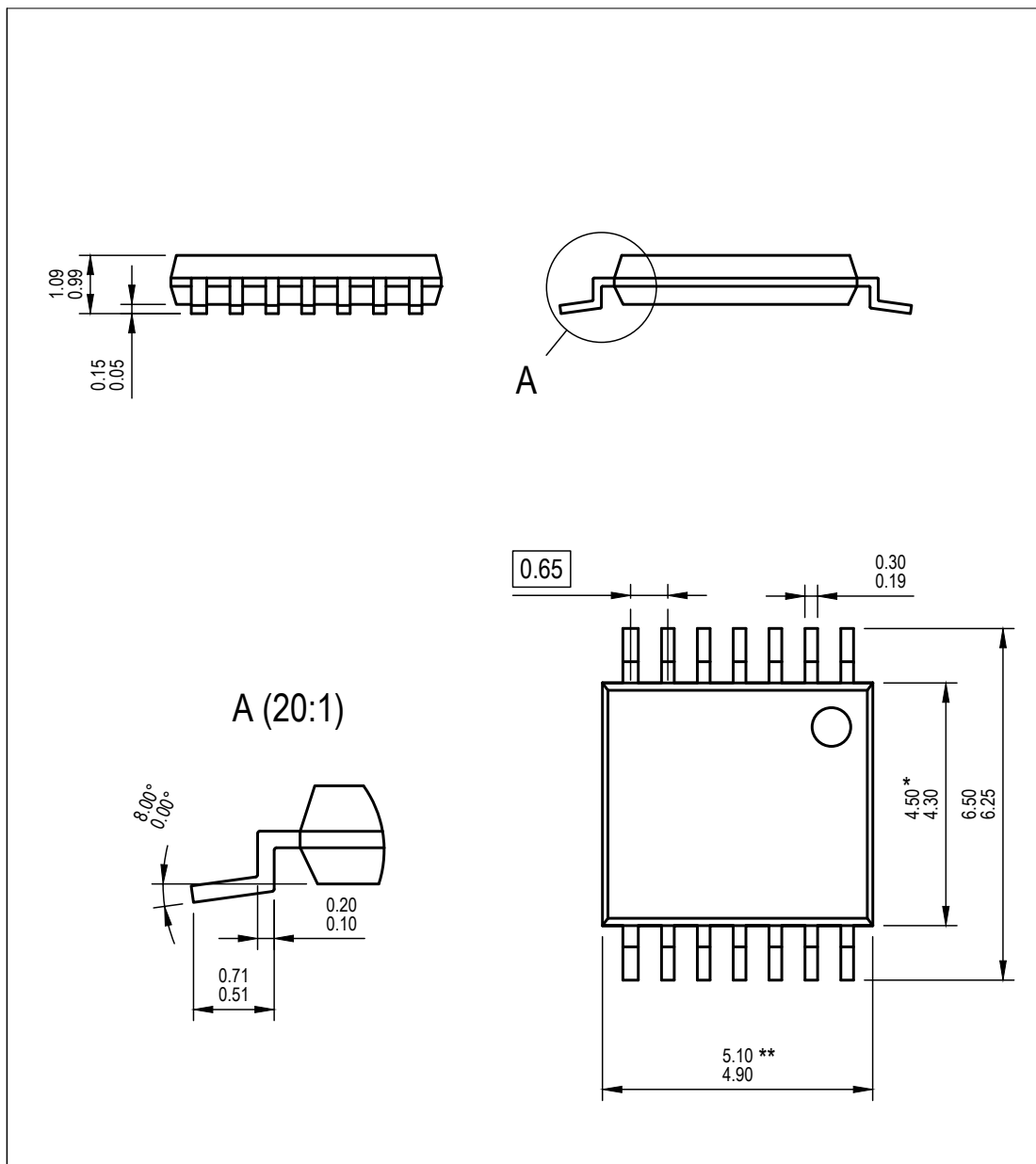

**Notes:**

1. All linear dimensions are in millimeters. Dimensioning and tolerancing are as per ISO/TS 128-71:2010
2. The part is compliant with JEDEC MO-153 specifications.

\* Body width does **not** include interlead flash. Interlead flash shall not exceed 0.25 mm each side.

\*\* Body length does **not** include mold flash, protrusion, or gate burrs. Mold flash, protrusions, and gate burrs shall not exceed 0.15 mm on each side.

**Figure 9:** Package Mechanical Detail

## 9 ORDERING INFORMATION

Example part numbers for the AP54RHC505 are listed in Table 9. The full list of options for this part can be found in Figure 10. Please contact Apogee Semiconductor sales at [sales@apogeesemi.com](mailto:sales@apogeesemi.com) for further information on sampling, lead time and purchasing on specific part numbers.

**Table 9:** AP54RHC505 Ordering Information

DEVICE	DESCRIPTION	PACKAGE
AP54RHC505ELT-W	Radiation Hardened 5-channel Level Translator (for evaluation only)	Plastic TSSOP-14
AP54RHC505ALT-R	Radiation Hardened 5-channel Level Translator (30 krad (Si))	Plastic TSSOP-14

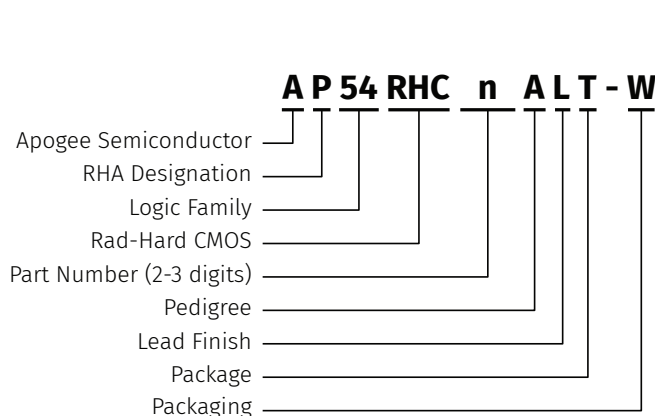

**Figure 10:** Part Number Decoder

- RHA Designation  
**P** 30 krad (Si)
- Part Number  
**505** (5-channel level translator with 3-state outputs and bus-keepers)
- Pedigree  
**A** -55 to +125 °C (Burn-in)  
**B** -55 to +125 °C (No burn-in)  
**E** 25 °C Functional Test Only (Evaluation)
- Lead Finish  
**L** Tin-Lead (SnPb)
- Package  
**T** 14-pin Thin Shrink Small Outline Package (TSSOP)
- Packaging  
**W** Waffle Pack or Pillow Stat Box  
**R** Tape and Reel<sup>(1)</sup>

<sup>(1)</sup> [Contact us](#) for custom reel quantities. Orders less than full reel quantities may be shipped as cut tape.

## 10 REVISION HISTORY

REVISION	DESCRIPTION	DATE
A04	Updated ordering information.	2021-07-30
A03	Updated Static and Dynamic characteristics from test data.	2021-06-23
A02	Update Static and Dynamic characteristics.	2020-08-07
A01	Initial public release.	2020-02-29
A00	Initial internal release.	2019-07-05

For the latest version of this document, please visit <https://www.apogeesemi.com>.