

DESCRIPTION

The AP62300/AP62301/AP62300T is a 3A, synchronous buck converter with a wide input voltage range of 4.2V to 18V. The device fully integrates a 75mΩ high-side power MOSFET and a 45mΩ low-side power MOSFET to provide high-efficiency step-down DC-DC conversion.

The AP62300/AP62301/AP62300T device is easily used by minimizing the external component count due to its adoption of Constant On-Time (COT) control to achieve fast transient response, easy loop stabilization, and low output voltage ripple.

The AP62300/AP62301/AP62300T design is optimized for Electromagnetic Interference (EMI) reduction. The device has a proprietary gate driver scheme to resist switching node ringing without sacrificing MOSFET turn-on and turn-off times, which reduces high-frequency radiated EMI noise caused by MOSFET switching.

AP62300/AP62301/300T is available in a TSOT26 package.

FEATURES

- V_{IN} Range: 4.2V -18V
- Output Voltage range: 0.8V to 7V
- 3A Continuous Output Current
- $0.8V \pm 1\%$ Reference Voltage ($T_A = +25^\circ C$) => AP62300 and AP62301
- $0.7625V \pm 1\%$ Reference Voltage ($T_A = +25^\circ C$) => AP62300T
- 155μA Low Quiescent Current
- 750kHz Switching Frequency
- Up to 83% Efficiency at 5mA Light Load
- Proprietary Gate Driver Design for Best EMI Reduction
- Protection Circuitry
 - Undervoltage Lockout (UVLO)
 - Cycle-by-Cycle Valley Current Limit
 - Thermal Shutdown
- Totally Lead-Free & Fully RoHS Compliant
- Halogen and Antimony Free. “Green” Device

APPLICATIONS

- Flat Screen TV Sets and Monitors
- Set Top Boxes
- Consumer Electronics
- Network Systems
- General Purpose Point of Load

TYPICAL APPLICATIONS CIRCUIT

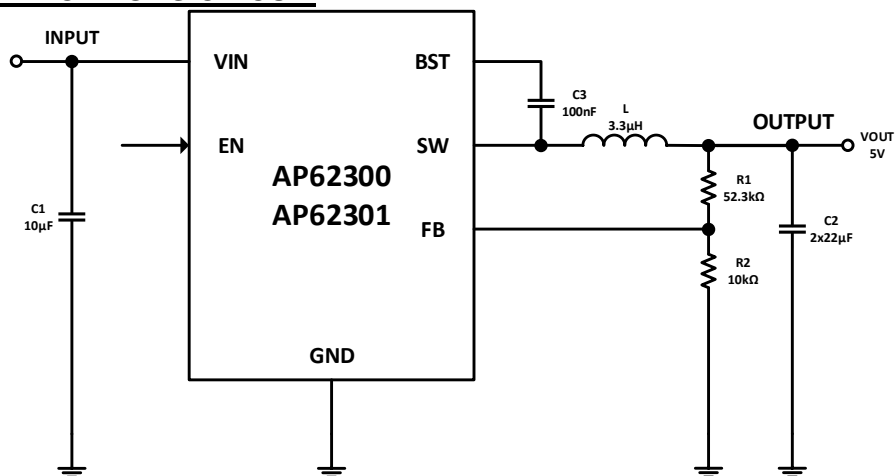

Figure 1. Typical Application Circuit

ABSOLUTE MAXIMUM RATINGS

Symbol	Parameter	Rating	Unit
VIN	Supply Pin Voltage	-0.3 to +20.0 (DC)	V
		-0.3 to 22.0 (400ms)	
V _{SW}	Switch Pin Voltage	-1.0 to VIN + 0.3 (DC)	V
		-2.5 to VIN + 2.0 (20ns)	
V _{BST}	Bootstrap Pin Voltage	V _{SW} - 0.3 to V _{SW} + 6.0	V
V _{EN}	Enable/UVLO Pin Voltage	-0.3 to +6.0	V
V _{FB}	Feedback Pin Voltage	-0.3 to +6.0	V
T _{ST}	Storage Temperature	-65 to +150	°C
T _J	Junction Temperature	+150	°C
T _L	Lead Temperature	+260	°C
ESD Susceptibility			
HBM	Human Body Mode	2000	V
CDM	Charge Device Model	500	V

RECOMMENDED OPERATING CONDITIONS

Symbol	Parameter	Rating	Unit
V _{IN}	Supply Voltage	4.2 to 18	V
V _{OUT}	Output Voltage Range	0.8 to 7	V
T _A	Operating Ambient Temperature	-40 to +85	°C
T _J	Operating Junction Temperature	-40 to +125	°C

SETTING OUTPUT VOLTAGE:

Table 1 for **AP62300** and AP62301 shows a list of recommended component selections for common output voltages.

Vout	R1	R2	L1
1.2V	4.99KΩ	10KΩ	1.5μH
1.5V	8.66KΩ	10KΩ	1.5μH
1.8V	12.4KΩ	10KΩ	2.2μH
2.5V	21.5KΩ	10KΩ	2.2μH
3.3V	31.6KΩ	10KΩ	3.3μH
5.0V	52.3KΩ	10KΩ	3.3μH

Table 1. Common Output Voltages (AP62300/301)

Table 2 for AP62300T shows a list of recommended component selections for common output voltages.

Vout	R1	R2	L1
1.2V	5.76KΩ	10KΩ	1.5μH
1.5V	9.76KΩ	10KΩ	1.5μH
1.8V	13.7KΩ	10KΩ	2.2μH
2.5V	22.6KΩ	10KΩ	2.2μH
3.3V	33.2KΩ	10KΩ	3.3μH
5.0V	56.2KΩ	10KΩ	3.3μH

Table 2. Common Output Voltages (AP62300T)

EVALUATION BOARD

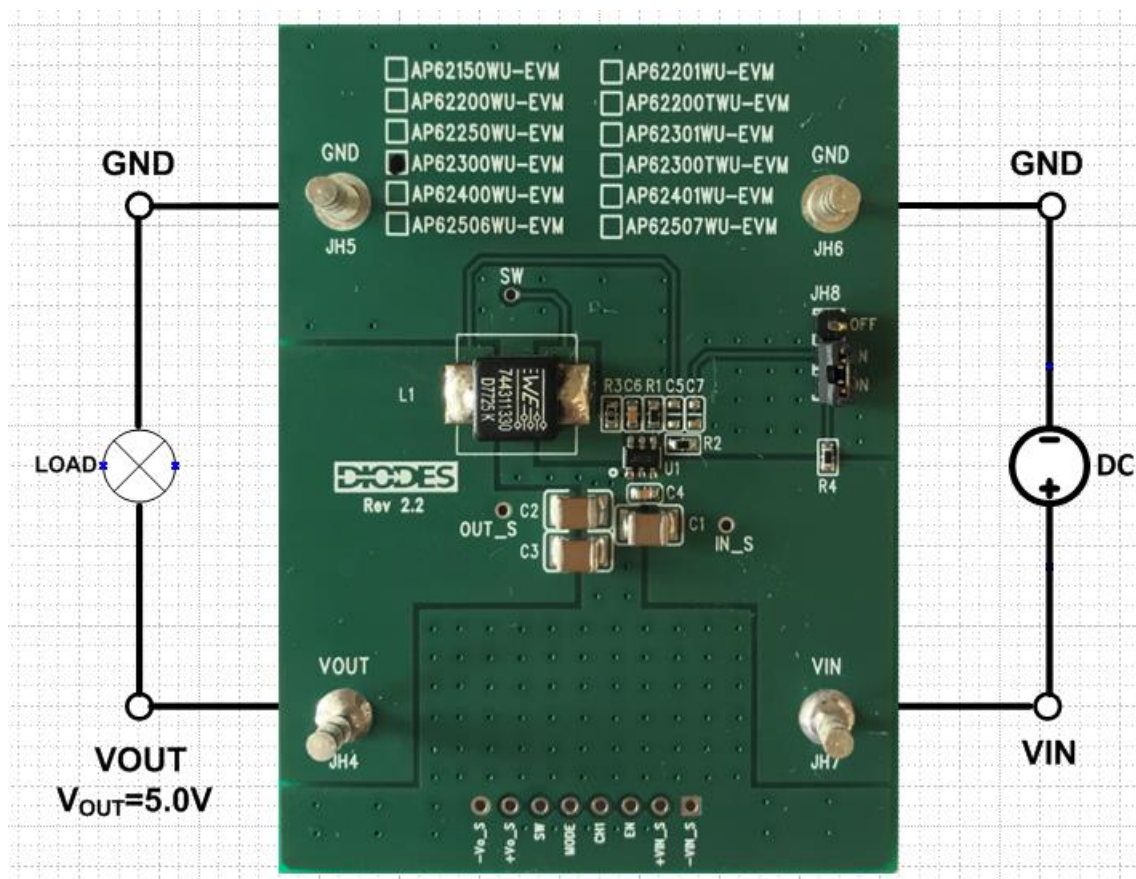

Figure 2. AP62300WU-EVM

QUICK START GUIDE

The AP62300/301/300TWU-EVM has a simple layout and allows access to the appropriate signals through test points. To evaluate the performance of the AP62300/301/300TWU, follow the procedure below:

1. Connect a power supply to the input terminals VIN and GND. Set VIN to 12V.
2. Connect the positive terminal of the electronic load to VOUT and negative terminal to GND.
3. For Enable, place a jumper at JH8 to "ON" position to connect EN pin to VIN through 100KΩ resistor to enable IC or leave it OPEN. Jump to "OFF" position to disable IC.
4. The evaluation board should now power up with a 5.0V output voltage.

5. Check for the proper output voltage of 5.0V ($\pm 1\%$) at the output terminals V_{OUT} and GND. Measurement can also be done with a multimeter with the positive and negative leads between V_{OUT} and GND.
6. Set the load to 3A through the electronic load. Check for the stable operation of the SW signal on the oscilloscope. Measure the switching frequency.

MEASUREMENT/PERFORMANCE GUIDELINES:

- 1) When measuring the output voltage ripple, maintain the shortest possible ground lengths on the oscilloscope probe. Long ground leads can erroneously inject high frequency noise into the measured ripple.
- 2) For efficiency measurements, connect an ammeter in series with the input supply to measure the input current. Connect an electronic load to the output for output current.

EVALUATION BOARD SCHEMATIC

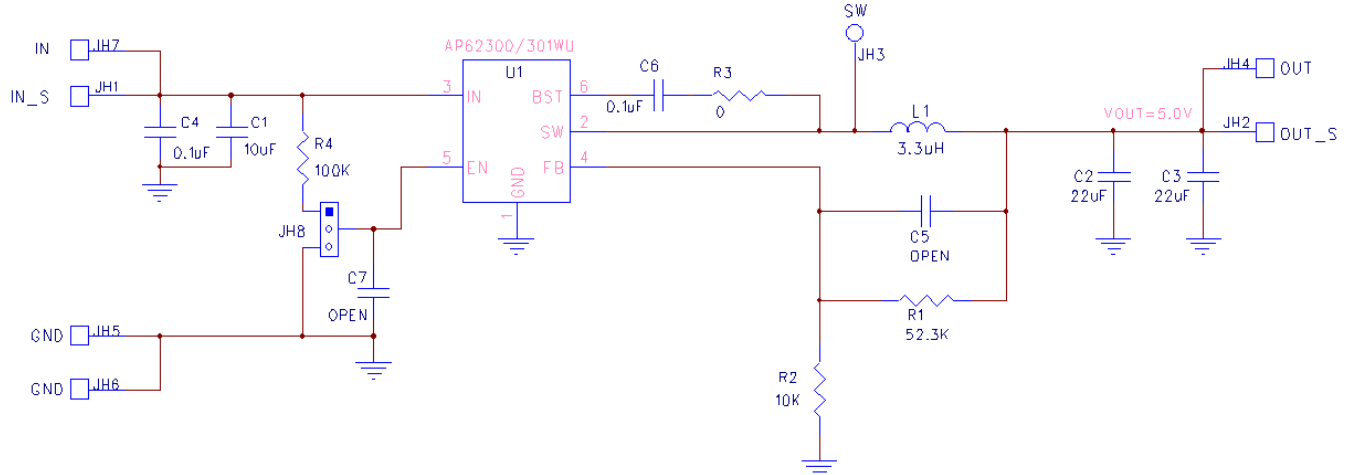

Figure 3. AP62300/301WU-EVM Schematic

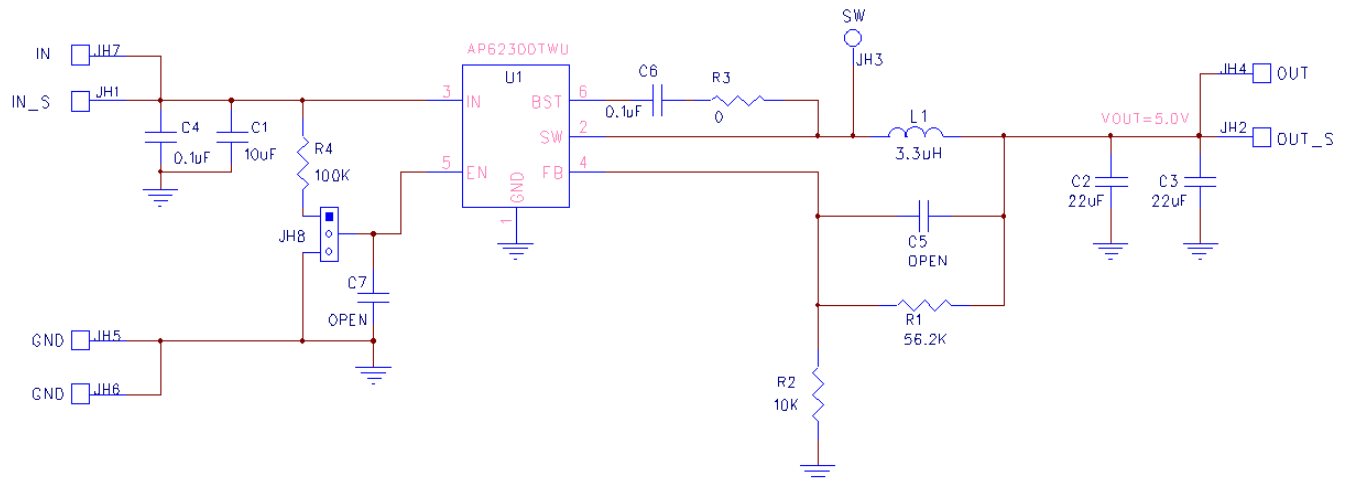

Figure 4. AP62300TWU-EVM Schematic

BILL OF MATERIALS for AP62300/301WU-EVM for $V_{OUT}=5V$

Ref	Value	Description	Qty	Size	Vendor Name	Manufacturer PN
C1	10 μ F	Ceramic Capacitor, 25V, X7R, 10%	1	1210	KEMET	C1210C106K3RACTU
C2, C3	22 μ F	Ceramic Capacitor, 25V, X7R, 10%	2	1210	KEMET	C1210C226K3RAC7800
C4, C6	0.1 μ F	Ceramic Capacitor, 50V, X7R, 10%	2	0603	KEMET	C0603C104K5RACTU
L1	3.3 μ H	DCR=10.5m Ω , Ir=7.5A	1	10x10x5mm	Würth Electronics	7447714033
R1	52.3K Ω	SMD Resistor, 1%	1	0603	Panasonic	ERJ-3EKF5232V
R2	10K Ω	SMD Resistor, 1%	1	0603	Panasonic	ERJ-3EKF1002V
R3	0 Ω	SMD Resistor, 1%	1	0603	Panasonic	ERJ-3GEY0R00V
R4	100K Ω	SMD Resistor, 1%	1	0603	Panasonic	ERJ-3EKF1003V
JH4, JH5, JH6, JH7	1598	Terminal Turret Triple 0.094" L (Test Points)	4	Through-Hole	Keystone Circuit	1598-2
JH8		PCB Header, 40 POS	1	1X3	3M	2340-6111TG
U1	AP62300	Sync Buck DC/DC converter	1	TSOT26	Diodes Inc	AP62300WU-7

TYPICAL PERFORMANCE CHARACTERISTICS

