

Description

The AP7354 is a low dropout regulator with high output voltage accuracy. The AP7354 includes a voltage reference, error amplifier, current limit circuit, and an enable input to turn it on/off. With the integrated resistor network, fixed output voltage versions can be delivered.

With its ultra-low quiescent current, the AP7354 is well-suited for low-power handheld, wearable devices, and other battery-operated devices requiring an extended time period until new battery replacement.

The AP7354 is available in SOT23, SOT25, and X2-DFN1010-4 (Type B) packages.

Features

- Wide V_{IN} Range: 2.0V to 5.5V
- Guarantee Output Current: 150mA
- Output Voltage Range: 1.1V to 4.5V
- V_{OUT} Accuracy: $\pm 1\%$
- Quiescent Current as Low as 0.25 μ A
- Output Discharge Available for Devices in SOT25 or X2-DFN1010-4 (Type B)
- Typical Standby Current: 0.02 μ A
- ESD Protection Exceeds JESD 22
 - Exceeds 4000V Human Body Model (A114)
 - Exceeds 400V Machine Model (A115)
- Latch-Up Exceeds 400mA per JESD 78, Class I
- Moisture Sensitivity: Level 1 per J-STD-020
- Terminals:
 - SOT23/SOT25: Finish - Matte Tin Plated Leads, Solderable per MIL-STD-202, Method 208^(e3)
 - X2-DFN1010-4 (Type B): Finish - NiPdAu over Copper Leads, Solderable per MIL-STD-202, Method 208^(e4)
- Weight:
 - SOT23: 0.009 grams (Approximate)
 - SOT25: 0.016 grams (Approximate)
 - X2-DFN1010-4 (Type B): 0.001 grams (Approximate)
- **Totally Lead-Free & Fully RoHS Compliant (Notes 1 & 2)**
- **Halogen and Antimony Free. "Green" Device (Note 3)**
- **For automotive applications requiring specific change control (i.e. parts qualified to AEC-Q100/101/200, PPAP capable, and manufactured in IATF 16949 certified facilities), please [contact us](https://www.diodes.com/quality/product-definitions/) or your local Diodes representative.**

<https://www.diodes.com/quality/product-definitions/>

Pin Assignments

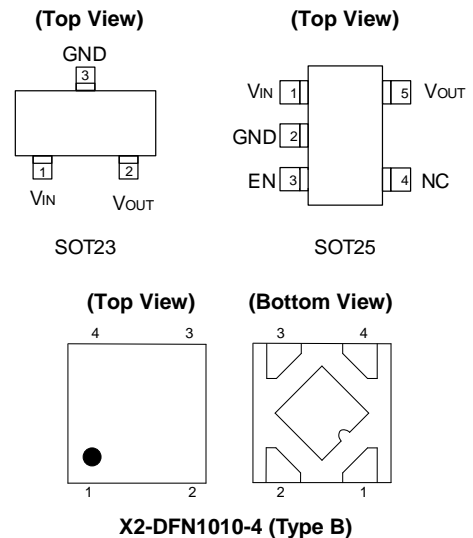

Pin 1 – V_{OUT} , Pin 2 – GND, Pin 3 – EN, Pin 4 – V_{IN}

Applications

- Wearable Electronics
- Sensor Module for Internet-of-Things (IoT)
- Wireless Communication Module
- Battery-Operated Device
- Camera
- Image Sensor

Typical Applications Circuit (Note 4)

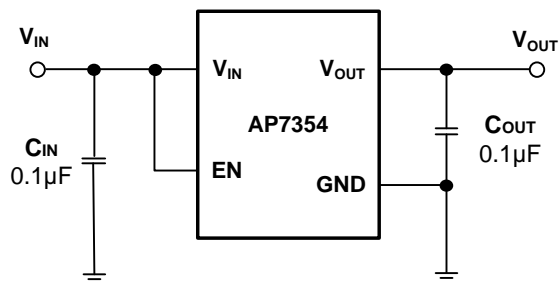

- Notes:
1. No purposely added lead. Fully EU Directive 2002/95/EC (RoHS), 2011/65/EU (RoHS 2) & 2015/863/EU (RoHS 3) compliant.
 2. See <https://www.diodes.com/quality/lead-free/> for more information about Diodes Incorporated's definitions of Halogen- and Antimony-free, "Green" and Lead-free.
 3. Halogen- and Antimony-free "Green" products are defined as those which contain <900ppm bromine, <900ppm chlorine (<1500ppm total Br + Cl) and <1000ppm antimony compounds.
 4. X5R- and X7R-type capacitors are suggested due to their minimal variation in value and ESR over temperature.

Pin Description

| Pin Number | | | Pin Name | Function |
|------------|-------|-----------------------|------------------|--|
| SOT25 | SOT23 | X2-DFN1010-4 (Type B) | | |
| 3 | — | 3 | EN | Chip Enable — This should be driven either high or low and must not be floating. Driving EN high enables regulator output, while pulling it low places regulator into shutdown mode. |
| 2 | 3 | 2 | GND | Ground |
| 5 | 2 | 1 | V _{OUT} | Output Voltage |
| 1 | 1 | 4 | V _{IN} | Power Input |
| — | — | Center Pad | — | No connection or ground. Note: Chip Ground must be through GND pin. |

Functional Block Diagram

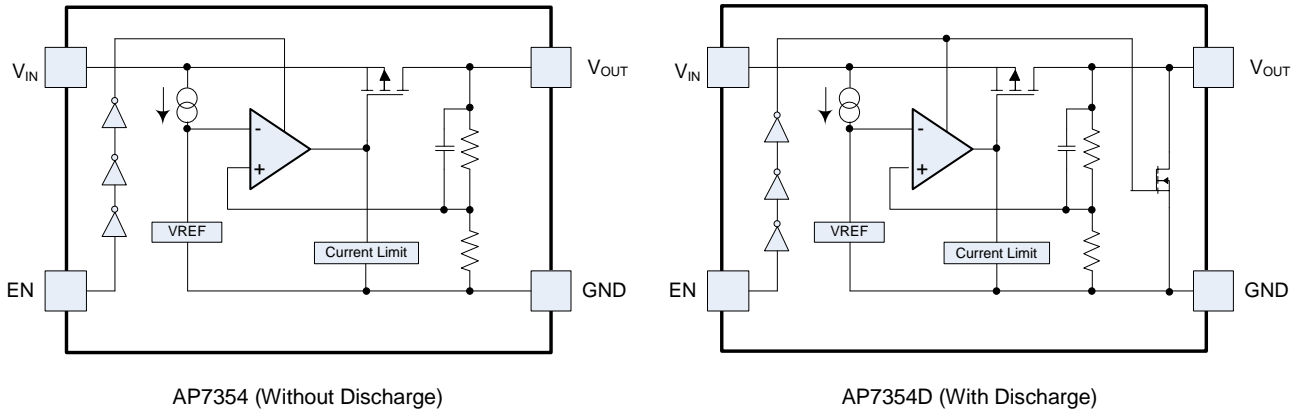

EN Pin Not Available on SOT23

Absolute Maximum Ratings (Note 5)

| Symbol | Parameter | Rating | Unit |
|------------------|---------------------------------|------------------------------|------|
| ESD HBM | Human Body Model ESD Protection | 4 | kV |
| ESD MM | Machine Model ESD Protection | 400 | V |
| V _{IN} | Input Voltage | 6.0 | V |
| V _{EN} | Input Voltage at EN Pin | 6.0 | V |
| V _{OUT} | Output Voltage to GND | -0.3 to V _{IN} +0.3 | V |
| T _A | Operating Ambient Temperature | -40 to +85 | °C |
| T _J | Maximum Junction Temperature | +125 | °C |
| T _{STG} | Storage Temperature | -55 to +125 | °C |
| P _D | Power Dissipation (Note 6) | 315 | mW |

- Notes:
5. Stresses beyond those listed under *Absolute Maximum Ratings* can cause permanent damage to the device. These are stress ratings only and functional operation of the device at these conditions is not implied. Exposure to absolute-maximum-rated conditions for extended periods can affect device reliability.
 6. This is based on an application temperature of +40°C. Derate 3.75mW per °C for each degree above +40°C.

Recommended Operating Conditions

| Symbol | Parameter | Min | Max | Unit |
|------------------|-------------------------------|-----|-----|------|
| V _{IN} | Input Voltage | 2.0 | 5.5 | V |
| I _{OUT} | Output Current | 0 | 150 | mA |
| T _A | Operating Ambient Temperature | -40 | +85 | °C |

Electrical Characteristics (@ $T_A = +25^\circ\text{C}$, $V_{EN} = V_{IN} = V_{OUT} + 1\text{V}$ ($1.5\text{V} < V_{OUT} \leq 4.5\text{V}$), $V_{EN} = V_{IN} = 2.5\text{V}$ ($V_{OUT} \leq 1.5\text{V}$), $I_{OUT} = 1\text{mA}$, $C_{IN} = C_{OUT} = 0.1\mu\text{F}$, unless otherwise specified.)

| Parameter | Conditions | Min | Typ | Max | Unit | |
|--|---|--|------|------|---------------|---------------------------|
| Input Voltage | $T_A = -40^\circ\text{C}$ to $+85^\circ\text{C}$ | 2.0 | — | 5.5 | V | |
| Output Voltage Accuracy | $V_{OUT} > 2.0\text{V}$ $I_{OUT} = 1\text{mA}$ | $T_A = +25^\circ\text{C}$ | -1 | — | +1 | % |
| | | $T_A = -40^\circ\text{C}$ to $+85^\circ\text{C}$ | -2 | — | +2 | |
| | $V_{OUT} \leq 2.0\text{V}$ $I_{OUT} = 1\text{mA}$ | $T_A = +25^\circ\text{C}$ | -40 | — | 40 | mV |
| | | $T_A = -40^\circ\text{C}$ to $+85^\circ\text{C}$ | -80 | — | 80 | |
| Line Regulation ($\Delta V_{OUT}/\Delta V_{IN}/V_{OUT}$) | $\text{MAX}(V_{OUT} + 1.0\text{V}, 2.5\text{V}) \leq V_{IN} \leq 5.5\text{V}$ (All Versions Except 4.5V) | — | 0.02 | 0.1 | %/V | |
| Load Regulation (ΔV_{OUT}) | $1\text{mA} \leq I_{OUT} \leq 150\text{mA}$ (All Versions Except 4.5V) | -40 | — | 40 | mV | |
| | $1\text{mA} \leq I_{OUT} \leq 150\text{mA}$ (Applicable to 4.5V Version) | -55 | — | 55 | mV | |
| Short Circuit Current Limit (Note 7) | $V_{OUT} = 0\text{V}$ | — | 60 | — | mA | |
| Quiescent Current (Note 8) | $I_{OUT} = 0\text{mA}$ | — | 0.25 | 0.6 | μA | |
| I_{STANDBY} | Set EN Low, No Load | — | 0.02 | 0.2 | μA | |
| Output Current | — | 150 | — | — | mA | |
| Dropout Voltage (Note 9) | $I_{OUT} = 150\text{mA}$ | $V_{OUT} = 1.1\text{V}$ | — | 0.70 | 1.00 | V |
| | | $V_{OUT} = 1.2\text{V}$ | — | 0.60 | 0.90 | |
| | | $V_{OUT} = 1.5\text{V}$ | — | 0.43 | 0.75 | |
| | | $V_{OUT} = 1.8\text{V}$ | — | 0.33 | 0.60 | |
| | | $V_{OUT} = 1.85\text{V}$ | — | 0.32 | 0.58 | |
| | | $V_{OUT} = 2.2\text{V}$ | — | 0.27 | 0.52 | |
| | | $V_{OUT} = 2.5\text{V}$ | — | 0.22 | 0.48 | |
| | | $V_{OUT} = 2.8\text{V}$ | — | 0.19 | 0.40 | |
| | | $V_{OUT} = 3.0\text{V}$ | — | 0.18 | 0.35 | |
| | | $V_{OUT} = 3.3\text{V}$ | — | 0.16 | 0.35 | |
| $V_{OUT} = 4.5\text{V}$ | — | 0.14 | 0.35 | | | |
| EN Input Low Voltage | — | — | — | 0.4 | V | |
| EN Input High Voltage | — | 1.0 | — | 5.5 | V | |
| Active Output Discharge Resistance (Note 10) | $V_{IN} = 4.0\text{V}$, $V_{EN} = 0\text{V}$ | — | 35 | — | Ω | |
| Θ_{JA} Thermal Resistance Junction-to-Ambient | (Note 11) | SOT23 | — | 170 | — | $^\circ\text{C}/\text{W}$ |
| | | SOT25 | — | 162 | — | |
| | | X2-DFN1010-4 (Type B) | — | 295 | — | |
| Θ_{JC} Thermal Resistance Junction-to-Case | (Note 11) | SOT23 | — | 43 | — | $^\circ\text{C}/\text{W}$ |
| | | SOT25 | — | 38 | — | |
| | | X2-DFN1010-4 (Type B) | — | 120 | — | |

- Notes:
- Short-circuit current is measured with V_{OUT} pulled to GND.
 - Quiescent current defined as the difference in current between the input and the output.
 - Dropout voltage is the voltage difference between the input and the output at which the output voltage drops 2% below its nominal value.
 - AP7354 is available with two options: built-in discharge (AP7354D) and non-discharge (AP7354).
 - Test condition: Device mounted on $1" \times 1"$ FR-4 MRP substrate PCB, 2oz copper, with minimum recommended pad layout.

Performance Characteristics

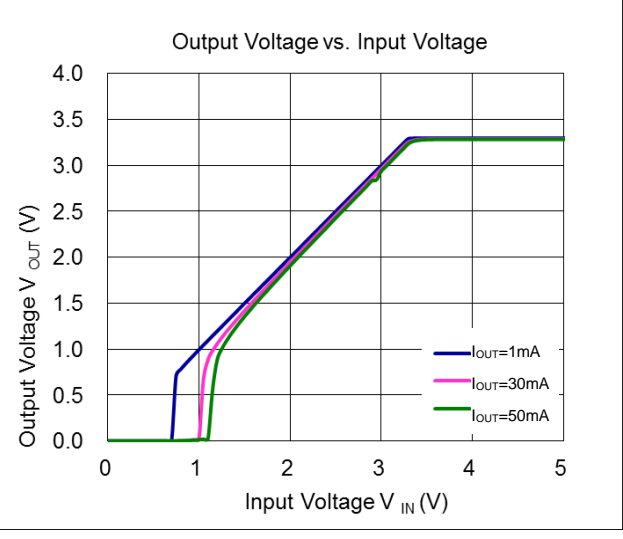
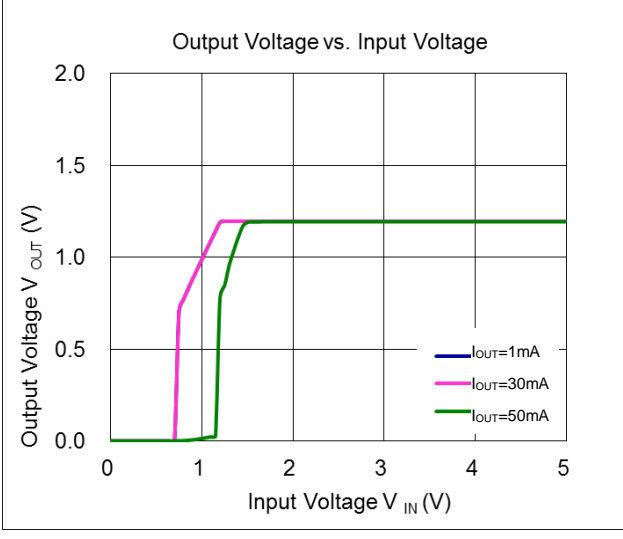
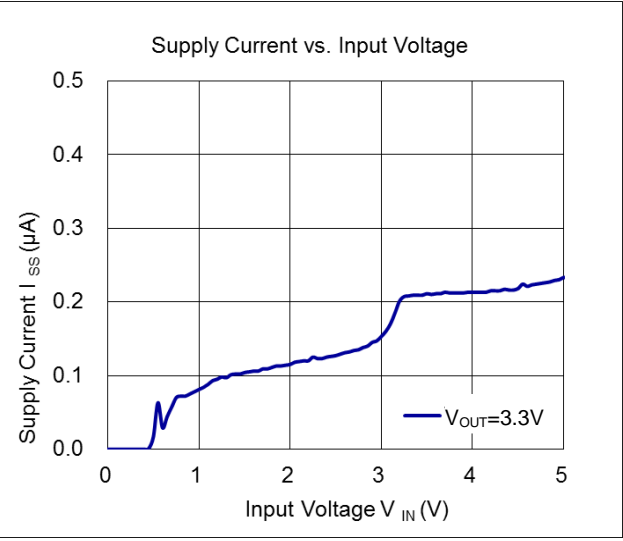
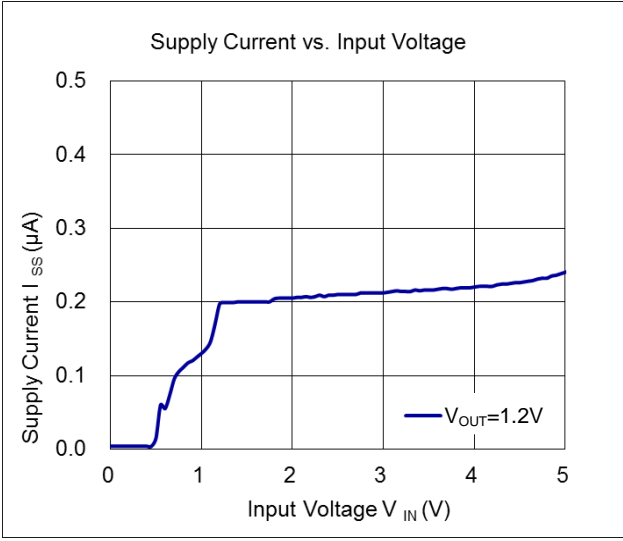
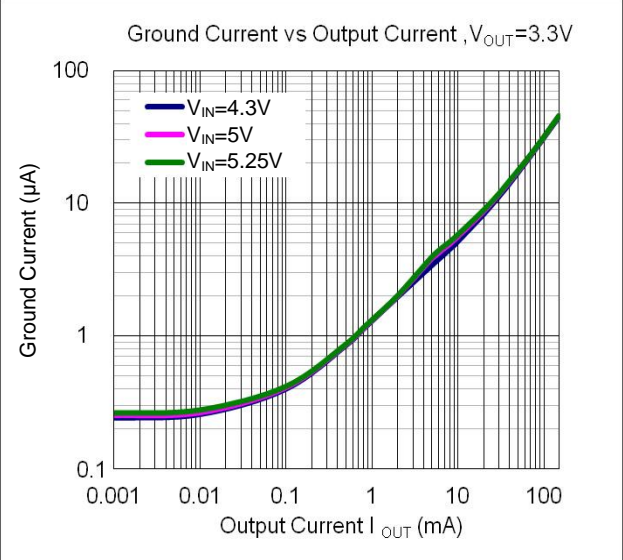
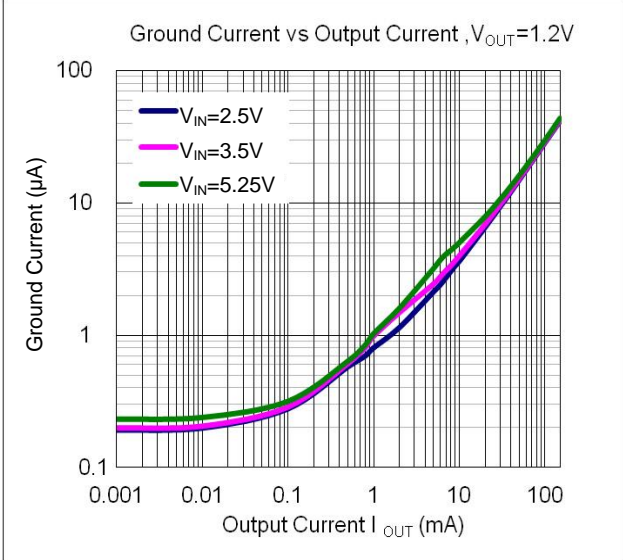

Performance Characteristics (continued)

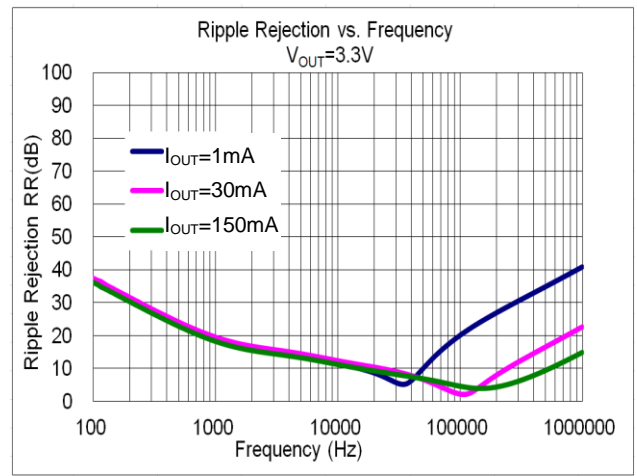
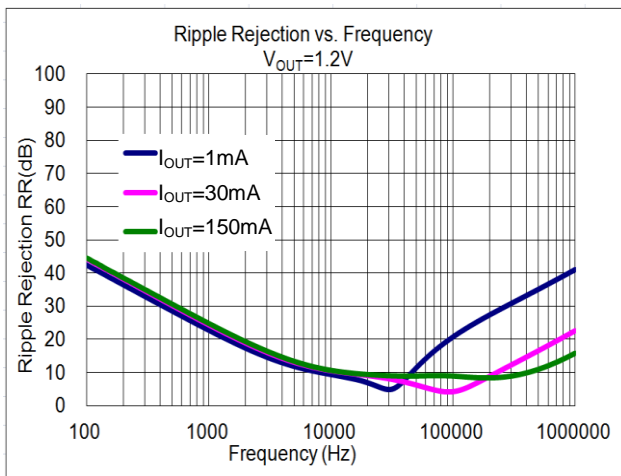
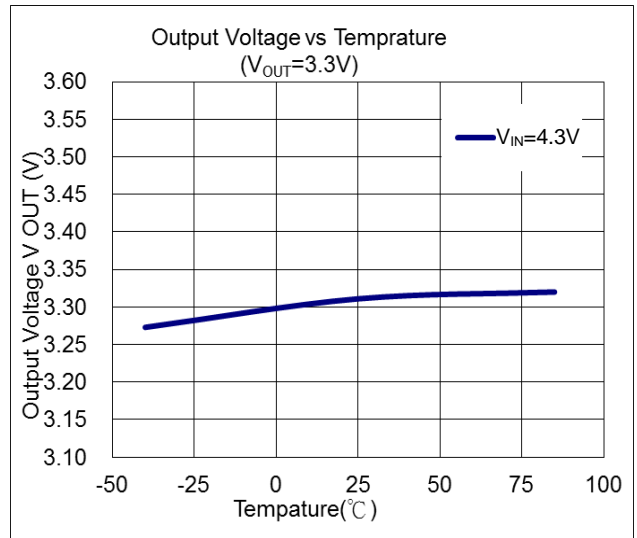
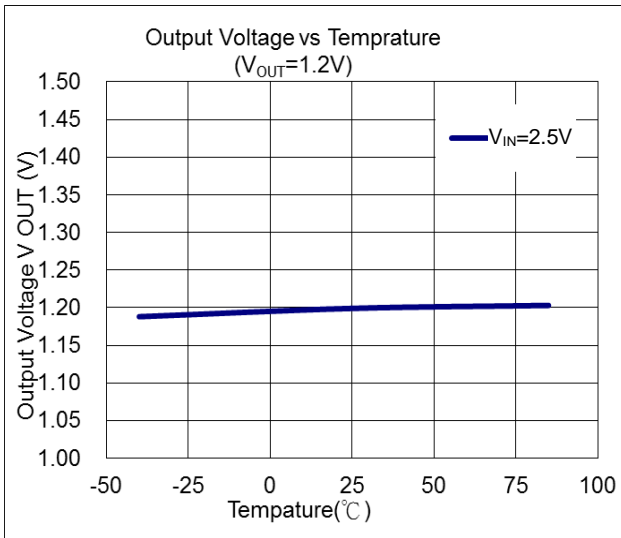
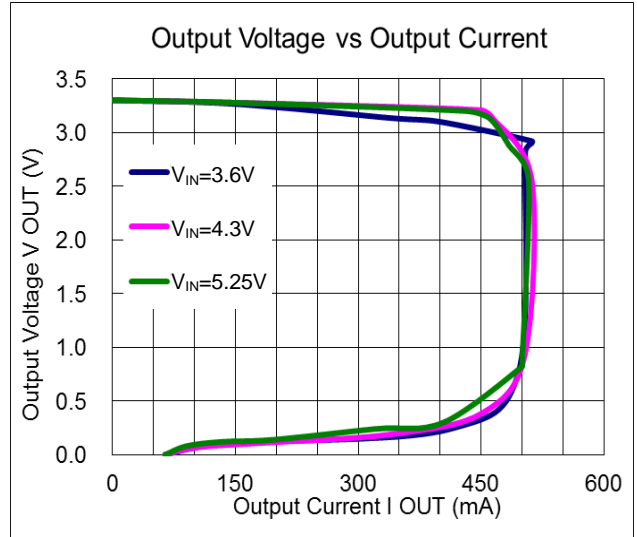
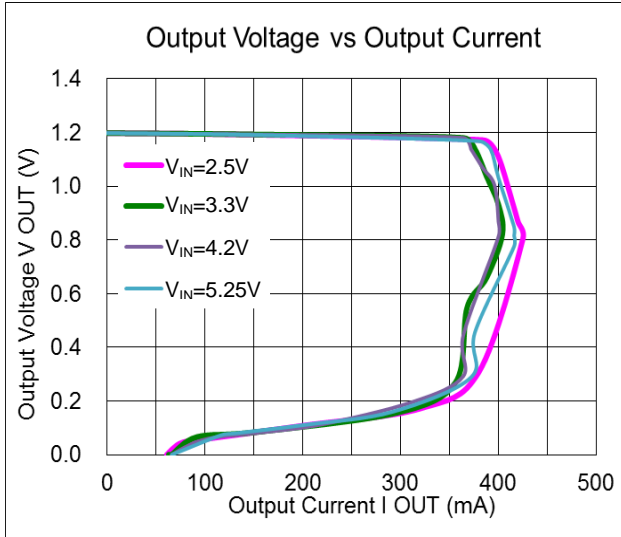

Performance Characteristics (continued)

Load Transient Response ($C_{IN} = C_{OUT} = 0.1\mu F$, $t_r = t_f = 5.0\mu s$, unless otherwise specified.)

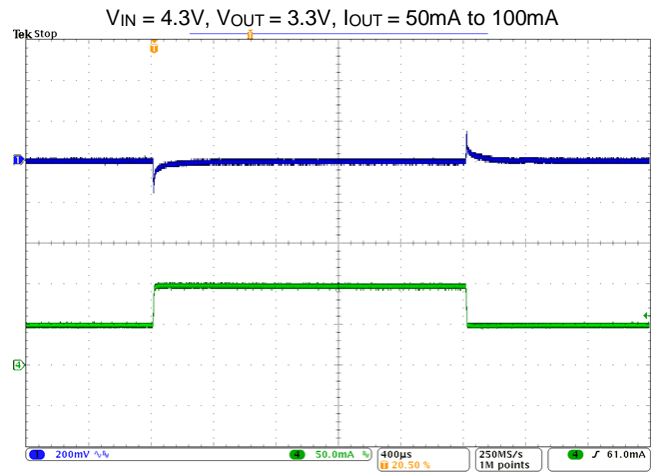
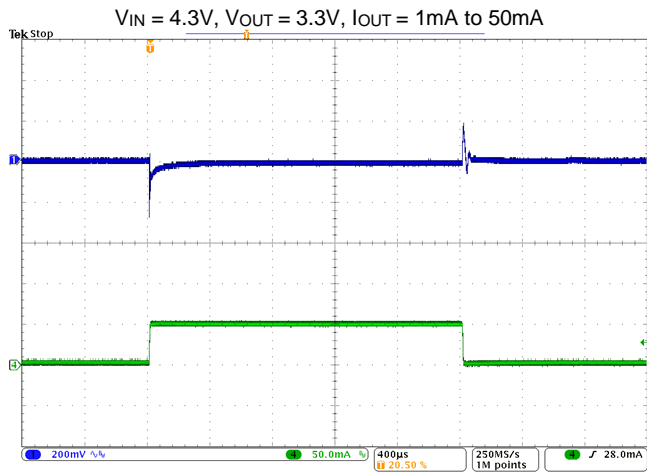
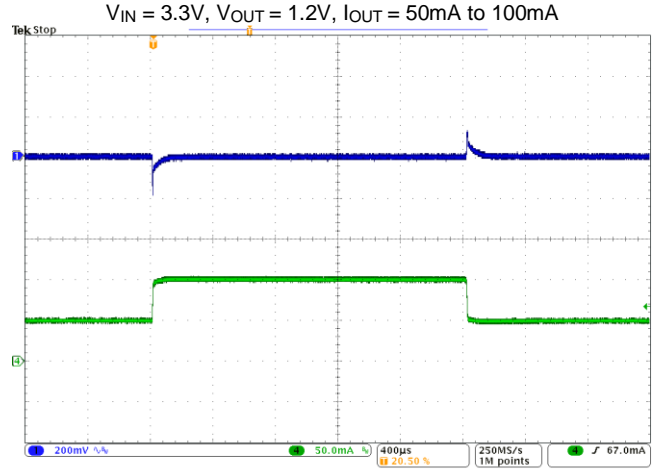
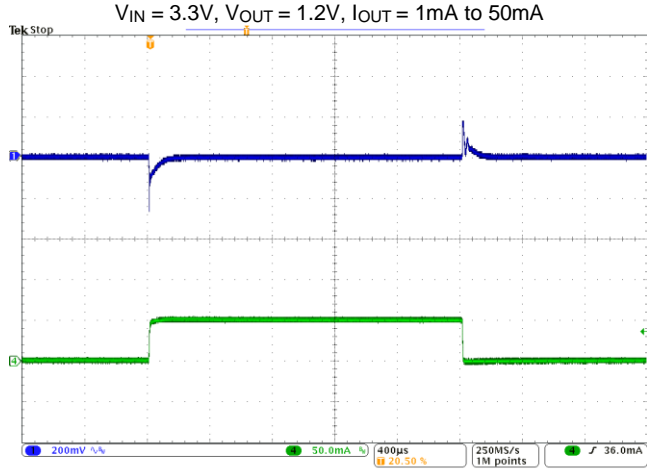

Performance Characteristics (continued)

TURN ON

$V_{IN} = 3.3V, V_{OUT} = 1.2V, I_{OUT} = 0mA, C_{IN} = C_{OUT} = 0.1\mu F$

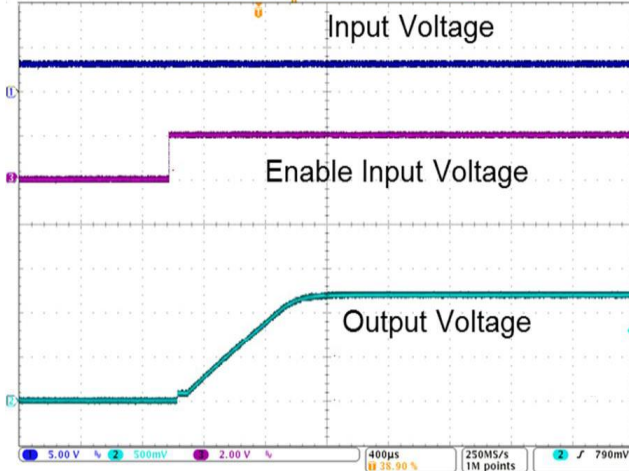

TURN OFF

$V_{IN} = 3.3V, V_{OUT} = 1.2V, I_{OUT} = 0mA, C_{IN} = C_{OUT} = 0.1\mu F$

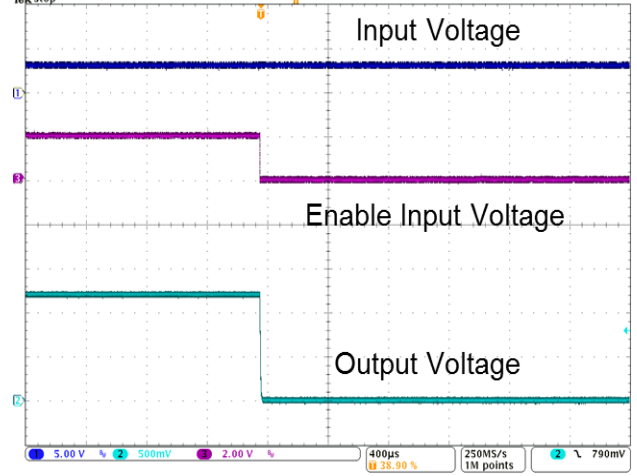

$V_{IN} = 3.3V, V_{OUT} = 1.2V, I_{OUT} = 150mA, C_{IN} = C_{OUT} = 0.1\mu F$

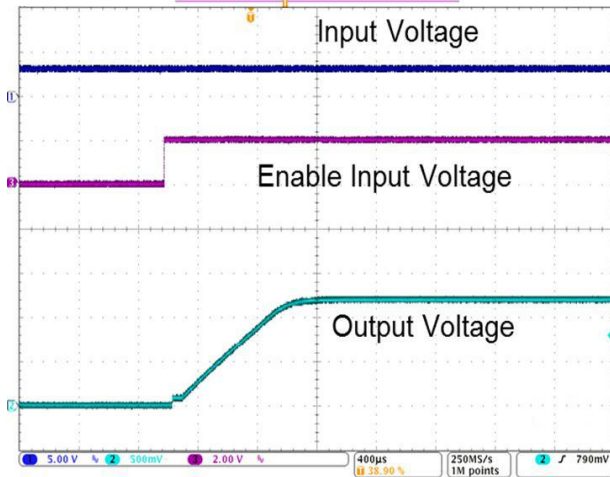

$V_{IN} = 3.3V, V_{OUT} = 1.2V, I_{OUT} = 150mA, C_{IN} = C_{OUT} = 0.1\mu F$

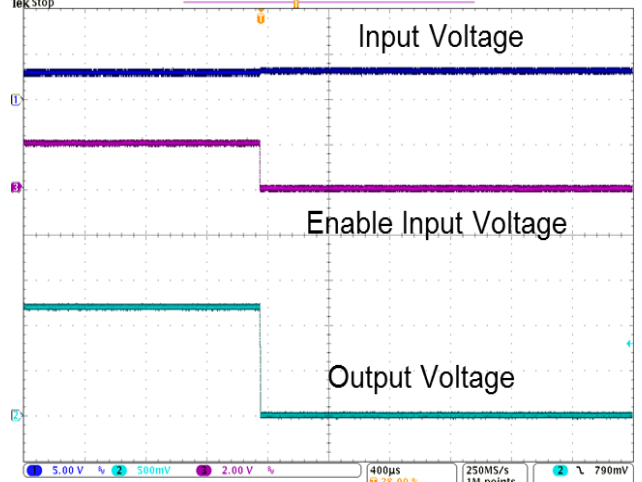

$V_{IN} = 4.3V, V_{OUT} = 3.3V, I_{OUT} = 0mA, C_{IN} = C_{OUT} = 0.1\mu F$

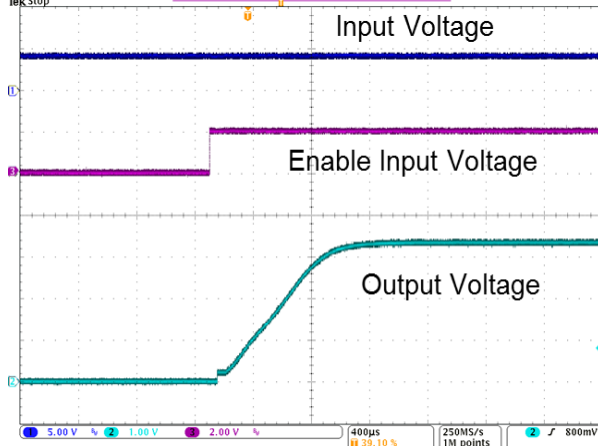

$V_{IN} = 4.3V, V_{OUT} = 3.3V, I_{OUT} = 0mA, C_{IN} = C_{OUT} = 0.1\mu F$

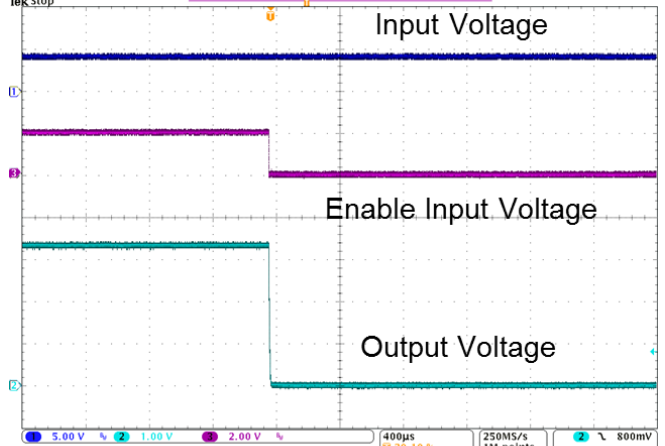

Performance Characteristics (continued)

TURN ON

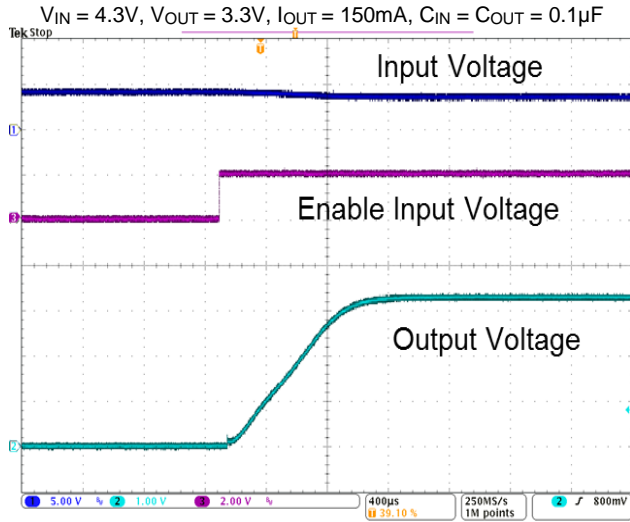

TURN OFF

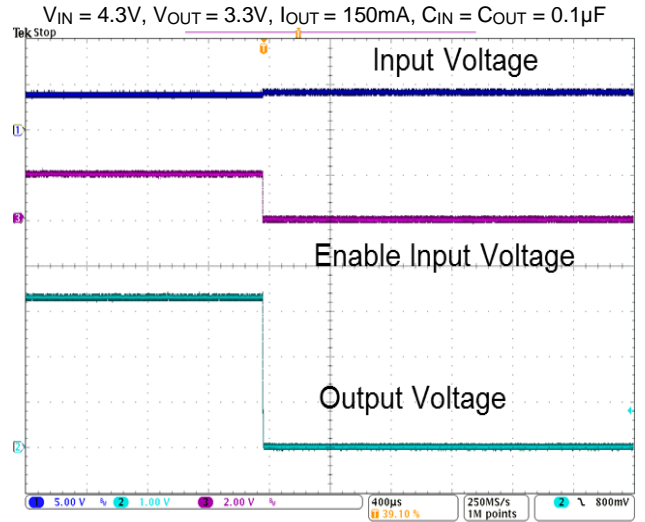

Application Information

Output Capacitor

An output capacitor (C_{OUT}) is required to improve transient response and maintain stability. The AP7354 is stable with very small ceramic output capacitors. The equivalent series resistance (ESR) and capacitance drive the selection. If the application has large load variations, it is recommended to utilize low-ESR bulk capacitors. It is recommended to place ceramic capacitors as close as possible to the load and the GND pin. Care must be taken to reduce the impedance in the layout.

Input Capacitor

To prevent the input voltage from dropping during load steps, it is recommended to utilize an input capacitor (C_{IN}). A minimum 0.1 μ F ceramic capacitor is recommended between V_{IN} and GND pin to decouple input power supply glitch. This input capacitor must be located as close as possible to the device to assure input stability and reduce noise. For PCB layout, a wide copper trace is required for both V_{IN} and GND pin.

Enable Control

The AP7354 is turned on by setting the EN pin high, and is turned off by pulling them low. If this feature is not used, the EN pin should be tied to V_{IN} pin to keep the regulator output on at all time. To ensure proper operation, the signal source used to drive the EN pin must be able to swing above and below the specified turn-on/off voltage thresholds listed in the *Electrical Characteristics* section.

Layout Considerations

For good ground loop and stability, the input and output capacitors must be located close to the input, output, and GND pin of the device. The regulator GND pin must be connected to the external circuit ground to reduce voltage drop caused by trace impedance. Ground plane is generally used to reduce trace impedance. Wide trace must be used for large current paths from V_{IN} to V_{OUT} and load circuit.

ESR vs. Output Current

A ceramic type output capacitor is recommended for this series; however, the other output capacitors with low ESR also can be used. The relations between I_{OUT} (output current) and ESR of an output capacitor are shown below. The stable region is marked as the hatched area in the graph.

Measurement Conditions:

- Frequency Band: 10Hz to 2MHz
- Temperature: -40°C to +85°C

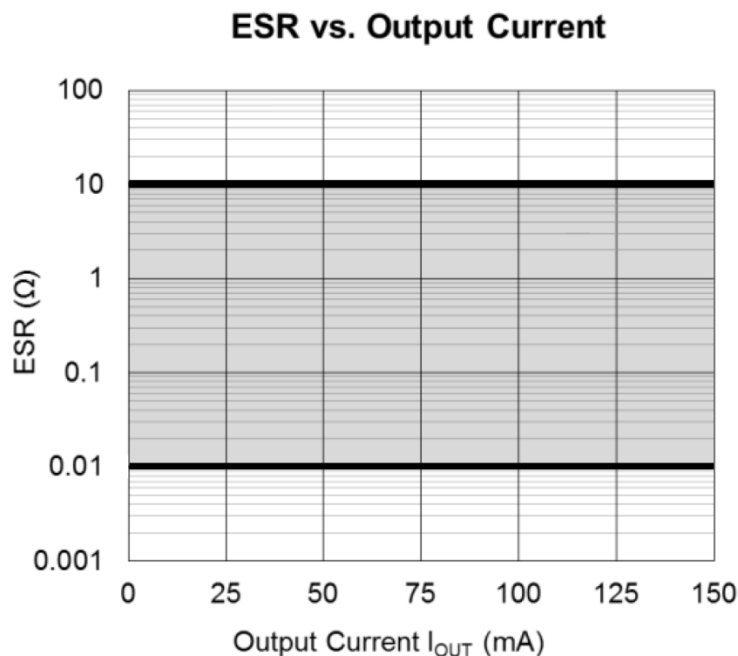

Ordering Information (Note 12)

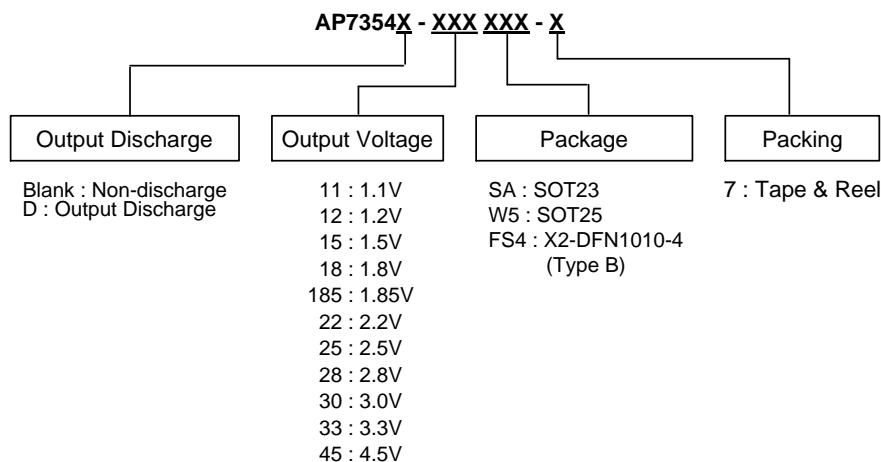

| Output Voltage | SOT23 | SOT25 Without Discharge | SOT25 With Discharge | 7" Tape and Reel | |
|----------------|----------------|----------------------------|-------------------------|------------------|--------------------|
| | | | | Quantity | Part Number Suffix |
| 1.2 | AP7354-12SA-7 | AP7354-12W5-7 | AP7354D-12W5-7 | 3000/Tape & Reel | -7 |
| 1.5 | AP7354-15SA-7 | AP7354-15W5-7 | AP7354D-15W5-7 | 3000/Tape & Reel | -7 |
| 1.8 | AP7354-18SA-7 | AP7354-18W5-7 | AP7354D-18W5-7 | 3000/Tape & Reel | -7 |
| 1.85 | AP7354-185SA-7 | AP7354-185W5-7 | AP7354D-185W5-7 | 3000/Tape & Reel | -7 |
| 2.2 | AP7354-22SA-7 | — | — | 3000/Tape & Reel | -7 |
| 2.5 | AP7354-25SA-7 | AP7354-25W5-7 | AP7354D-25W5-7 | 3000/Tape & Reel | -7 |
| 2.8 | AP7354-28SA-7 | AP7354-28W5-7 | AP7354D-28W5-7 | 3000/Tape & Reel | -7 |
| 3.0 | AP7354-30SA-7 | AP7354-30W5-7 | AP7354D-30W5-7 | 3000/Tape & Reel | -7 |
| 3.3 | AP7354-33SA-7 | AP7354-33W5-7 | AP7354D-33W5-7 | 3000/Tape & Reel | -7 |
| 4.5 | AP7354-45SA-7 | AP7354-45W5-7 | AP7354D-45W5-7 | 3000/Tape & Reel | -7 |

| Output Voltage | X2-DFN1010-4 (Type B) Without Discharge | X2-DFN1010-4 (Type B) With Discharge | 7" Tape and Reel | |
|----------------|--|---|------------------|--------------------|
| | | | Quantity | Part Number Suffix |
| 1.1 | AP7354-11FS4-7 | AP7354D-11FS4-7 | 5000/Tape & Reel | -7 |
| 1.2 | AP7354-12FS4-7 | AP7354D-12FS4-7 | 5000/Tape & Reel | -7 |
| 1.5 | AP7354-15FS4-7 | AP7354D-15FS4-7 | 5000/Tape & Reel | -7 |
| 1.8 | AP7354-18FS4-7 | AP7354D-18FS4-7 | 5000/Tape & Reel | -7 |
| 1.85 | AP7354-185FS4-7 | AP7354D-185FS4-7 | 5000/Tape & Reel | -7 |
| 2.5 | AP7354-25FS4-7 | AP7354D-25FS4-7 | 5000/Tape & Reel | -7 |
| 2.8 | AP7354-28FS4-7 | AP7354D-28FS4-7 | 5000/Tape & Reel | -7 |
| 3.0 | AP7354-30FS4-7 | AP7354D-30FS4-7 | 5000/Tape & Reel | -7 |
| 3.3 | AP7354-33FS4-7 | AP7354D-33FS4-7 | 5000/Tape & Reel | -7 |
| 4.5 | AP7354-45FS4-7 | AP7354D-45FS4-7 | 5000/Tape & Reel | -7 |

Note: 12. For packaging details, go to our website at <https://www.diodes.com/design/support/packaging/diodes-packaging/>.

Marking Information

(1) SOT23

(Top View)

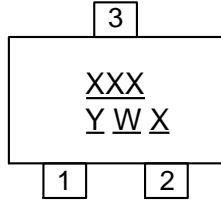

XXX : Identification Code
Y : Year 0 to 9
W : Week : A to Z : 1 to 26 week;
a to z : 27 to 52 week; z represents
52 and 53 week
X : Internal Code

| Part Number | Package | Identification Code |
|----------------|---------|---------------------|
| AP7354-12SA-7 | SOT23 | A8A |
| AP7354-15SA-7 | SOT23 | A8B |
| AP7354-18SA-7 | SOT23 | A8C |
| AP7354-185SA-7 | SOT23 | A8D |
| AP7354-22SA-7 | SOT23 | A8K |
| AP7354-25SA-7 | SOT23 | A8E |
| AP7354-28SA-7 | SOT23 | A8F |
| AP7354-30SA-7 | SOT23 | A8G |
| AP7354-33SA-7 | SOT23 | A8H |
| AP7354-45SA-7 | SOT23 | A8J |

Marking Information (continued)

(2) SOT25

(Top View)

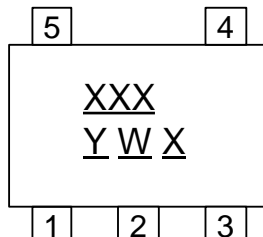

XXX : Identification Code

Y : Year 0 to 9

W : Week : A to Z : 1 to 26 week;
a to z : 27 to 52 week; z represents
52 and 53 week

X : Internal Code

| Part Number | Package | Identification Code |
|-----------------|---------|---------------------|
| AP7354-12W5-7 | SOT25 | A8A |
| AP7354-15W5-7 | SOT25 | A8B |
| AP7354-18W5-7 | SOT25 | A8C |
| AP7354-185W5-7 | SOT25 | A8D |
| AP7354-25W5-7 | SOT25 | A8E |
| AP7354-28W5-7 | SOT25 | A8F |
| AP7354-30W5-7 | SOT25 | A8G |
| AP7354-33W5-7 | SOT25 | A8H |
| AP7354-45W5-7 | SOT25 | A8J |
| AP7354D-12W5-7 | SOT25 | A9A |
| AP7354D-15W5-7 | SOT25 | A9B |
| AP7354D-18W5-7 | SOT25 | A9C |
| AP7354D-185W5-7 | SOT25 | A9D |
| AP7354D-25W5-7 | SOT25 | A9E |
| AP7354D-28W5-7 | SOT25 | A9F |
| AP7354D-30W5-7 | SOT25 | A9G |
| AP7354D-33W5-7 | SOT25 | A9H |
| AP7354D-45W5-7 | SOT25 | A9J |

Marking Information (continued)

(3) X2-DFN1010-4 (Type B)

(Top View)

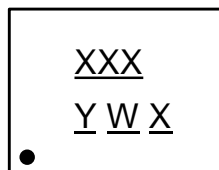

XXX : Identification Code

Y : Year : 0~9

W : Week : A~Z : 1~26 week;

a~z : 27~52 week; z represents
52 and 53 week

X : Internal Code

| Part Number | V _{OUT} | Package | Identification Code |
|------------------|------------------|-----------------------|---------------------|
| AP7354-11FS4-7 | 1.1V | X2-DFN1010-4 (Type B) | A8M |
| AP7354-12FS4-7 | 1.2V | X2-DFN1010-4 (Type B) | A8A |
| AP7354-15FS4-7 | 1.5V | X2-DFN1010-4 (Type B) | A8B |
| AP7354-18FS4-7 | 1.8V | X2-DFN1010-4 (Type B) | A8C |
| AP7354-185FS4-7 | 1.85V | X2-DFN1010-4 (Type B) | A8D |
| AP7354-25FS4-7 | 2.5V | X2-DFN1010-4 (Type B) | A8E |
| AP7354-28FS4-7 | 2.8V | X2-DFN1010-4 (Type B) | A8F |
| AP7354-30FS4-7 | 3.0V | X2-DFN1010-4 (Type B) | A8G |
| AP7354-33FS4-7 | 3.3V | X2-DFN1010-4 (Type B) | A8H |
| AP7354-45FS4-7 | 4.5V | X2-DFN1010-4 (Type B) | A8J |
| AP7354D-11FS4-7 | 1.1V | X2-DFN1010-4 (Type B) | A9M |
| AP7354D-12FS4-7 | 1.2V | X2-DFN1010-4 (Type B) | A9A |
| AP7354D-15FS4-7 | 1.5V | X2-DFN1010-4 (Type B) | A9B |
| AP7354D-18FS4-7 | 1.8V | X2-DFN1010-4 (Type B) | A9C |
| AP7354D-185FS4-7 | 1.85V | X2-DFN1010-4 (Type B) | A9D |
| AP7354D-25FS4-7 | 2.5V | X2-DFN1010-4 (Type B) | A9E |
| AP7354D-28FS4-7 | 2.8V | X2-DFN1010-4 (Type B) | A9F |
| AP7354D-30FS4-7 | 3.0V | X2-DFN1010-4 (Type B) | A9G |
| AP7354D-33FS4-7 | 3.3V | X2-DFN1010-4 (Type B) | A9H |
| AP7354D-45FS4-7 | 4.5V | X2-DFN1010-4 (Type B) | A9J |

Package Outline Dimensions

Please see <http://www.diodes.com/package-outlines.html> for the latest version.

(1) Package Type: SOT23

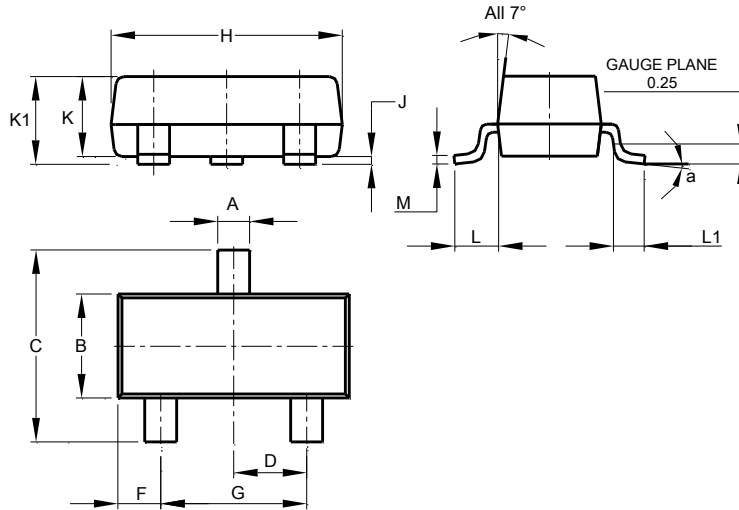

| SOT23 | | | |
|----------------------|-------|-------|-------|
| Dim | Min | Max | Typ |
| A | 0.37 | 0.51 | 0.40 |
| B | 1.20 | 1.40 | 1.30 |
| C | 2.30 | 2.50 | 2.40 |
| D | 0.89 | 1.03 | 0.915 |
| F | 0.45 | 0.60 | 0.535 |
| G | 1.78 | 2.05 | 1.83 |
| H | 2.80 | 3.00 | 2.90 |
| J | 0.013 | 0.10 | 0.05 |
| K | 0.890 | 1.00 | 0.975 |
| K1 | 0.903 | 1.10 | 1.025 |
| L | 0.45 | 0.61 | 0.55 |
| L1 | 0.25 | 0.55 | 0.40 |
| M | 0.085 | 0.150 | 0.110 |
| a | 0° | 8° | -- |
| All Dimensions in mm | | | |

(2) Package Type: SOT25

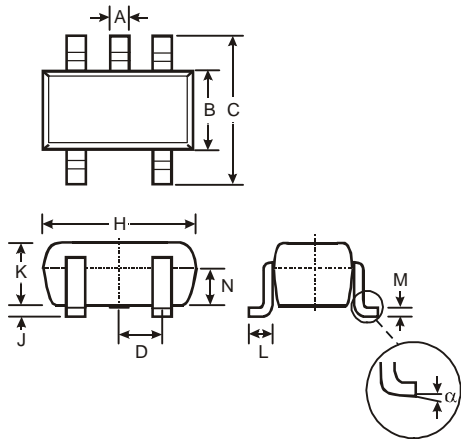

| SOT25 | | | |
|----------------------|-------|------|------|
| Dim | Min | Max | Typ |
| A | 0.35 | 0.50 | 0.38 |
| B | 1.50 | 1.70 | 1.60 |
| C | 2.70 | 3.00 | 2.80 |
| D | - | - | 0.95 |
| H | 2.90 | 3.10 | 3.00 |
| J | 0.013 | 0.10 | 0.05 |
| K | 1.00 | 1.30 | 1.10 |
| L | 0.35 | 0.55 | 0.40 |
| M | 0.10 | 0.20 | 0.15 |
| N | 0.70 | 0.80 | 0.75 |
| α | 0° | 8° | - |
| All Dimensions in mm | | | |

Package Outline Dimensions (continued)

Please see <http://www.diodes.com/package-outlines.html> for the latest version.

(3) Package Type: X2-DFN1010-4 (Type B)

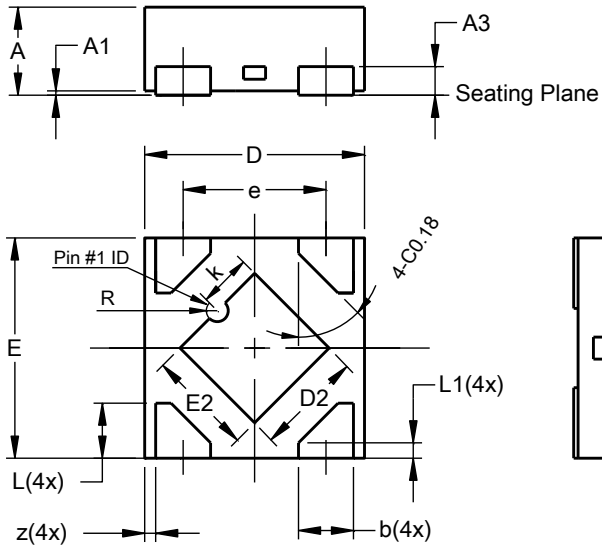

| X2-DFN1010-4 (Type B) | | | |
|-----------------------|------|------|-------|
| Dim | Min | Max | Typ |
| A | - | 0.40 | 0.39 |
| A1 | 0.00 | 0.05 | 0.02 |
| A3 | - | - | 0.13 |
| b | 0.20 | 0.30 | 0.25 |
| D | 0.95 | 1.05 | 1.00 |
| D2 | 0.43 | 0.53 | 0.48 |
| E | 0.95 | 1.05 | 1.00 |
| E2 | 0.43 | 0.53 | 0.48 |
| e | - | - | 0.65 |
| k | 0.19 | 0.29 | 0.24 |
| L | 0.20 | 0.30 | 0.25 |
| L1 | 0.02 | 0.12 | 0.07 |
| R | 0.02 | 0.08 | 0.05 |
| z | - | - | 0.050 |
| All Dimensions in mm | | | |

Suggested Pad Layout

Please see <http://www.diodes.com/package-outlines.html> for the latest version.

(1) Package Type: SOT23

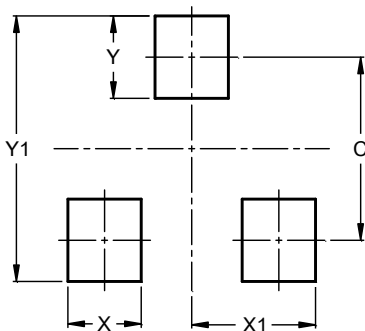

| Dimensions | Value (in mm) |
|------------|---------------|
| C | 2.0 |
| X | 0.8 |
| X1 | 1.35 |
| Y | 0.9 |
| Y1 | 2.9 |

(2) Package Type: SOT25

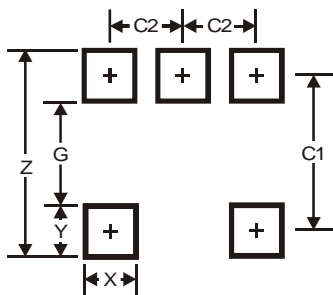

| Dimensions | Value |
|------------|-------|
| Z | 3.20 |
| G | 1.60 |
| X | 0.55 |
| Y | 0.80 |
| C1 | 2.40 |
| C2 | 0.95 |

Suggested Pad Layout (continued)

Please see <http://www.diodes.com/package-outlines.html> for the latest version.

(3) Package Type: X2-DFN1010-4 (Type B)

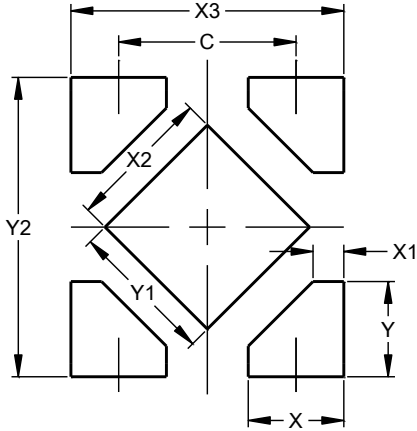

| Dimensions | Value (in mm) |
|------------|---------------|
| C | 0.650 |
| X | 0.350 |
| X1 | 0.112 |
| X2 | 0.530 |
| X3 | 1.00 |
| Y | 0.350 |
| Y1 | 0.530 |
| Y2 | 1.100 |