

868MHz; 25 x 25 x 4mm RFID(EU) Patch Antenna



25.0 x 25.0 x 4.0mm

APAE868R2540JBDB2-T

RoHS/ RoHS II compliant

MSL level: Not Applicable

FEATURES:

- Compact size
- RoHS Compliance

TYPICAL APPLICATIONS:

RFID systems for Logistic & Inventory Management of Retail, Pharmaceutical, Automotive Industries; Industrial automation, Contactless smart cards.

STANDARD SPECIFICATIONS:

Parameters	Min.	Typ.	Max.	Units	Note
Nominal Frequency		868.0		MHz	
Center Frequency @ -10dB bandwidth ^(*)		868.0±2.0		MHz	(Without adhesive tape on 70x70mm ground plane)
-10dB bandwidth	2.5			MHz	
Gain (at Zenith 90°)		-1.37		dBic	(Peak gain on standard 70x70mm Ground Plane.)
VSWR at Center Frequency			1.5		
Polarization Model	RHCP				(Right Hand Circular Polarization)
Impedance	50			Ω	
Frequency Temperature Coefficient			20	ppm/°C	

^(*)Application environment, including size of ground plane will affect stated performance. Fine tuning might be required when installed on customer's PCB.

TEST CONDITIONS & TEST SETUP:

Parts shall be measured under a condition
(Temp.: 20±15°C, Humidity: 65±20% R.H.)

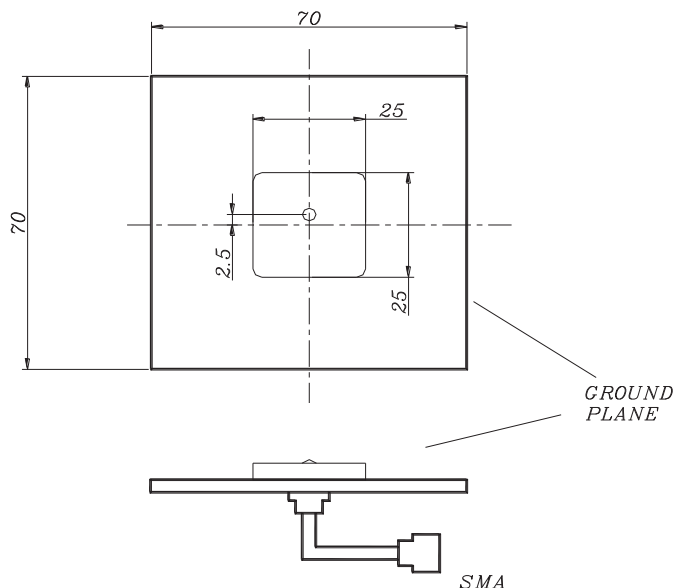

RADIATION PATTERN

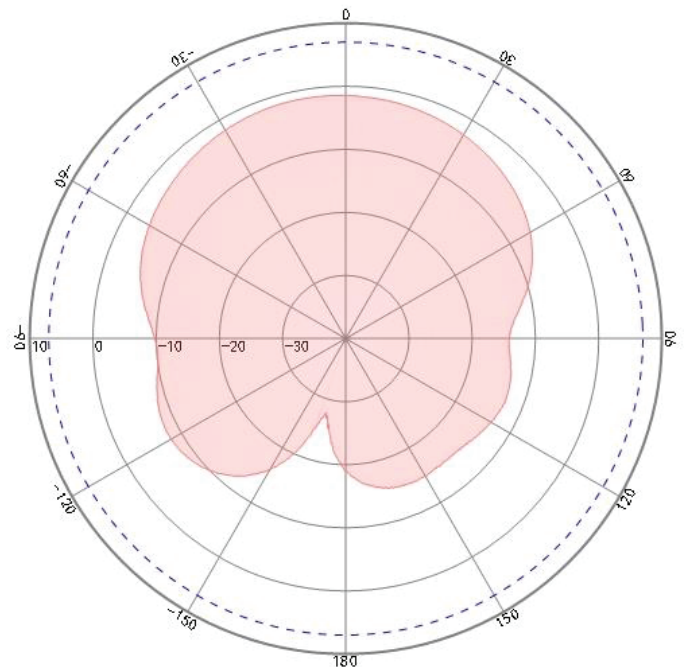

868MHz; 25 x 25 x 4mm RFID(EU) Patch Antenna

APAE868R2540JBDB2-T

RoHS/ RoHS II compliant



25.0 x 25.0 x 4.0mm

IMPEDANCE CHARACTERISTICS

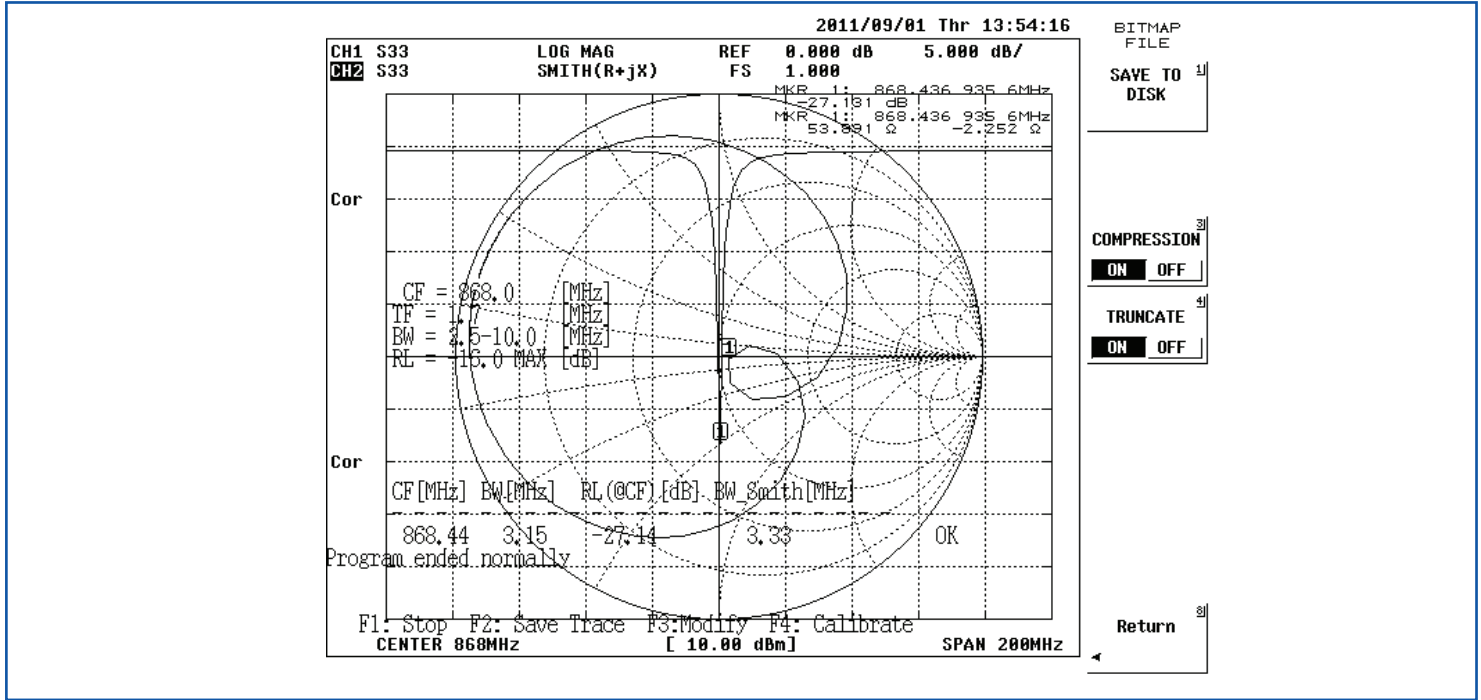

OUTLINE DRAWING:

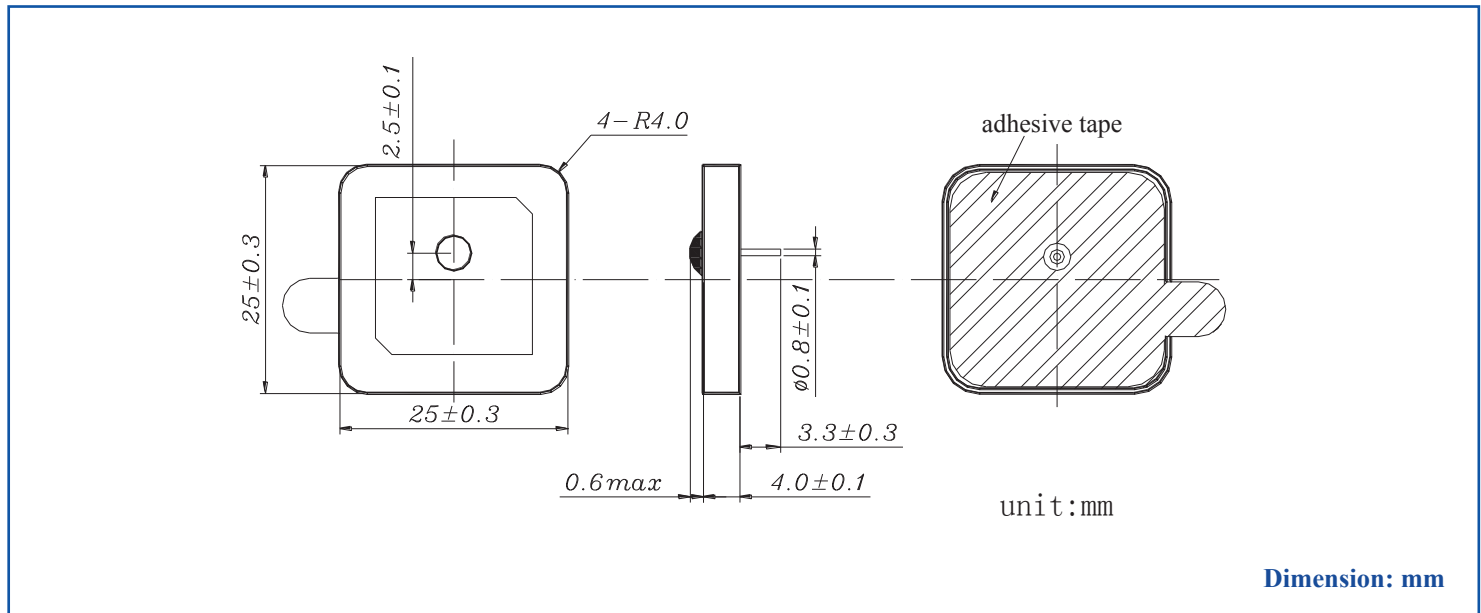

868MHz; 25 x 25 x 4mm RFID(EU) Patch Antenna

APAE868R2540JBDB2-T

RoHS/ RoHS II compliant



25.0 x 25.0 x 4.0mm

PACKAGING:

“T” is for a vacuum sealed tray containing 50 units.

1000 pieces is the suggested quantity containing 20-trays with 50-pcs per Tray.

NOTE: Recommend vacuum storage under normal temperature and dry conditions, valid for 12 months after production is completed.

- Normal temperature: 25°C
- Humidity: 40%

If the package is taken apart, the patch surface is exposed to moisture and gets oxidized. The rate of oxidation is dependent on the environmental conditions.

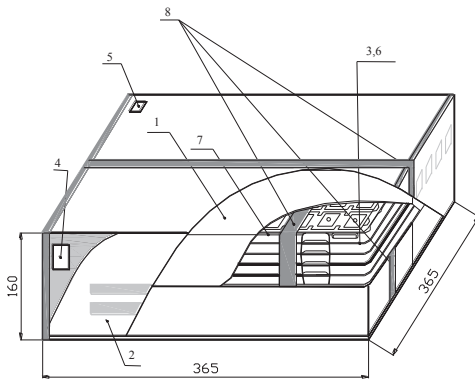

Inner Box dimensions (unit: mm)

NO.	Name
1	Inner Box
2	Package
3	Vacuum Bag
4	Certificate of approval
5	Label
6	Cushion
7	Tray
8	Adhesive tape

