



APC1

Air Purification Combo ONE

APC1 datasheet

Version: 1.0

Release Date: 2022-04-11

Document Status: Production

The APC1 is a compact, box-shaped, all-in-one environmental sensor solution to precisely measure particulate matter and aerosols, volatile organic compounds, temperature and humidity. It leverages the SciSense leading edge sensor technology to provide an accurate, fully calibrated, maintenance-free solution to air quality monitoring.

For maximum flexibility, the APC1 provides up to 20 environmental signal parameters through UART and I²C interfaces. Moreover, it features temperature compensation algorithms to simplify integration on system level, thereby accelerating time to market at minimal overall BOM costs.

The APC1 is a proven, maintenance-free technology, designed for high volumes and reliability.

Key Features & Benefits

Calibrated signal outputs in compliance with international standards (PM1.0, PM2.5, PM10, TVOC, eCO₂¹, AQI², temperature and relative humidity).

Matchbox-size, fully orchestrated design for space-constrained applications and lowest overall BOM costs.

System level temperature compensation to expedite integration on system level and time to market.

Particle detection down to 0.3µm

Superior accuracies over wide temperature and humidity ranges

- Temperature
 - Accuracy: ±0.45°C, typ.
 - Range: 5 to 50°C
- Humidity
 - Accuracy: ±4%RH, typ.
 - Range: 10 to 95%RH

Applications

- **Home appliances**
 - Air cleaners / purifiers
- **Building Automation / smart home / HVAC³**
 - Indoor air quality detection
 - Demand-controlled ventilation
 - Smart thermostats
- **IoT devices & air quality monitors**

Properties

Supply voltage: 4.5 to 5.5V

UART or I²C with 3.3V communication interface

Power consumption: 75mA

Short response times

- Temperature T₆₃: <60s
- Humidity T₆₃: <18s

Smallest footprint: 50 x 38 x 21mm

¹ eCO₂ = equivalent CO₂ values for compatibility with HVAC ventilation standards

² AQI = Air Quality Index

³ HVAC = Heat, Ventilation and Air Conditioning

Table of Contents

Key Features & Benefits.....	2	12 RoHS Compliance & SciSense Green Statement	24
Applications.....	2	13 Copyrights & Disclaimer.....	24
Properties	2	14 Document status	25
Table of Contents	3	15 Revision information	25
1 Block diagram	4		
2 Absolute maximum ratings	4		
3 Intended use	5		
4 Functional component specifications	5		
4.1 General.....	5		
4.2 Environmental Conditions	5		
4.3 Sensor specifications	6		
4.3.1 Temperature and humidity.....	6		
4.3.2 Particulate matter.....	7		
4.3.3 VOC	8		
5 Electrical specifications.....	9		
6 Hardware interface specifications	10		
7 Host communication	11		
7.1 Application circuitry.....	11		
7.2 UART interface	12		
7.3 Operating modes.....	13		
7.4 UART Communication	14		
7.4.1 Commands	14		
7.4.2 64-byte output structure	15		
7.4.3 Error codes	16		
7.4.4 Example commands and operation.....	17		
8 Integration and operation	19		
8.1 General.....	19		
8.2 Combo orientation.....	19		
8.3 Integration into a host system	20		
8.3.1 Mechanical Integration	20		
8.3.2 Temperature and humidity compensation on system level	20		
9 Package drawings & markings.....	22		
10 Ordering information	23		
11 Shipment & Packaging.....	23		

1 Block diagram

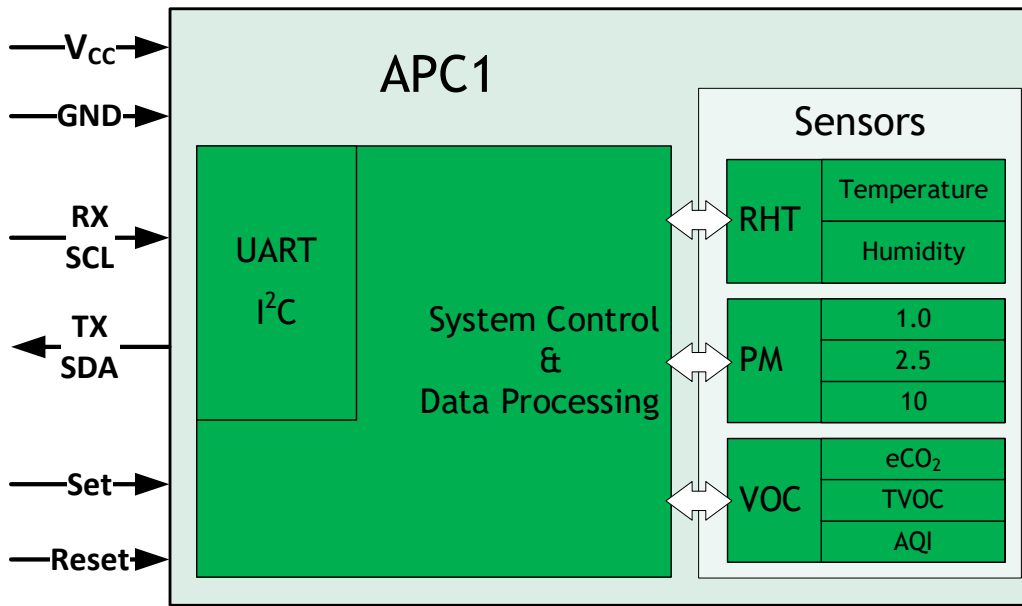

Figure 1: Functional Blocks

The APC1 combo module comprises of a temperature and humidity sensor, a multi-particulate matter (PM) sensor and a VOC sensor, providing standardized signal outputs. Equipped with an internal fan and a control CPU, the APC1 autonomously controls the sensor functionality, including full temperature compensation and output via UART or I²C interface.

2 Absolute maximum ratings

Table 1: Absolute Maximum Ratings

Symbol	Parameter	Min	Typ	Max	Unit	Comments
Environmental Operating & Storage Conditions						
See Table 3						
Electrical Parameters						
V _{DD}	Supply Voltage	-0.3	5.0	6.0	V	
V _{IO}	I/O pins	-0.3		5.5	V	
I _{IO}	Max. current per I/O pin	-18		20	mA	
See Table 7 for further information						

Exposure of the APC1 to conditions outside these ranges may result in reduced performance and accuracy or even permanently damage the APC1. Prolonged operation at these limits can lead to reduced lifetime.

3 Intended use

The APC1 sensor combo is intended for use in common indoor environments. It shall be operated in normal indoor air within its specified, non-condensing environmental conditions, with no aggressive or poisonous gases present. Prolonged exposure to environments outside these conditions can affect performance and lifetime of the sensor.

The APC1 is not designed for use in safety-critical or life-protecting applications.

4 Functional component specifications

4.1 General

Table 2: Module specifications⁴

Parameter	Conditions	Value	Unit
Output data rate		1	Hz
Noise Level ⁵	0.2m distance	24	dB(A)
Noise Level long-term drift	0.2m distance	0.5	dB(A)/a
Lifetime	25 °C; 50% RH	10	years
Physical Size		50 × 38 × 21	mm
Weight		36	g

4.2 Environmental Conditions

Table 3: Operating & Storage Conditions

Symbol	Parameter	Min	Typ	Max	Unit	Comments
T _{AMB}	Operating Ambient Temperature	5		50	°C	
RH _{AMB}	Operating Ambient Rel. Humidity	10		95	%	Non-condensing
T _{STRG}	Storage Temperature	10		50	°C	
RH _{STRG}	Storage Relative Humidity	20		60	%	Non-condensing

⁴ Default combo conditions in standard measurement mode: 24 °C and 5 V supply voltage, unless stated otherwise.

⁵ Measured indoors @ background noise <17dB(A).

4.3 Sensor specifications

4.3.1 Temperature and humidity

The APC1 deploys a highly accurate capacitive humidity and temperature sensor.

Table 4: Temperature and humidity sensor specifications

Parameter	Conditions	Min	Typ	Max	Unit
Temperature					
Range	@50%RH	5	25	50	°C
Accuracy	@50%RH		0.45	0.7	°C
Resolution			0.1		°C
Repeatability	@50%RH and 24°C			0.05	°C
Response Time T ₆₃	T-step from 23 to 45°C @50%RH			<60	s
Relative Humidity					
Range	@24°C	10	50	95	%RH
Accuracy	@24°C and 25 to 75%RH		4	6	%RH
Resolution			0.1		%RH
Repeatability	@24°C and 25 to 75%RH			0.75	%RH
Response Time T ₆₃	RH step from 40% to 60% @24°C			<18	s

4.3.2 Particulate matter

The APC1 uses proven laser scattering technology to reliably detect particles down to 0.3 μm .

Table 5: Particulate matter sensor specifications

Parameter	Condition	Value	Unit
Size ranges	PM1.0	0.3 - 1.0	μm
	PM2.5	0.3 - 2.5	μm
	PM10	0.3 - 10	μm
Resolution		1	$\mu\text{g}/\text{m}^3$
Standard volume		0.1	L
Effective concentration range	PM2.5	0 – 500	$\mu\text{g}/\text{m}^3$
	PM10	0 – 500	$\mu\text{g}/\text{m}^3$
Maximum Upper Limit of Range	PM2.5	≥ 1000	$\mu\text{g}/\text{m}^3$
	PM10	≥ 1500	$\mu\text{g}/\text{m}^3$
Maximum Consistency Error	PM2.5 100 – 1000 $\mu\text{g}/\text{m}^3$ 0 – 100 $\mu\text{g}/\text{m}^3$	± 10	%
		± 10	$\mu\text{g}/\text{m}^3$
	PM10 100 – 1000 $\mu\text{g}/\text{m}^3$ 0 – 100 $\mu\text{g}/\text{m}^3$	± 15	%
		± 15	$\mu\text{g}/\text{m}^3$
Counting Efficiency	@ 0.3 μm	50	%
	$\geq 0.5 \mu\text{m}$	98	%
Laser Wavelength		650	nm
Laser Class	DIN EN 60825-1	1	
Start-Up Time ⁶	typical	30	s

⁶ Determined by fan rev up after powering.

4.3.3 VOC

The APC1 deploys a multi-gas sensor solution based on metal-oxide (MOX) technology. Outputs are provided in standard TVOC or eCO₂ concentrations or as AQI values⁷.

Table 6: VOC sensor specifications

Parameter	Description		Min	Typ	Max	Unit
Output Signals	TVOC	Total VOC concentration	0		65,000	ppb
	eCO ₂	Equivalent CO ₂	400		65,000	ppm CO ₂ -equiv.
	AQI-UBA ⁸	Air Quality Index	1		5	-
Start-Up Time ⁹	Initial Start-Up	After first power up		60		min
	Warm-Up	After every power up		3		min

⁷ TVOC = Total Volatile Organic Compounds; eCO₂ = equivalent CO₂; AQI = Air Quality Index

⁸ Classified TVOC output signal according to the indoor air quality levels by the German Federal Environmental Agency (UBA, 2007).

⁹ Device is not designed for power-cycling.

5 Electrical specifications

Table 7: Electrical specifications

Symbol	Parameter	Min	Typ	Max	Unit	Comments
V _{DD}	Supply Voltage	4.5	5.0	5.5	V	
I _{Op}	Operating Current	-	75	≤120 ¹⁰	mA	Active measurement & fan
I _{Idle}	Idle Current	-	9	≤10	mA	Idle mode
I _{DeepSleep}	Deep Sleep Current	-	1.7	≤2	mA	Deep Sleep mode (via SET pin)
V _{IH}	I/O Input HIGH level voltage	2.7			V	@ 3.3V
V _{IL}	I/O Input LOW level voltage			0.6	V	@ 3.3V

Default combo conditions in standard measurement mode: 24 °C and normal ambient air, unless stated otherwise.

Table 8: ESD / EMC ratings

		Electrostatic Discharge			
ESD _{HBM}	Electrostatic Discharge HBM	±2,000		V	JS-001-2014

¹⁰ Only during short / extreme conditions e.g. start-up of fan.

6 Hardware interface specifications

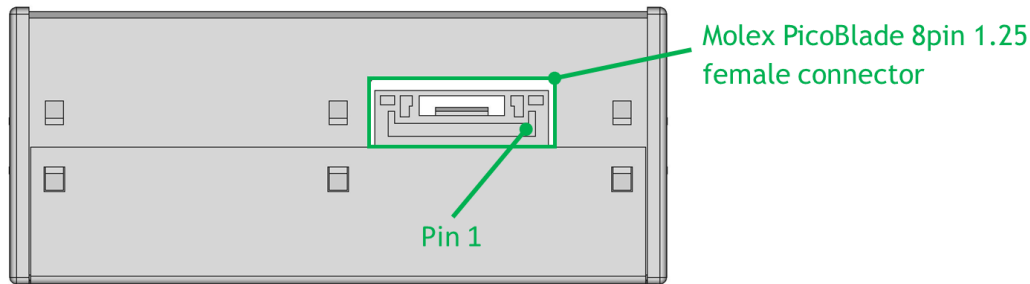

Figure 2: Connector type and pin orientation on device

Table 9: Pin assignment

Pin ID	Pin Name	Pin Type	Description
1	V _{DD}	Supply	5V (Supply voltage)
2	GND	Supply	Ground
3	SET	Input	LOW: Deep Sleep mode. HIGH or floating: resume previous operating mode (Idle or Measurement mode). Internally pulled-up.
4	UART_RX / I2C_SCL	Input	UART RX or I ² C SCL. Internally pulled-up.
5	UART_TX / I2C_SDA	Output	UART TX or I ² C SDA. Internally pulled-up.
6	RESET	Input	Set LOW to Reset device. Internally pulled-up.
7	NC		Internal use only. Do not connect.
8	NC		Internal use only. Do not connect.

7 Host communication

7.1 Application circuitry

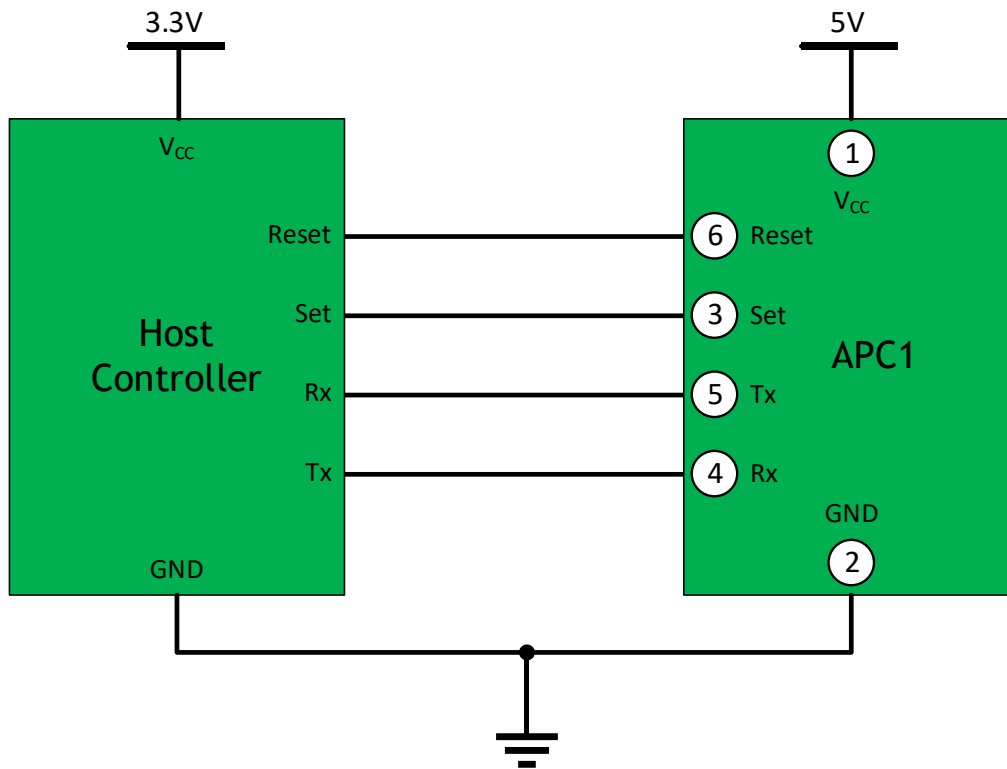

Figure 3: Recommended application circuitry

Note(s):

- While a 5V DC supply voltage is required to drive the fan, the communication interfaces run at 3.3V TTL level.
- Pins 3, 4, 5, 6 are pulled-up internally
- Do not connect SET (pin 3) and RESET (pin 6) when not used.
- Do not connect pins 7 and 8.
- The outer metal shell is connected to GND.
Do not connect to any other live component or parts of circuitry except GND.
- Do not remove the outer metal shell of the APC1.
- Do not open the module.

7.2 UART interface

The Universal Asynchronous Receiver/Transmitter (UART) protocol is an asynchronous serial interface.

UART communication between the APC1 and a host system is based on transmitter (Tx) and receiver (Rx) connected to the host system as depicted in Figure 3 with the following settings:

Table 10: APC1 UART communication settings

Parameter	Value	Unit	Description
Baud rate	9,600	bit/s	-
Data bits	8	bit	-
Parity	None	-	-
Stop bit	1	bit	-

The data byte structure looks as follows:

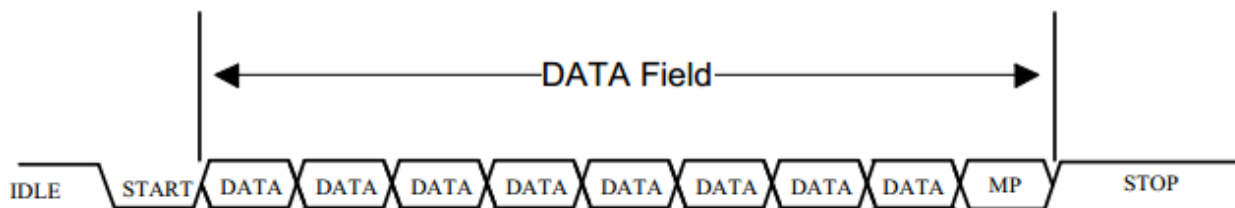

Figure 4: APC1 data byte structure

7.3 Operating modes

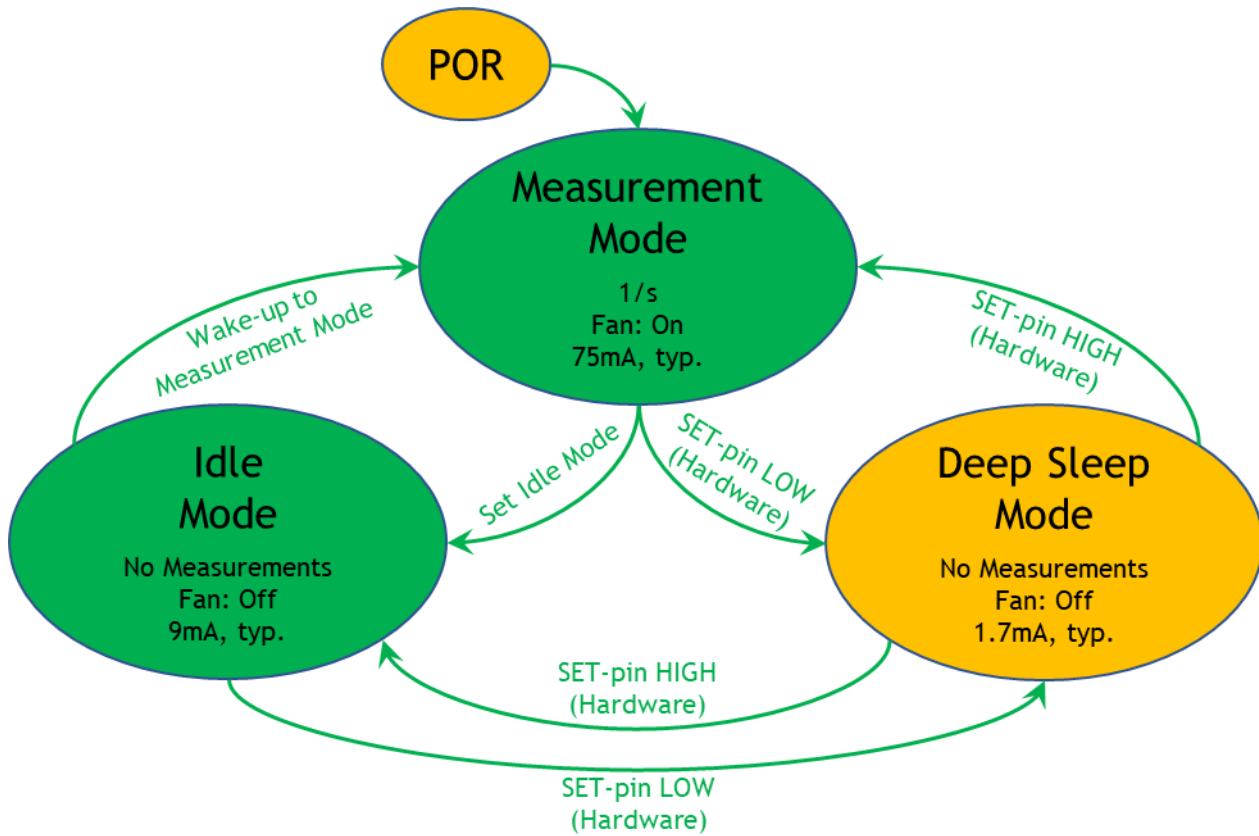

Figure 5: Operating Modes

After Power-on (POR) the APC1 enters its default operating mode: Measurement Mode, carrying out a new set of measurement data every second. See section 7.4.4.1 on how to obtain measurement data from the device).

For power savings and to stop the fan, the device can be set to Idle Mode (see section 7.4.4.2). Moreover, it can be put into Deep Sleep by hardware (see section 7.4.4.4). No measurements or measurement data can be executed or obtained in Idle or Deep Sleep Mode.

7.4 UART Communication

7.4.1 Commands

The APC1 requires the following command protocol:

Table 11: Host to device command structure

StartByte1	StartByte2	Command	ModeH	ModeL	ChecksumH	ChecksumL
0x42	0x4D	Command	ModeH	ModeL	LRCH	LRCL

The following commands are available:

Table 12: APC1 host commands

Command	ModeH	ModeL	Description
0xE1	X	0x00 Set passive mode 0x01 Set active mode	Toggle meas. result communication mode: Passive: Device to send 64-byte structure on request (Default). Active: Device to send 64-byte structure every second
0xE2	X	0x00 Request new meas. data	Once in passive mode, this command requests the device to send a 64-byte data structure containing the latest measurement results.
0xE4	X	0x00 Set to Idle mode 0x01 Wake-up to Meas. mode	Toggle between Idle and Measurement mode (Default).

After successful execution of a command, the APC1 answers within 200ms with the following protocol:

Table 13: Device to host answer protocol structure

StartByte1	StartByte2	FrameLengthH	FrameLengthL	Command	Data	ChecksumH	ChecksumL
0x42	0x4d	0x00	FrameLengthL	Command or Data	ModeL or Data	LRCH	LRCL

The **Checksum** is the sum of the values of all bytes sent, not considering the Checksum itself, with

- ChecksumH = LRCH = High byte
- ChecksumL = LRCL = Low byte

This is valid for both, host-to-device and device-to host communication.

7.4.2 64-byte output structure

When in Measurement mode, the following structure of measurement data is provided and updated every second.

Table 14: Output registers

Addr	Field Name	Size (byte)	Range		Resolution	Unit	Access (R/W)	Description
			Data	Physical				
0x00	Frame header	2	0x42 0x4D	-	-	-	R	Frame header
0x02	Frame length	2	0x00 0x3C	-	-	-	R	Frame length (60 byte)
0x04	PM1.0	2	0-500	0-500	1	ug/m3	R	PM1.0 mass concentration
0x06	PM2.5	2	0-1,000	0-1,000	1	ug/m3	R	PM2.5 mass concentration
0x08	PM10	2	0-1,500	0-1,500	1	ug/m3	R	PM10 mass concentration
0x0A	PM1.0 in air	2	0-500	0-500	1	ug/m3	R	PM1.0 mass concentration in atmospheric environment
0x0C	PM2.5 in air	2	0-1,000	0-1,000	1	ug/m3	R	PM2.5 mass concentration in atmospheric environment
0x0E	PM10 in air	2	0-1,500	0-1,500	1	ug/m3	R	PM10 mass concentration atmospheric environment
0x10	# particles >0.3µm	2	0-65,535	0-65,535	1	Particle count	R	Number of particles with diameter > 0.3µm in 0.1L of air
0x12	# particles >0.5µm	2	0-65,535	0-65,535	1	Particle count	R	Number of particles with diameter > 0.5µm in 0.1L of air. To determine # of PM0.5 particles subtract field 0x12 from field 0x10.
0x14	# particles >1.0µm	2	0-65,535	0-65,535	1	Particle count	R	Number of particles with diameter > 1.0µm in 0.1L of air. To determine # of PM1.0 particles subtract field 0x14 from field 0x10.
0x16	# particles >2.5µm	2	0-65,535	0-65,535	1	Particle count	R	Number of particles with diameter > 2.5µm in 0.1L of air. To determine # of PM2.5 particles subtract field 0x16 from field 0x10.
0x18	# particles >5.0µm	2	0-65,535	0-65,535	1	Particle count	R	Number of particles with diameter > 5.0µm in 0.1L of air. To determine # of PM5 particles subtract field 0x18 from field 0x10.
0x1A	# particles >10µm	2	0-65,535	0-65,535	1	Particle count	R	Number of particles with diameter > 10µm in 0.1L of air. To determine # of PM10 particles subtract field 0x1A from field 0x10.
0x1C	TVOC	2	0-65,000	0-65,000	1	ppb	R	TVOC output
0x1E	eCO ₂	2	400-65,000	400-65,000	1	ppm	R	Output in ppm CO ₂ equivalents
0x20	Reserved	2	-	-	-	-	-	Reserved

Addr	Field Name	Size (byte)	Range		Resolution	Unit	Access (R/W)	Description
			Data	Physical				
0x22	T-comp.	2	0-500	0-50	0.1	°C	R	Compensation only valid for detached module operation according to orientation 4 (figure 6). See section 8.3.2 for temperature and humidity compensation on system level.
0x24	RH-comp.	2	0-1,000	0-100	0.1	%	R	
0x26	T-raw	2	0-500	0-50	0.1	°C	R	Uncompensated temperature
0x28	RH-raw	2	0-1,000	0-100	0.1	%	R	Uncompensated humidity
0x2A	RS ₀	4	100 - 50M	(100) 1k - 10M (50M)	1	Ω	R	Gas sensor raw resistance value RS _i . (RS ₁ not used) Values show specified range. Values in brackets show total / measurement range.
0x2E	RS ₁	4						
0x32	RS ₂	4						
0x36	RS ₃	4						
0x3A	AQI	1	1-5	1-5	1	-	R	Air Quality Index according to UBA
0x3B	Reserved	1	-	-	-	-	-	Reserved
0x3C	Version	1	-	-	-	-	R	Firmware version
0x3D	Error code	1	-	-	-	-	R	See section 7.4.3
0x3E	Checksum	2	-	-	-	-	R	Frame (0x00 – 0x3D) checksum
Total bytes:		64						

Notes: First byte: MSB; last byte: LSB; valid for all multi-byte data of 64-byte output structure.

7.4.3 Error codes

Table 15: Error codes

Bit7	Bit6	Bit5	Bit4	Bit3	Bit2	Bit1	Bit0
X	X	X	X	Fan start-up error	X	Fan-speed too low	Too many Fan restarts

No error: error code = 0x00 (= default error code)

7.4.4 Example commands and operation

7.4.4.1 Read measurement data from device

This command requests the APC1 to send the latest set of measurement results (64-byte structure).

Make sure the device is in Measurement mode with passive communication (Default after POR).

Send the following protocol:

Table 16: Communication protocol to request the latest set of measurement results

Host command	0x42 0x4D 0xE2 0x00 0x00 0x01 0x71
Device answer	0x42 0x4D FrameLengthH/L PM1.0H/L PM2.5H/L ... Version ErrorCode ChecksumH/L

The device responds by sending a 64-byte structure (see “Device answer”) containing the latest measurement results.

Repeat this command whenever there is a need for new measurement data. Note that the maximum update rate of the 64-byte structure is 1Hz.

7.4.4.2 Set Idle mode

This command sets the device to Idle mode, resulting in:

- No measurements
- No updates of the 64-byte output register structure
- Fan: Off
- Low power consumption: 9mA

Table 17: Communication protocol to set APC1 to Idle Mode

Host command	0x42 0x4D 0xE4 0x00 0x00 0x01 0x73
Device answer	0x42 0x4D 0x00 0x04 0xE4 0x00 0x01 0x77

7.4.4.3 Set Measurement mode

This command (re-)sets the device from Idle to measurement mode (default after POR), resulting in:

- Active measurements
- Fan: On

- Average power consumption: 75mA

Table 18: Communication protocol to set APC1 to Measurement Mode

Host	0x42 0x4D 0xE4 0x00 0x01 0x01 0x74
Device	0x42 0x4D 0x00 0x04 0xE4 0x01 0x01 0x78

7.4.4.4 Set Deep Sleep mode

The power-saving Deep Sleep mode can be invoked using hardware pin 3 (SET). It can be set at any operating mode (Idle or Measurement mode) by putting the SET pin to LOW (GND), resulting in:

- No measurements
- No updates of the 64-byte output register structure
- Fan: Off
- Lowest power consumption: 1.7mA

To resume the previous operating mode (Idle or Measurement), put the SET pin HIGH again.

8 Integration and operation

8.1 General

- Do not remove the outer metal shell of the APC1.
- Do not attempt to open the module.
- Protection must be added if the sensor is used in the following conditions:
 - PM concentrations $\geq 300\mu\text{g}/\text{m}^3$ for more than 50% of combo lifetime
 - PM concentrations $\geq 500\mu\text{g}/\text{m}^3$ for more than 20% of combo lifetime
 - Kitchen environment
 - Occasional water mist conditions such as in bathroom environments.
- Refer to section 3 “Intended use” for further details.

8.2 Combo orientation

To ensure proper functioning throughout the entire lifetime, the following guidelines for combo orientation must be met:

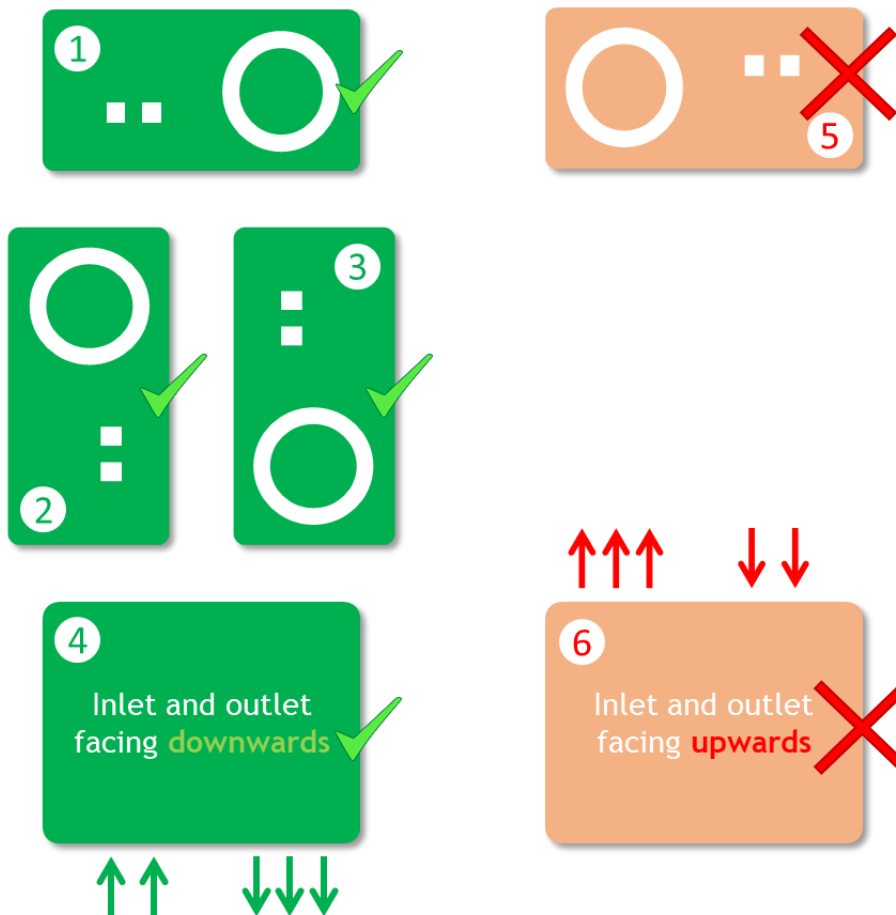

Figure 6: Recommended combo orientation

8.3 Integration into a host system

8.3.1 Mechanical Integration

- Keep inlet and outlet plane of both, APC1 and host system as close as possible to each other. If required, use suitable air guides and/or ductwork with sealants to avoid short-circuits of air flows.
- Host system inlet and outlet must not be smaller than APC1 inlet and outlet.
- To avoid false results, protect/shield inlet and outlet from output air flow of ventilation system or air cleaner.
- Install APC1 at least 20 cm above the floor in order to prevent blocking by larger particles or flock dust.

8.3.2 Temperature and humidity compensation on system level

For precise temperature and humidity readings, the APC1 is equipped with a temperature and humidity compensation algorithm on module level. Due to excess heat from external/host components, some integrations require further temperature and humidity compensation.

This section describes how to determine and compensate such offsets and correct for consequential humidity errors.

8.3.2.1 Determining and compensating the temperature offset

The following procedure uses a single temperature measurement point to determine the APC1 temperature offset, induced by a host system.

Required items:

- A temperature reference T_{Ref} (e.g. SciSense ENS210 evaluation kit on flex-foil).
- A system with an integrated APC1, logging the device's temperature reading T_{Sys} . **Important Note:** As the device's temperature reading T_{Sys} , it is recommended to use the compensated temperature value T_{comp} from the 64-byte data structure (see [Table 14](#), Register 0x22). Do not use T_{raw} .

T compensation equation:

$$T_{Ref} = T_{Sys} + T_{Offset}$$

Compensation procedure:

1. Setup the temperature reference and system under calibration in a *thermally stable* environment at a typical environmental / operating temperature.
2. Wait for the temperature readings to stabilize (APC1 and reference); thereafter start recording.

Note: For the sake of highest accuracy, it is advisable to carry out a series of experiments and/or log the data for a longer duration while stable.

- For highest precision, average the recorded temperature values before calculating the difference between system and reference with the following equation:

$$\Delta T = T_{Offset} = T_{Ref} - T_{Sys}$$

with

T_{Ref} : Averaged temperature value of the temperature reference

T_{Sys} : Averaged temperature value of the system under calibration

- Compensate the temperature reading by subtracting the determined offset:

$$T_{Comp} = T_{Sys} + T_{Offset} = T_{Sys} + (T_{Ref} - T_{Sys})$$

Example T-Compensation

Assuming the above experiment shows the following results:

$$T_{Ref} = 21^{\circ}C; T_{Sys} = 25^{\circ}C \rightarrow \Delta T = T_{Offset} = T_{Ref} - T_{Sys} = -4^{\circ}C$$

Meaning that the host system causes a temperature offset of an additional 4°C on the APC1, which needs to be compensated for by subtracting said 4°C from the APC1's T_{Sys} reading:

$$T_{Comp} = T_{Sys} + T_{Offset} = T_{Sys} + (T_{Ref} - T_{Sys}) = 25^{\circ}C + (21^{\circ}C - 25^{\circ}C) = 21^{\circ}C$$

8.3.2.2 Correcting the temperature-offset induced humidity error

Since (per definition) the relative humidity output is a temperature-dependent signal, it requires a temperature-offset-dependent correction, provided the temperature offset is other than zero.

Once the T-compensation is done, the humidity correction only requires an additional calculation according to the following equation:

$$RH_{Comp} = RH_{Sys} * (273.15 + T_{Comp}) / (273.15 + T_{Sys}) * 10^{(a * T_{Sys} / (b + T_{Sys}) - a * T_{Comp} / (b + T_{Comp}))}$$

with

T_{Sys} : T-comp temperature reading of the APC1 (see register 0x22 Table 14)

T_{Comp} : Compensated T_{Sys} temperature reading

RH_{Sys} : RH-comp relative humidity reading of the APC1 (see register 0x24 Table 14)

RH_{Comp} : Compensated RH_{Sys} relative humidity reading

a : 7.5 ($T \geq 0^{\circ}C$); factor, defined by physical laws

b : 237.3 ($T \geq 0^{\circ}C$); constant, defined by physical laws

9 Package drawings & markings

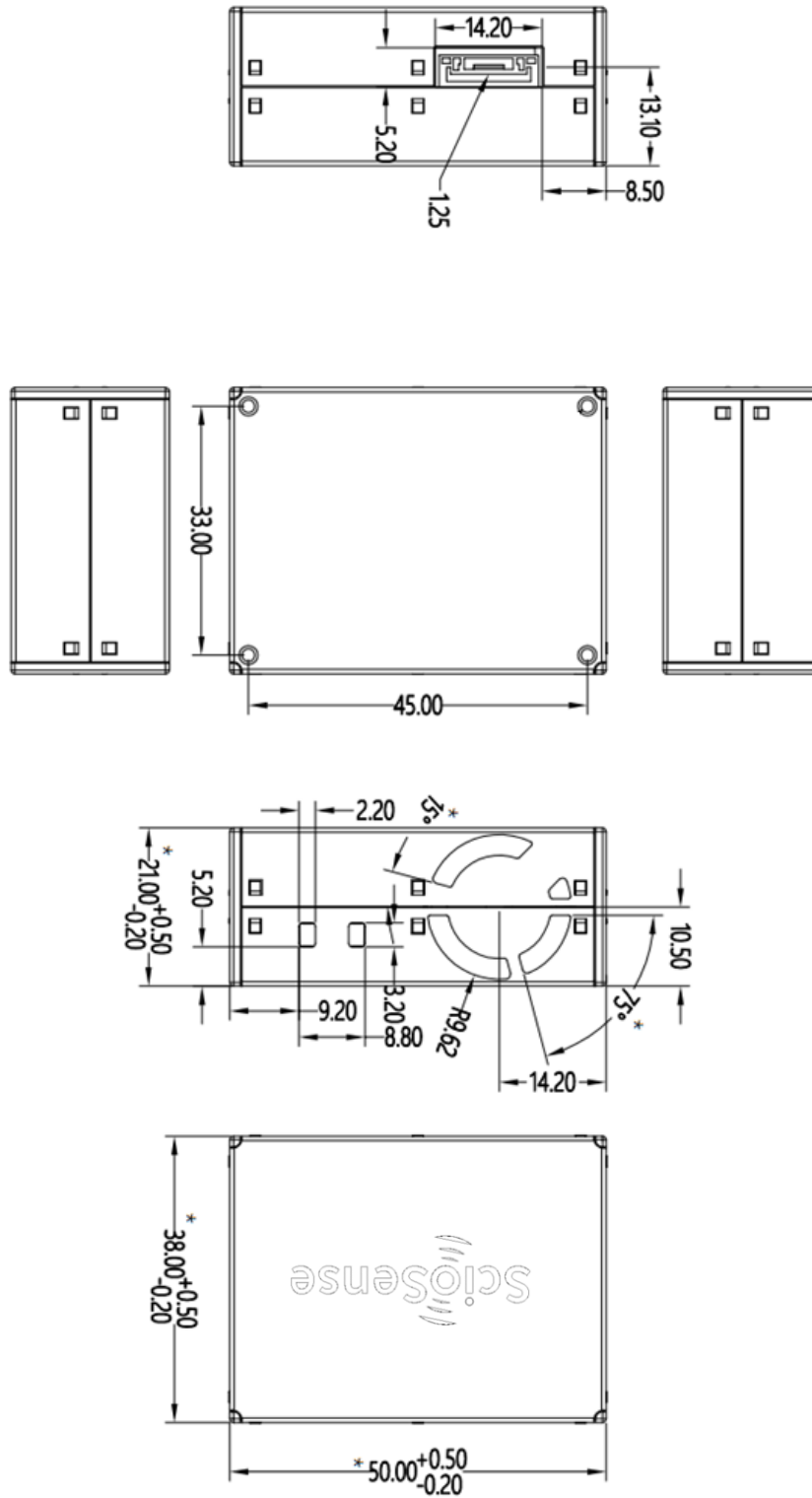

Figure 7: Technical Drawings (all dimensions in mm)



Figure 8: Product label

10 Ordering information

Table 19: Ordering information

Ordering Code	Material ID	Delivery Form	Delivery Quantity	Description
APC1001U	503700201	Box	200	UART interface
APC1001J	503700202	Box	200	I2C interface
APC1001U_EK_ST V1	503700xxx	Box	1 pce	Evaluation Kit

11 Shipment & Packaging

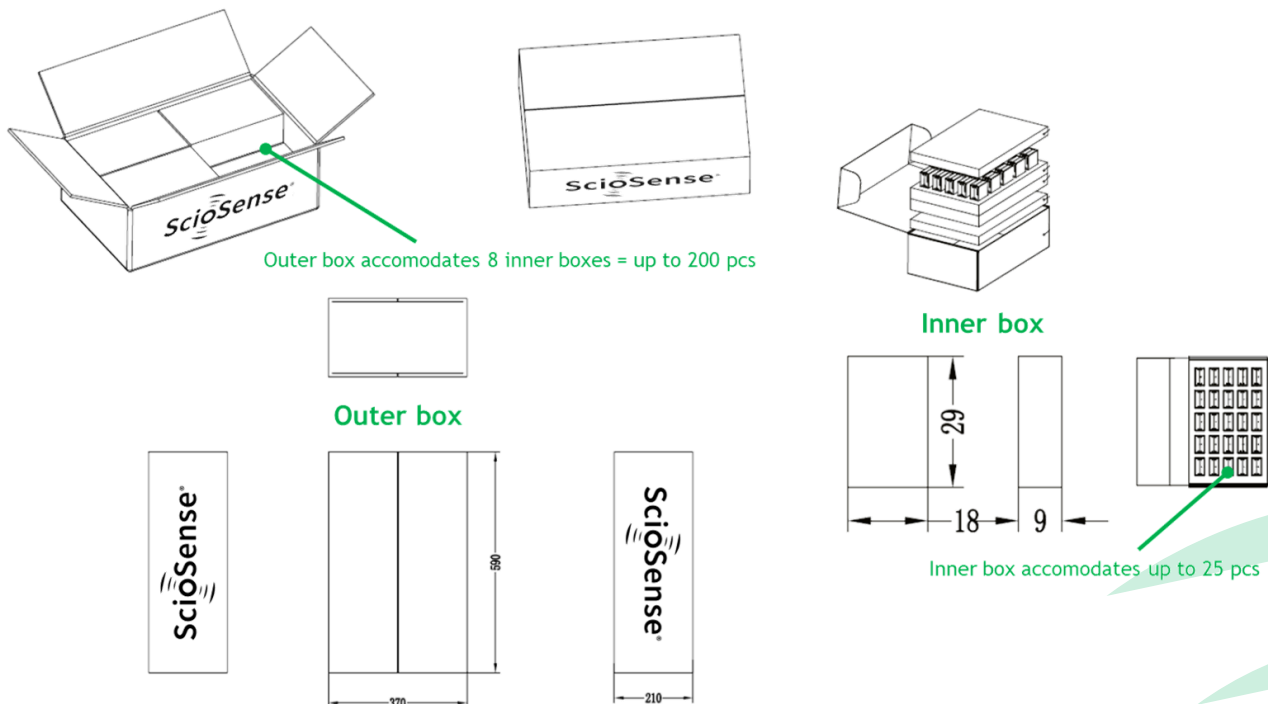

Figure 9: Packaging Information

12 RoHS Compliance & SciSense Green Statement

RoHS: The term RoHS compliant means that Sciosense B.V. products fully comply with current RoHS directives. Our semiconductor products do not contain any chemicals for all 6 substance categories, including the requirement that lead does not exceed 0.1% by weight in homogeneous materials. Where designed to be soldered at high temperatures, RoHS compliant products are suitable for use in specified lead-free processes.

SciSense Green (RoHS compliant and no Sb/Br): SciSense Green defines that in addition to RoHS compliance, our products are free of Bromine (Br) and Antimony (Sb) based flame retardants (Br or Sb do not exceed 0.1% by weight in homogeneous material).

Important Information: The information provided in this statement represents Sciosense B.V. knowledge and belief as of the date that it is provided. Sciosense B.V. bases its knowledge and belief on information provided by third parties, and makes no representation or warranty as to the accuracy of such information. Efforts are underway to better integrate information from third parties. Sciosense B.V. has taken and continues to take reasonable steps to provide representative and accurate information but may not have conducted destructive testing or chemical analysis on incoming materials and chemicals. Sciosense B.V. and Sciosense B.V. suppliers consider certain information to be proprietary, and thus CAS numbers and other limited information may not be available for release.

13 Copyrights & Disclaimer

Copyright Sciosense B.V High Tech Campus 10, 5656 AE Eindhoven, The Netherlands. Trademarks Registered. All rights reserved. The material herein may not be reproduced, adapted, merged, translated, stored, or used without the prior written consent of the copyright owner.

Devices sold by Sciosense B.V. are covered by the warranty and patent indemnification provisions appearing in its General Terms of Trade. Sciosense B.V. makes no warranty, express, statutory, implied, or by description regarding the information set forth herein. Sciosense B.V. reserves the right to change specifications and prices at any time and without notice. Therefore, prior to designing this product into a system, it is necessary to check with Sciosense B.V. for current information. This product is intended for use in commercial applications. Applications requiring extended temperature range, unusual environmental requirements, or high reliability applications, such as military, medical life-support or life-sustaining equipment are specifically not recommended without additional processing by Sciosense B.V. for each application. This product is provided by Sciosense B.V. "AS IS" and any express or implied warranties, including, but not limited to the implied warranties of merchantability and fitness for a particular purpose are disclaimed.

Sciosense B.V. shall not be liable to recipient or any third party for any damages, including but not limited to personal injury, property damage, loss of profits, loss of use, interruption of business or indirect, special, incidental or consequential damages, of any kind, in connection with or arising out of the furnishing, performance or use of the technical data herein. No obligation or liability to recipient or any third party shall arise or flow out of Sciosense B.V. rendering of technical or other services.

14 Document status

Table 20: Document status

Document Status	Product Status	Definition
Product Preview	Pre-Development	Information in this datasheet is based on product ideas in the planning phase of development. All specifications are design goals without any warranty and are subject to change without notice.
Preliminary Datasheet	Pre-Production	Information in this datasheet is based on products in the design, validation or qualification phase of development. The performance and parameters shown in this document are preliminary without any warranty and are subject to change without notice.
Datasheet	Production	Information in this datasheet is based on products in ramp-up to full production or full production which conform to specifications in accordance with the terms of SciSense B.V. standard warranty as given in the General Terms of Trade.
Datasheet (Discontinued)	Discontinued	Information in this datasheet is based on products which conform to specifications in accordance with the terms of SciSense B.V. standard warranty as given in the General Terms of Trade, but these products have been superseded and should not be used for new designs.

15 Revision information

Table 21: Revision history

Revision	Date	Comment	Page
1.0	2022-04-11	Official release	All
0.9.1	2022-02-23	Typos and beautification Amend table 14; add note	All 14, 15
0.9	2021-11-30	Preliminary Version	All

Note(s) and/or Footnote(s):

1. Page and figure numbers for the previous version may differ from page and figure numbers in the current revision.
2. Correction of typographical errors is not explicitly mentioned.