

RoHS Recast Compliant

## M.2 2242 Flash Drive

SS220-M242 Product Specifications



October 19, 2017

Version 1.4



**Apacer Technology Inc.**

1F, No.32, Zhongcheng Rd., Tucheng Dist., New Taipei City, Taiwan, R.O.C

Tel: +886-2-2267-8000 Fax: +886-2-2267-2261

[www.apacer.com](http://www.apacer.com)

## Features:

- **Compliance with SATA Interface**
  - Serial ATA Revision 3.1
  - SATA 6.0 Gbps
  - ATA-8 command set
  - Backward compatible with SATA 1.5/3.0 Gbps
- **Capacity**
  - 1, 2, 4, 8, 16, 32, 64 GB
- **Performance\***
  - Interface burst read/write: 600 MB/sec
  - Sequential read: up to 520 MB/sec
  - Sequential write: up to 455 MB/sec
  - Seq. read QD32: Up to 530 MB/sec
  - Seq. write QD32: Up to 445 MB/sec
  - Random read 4K: up to 79,000 IOPS
  - Random write 4K: up to 80,000 IOPS
- **Flash Management**
  - Built-in hardware ECC
  - Global Wear Leveling
  - Flash bad-block management
  - Flash Translation Layer: Page Mapping
  - S.M.A.R.T.
  - Power Failure Management
  - ATA Secure Erase
  - TRIM
- **SATA Power Management**
- **NAND Flash Type: SLC**
- **MTBF: >2,000,000 hours**
- **Temperature Range**
  - Operating:
    - Standard: 0°C to 70°C
    - Extended: -40°C to 85°C
  - Storage: -40°C to 100°C
- **Supply Voltage**
  - 3.3 V ± 5%
- **Power Consumption\***
  - Active mode: 570 mA
  - Idle mode: 85 mA
- **Connector Type**
  - 75-pin SATA-based M.2 module pinout
- **Form Factor**
  - M.2 2242-D2-B-M
  - Dimensions: 42.00 x 22.00 x 3.60, unit: mm
- **Shock & Vibration\*\***
  - Shock: 1,500 G
  - Vibration: 15 G
- **Thermal Sensor**
- **Thermal Management Technique (optional)**
- **Device Sleep (optional)**
- **LED Indicators for Drive Behavior**
- **RoHS Recast Compliant (Complies with 2011/65/EU Standard)**

\*Varies from capacities. The values for performances and power consumptions presented are typical and may vary depending on flash configurations or platform settings. The term idle refers to the standby state of the device.

\*\*Non-operating

## Table of Contents

<b>1. General Descriptions .....</b>	<b>3</b>
<b>2. Functional Block .....</b>	<b>3</b>
<b>3. Pin Assignments.....</b>	<b>4</b>
<b>4. Product Specifications.....</b>	<b>7</b>
4.1 Capacity.....	7
4.2 Performance .....	7
4.3 Environmental Specifications .....	8
4.4 Mean Time Between Failures (MTBF) .....	8
4.5 Certification and Compliance .....	8
4.6 LED Indicator Behavior.....	9
<b>5. Flash Management.....</b>	<b>10</b>
5.1 Error Correction/Detection.....	10
5.2 Bad Block Management .....	10
5.3 Global Wear Leveling .....	10
5.4 Flash Translation Layer – Page Mapping.....	10
5.5 ATA Secure Erase.....	10
5.6 Power Failure Management .....	11
5.7 TRIM .....	11
5.8 Thermal Sensor .....	11
5.9 Thermal Management Technique (optional) .....	11
5.10 SATA Power Management.....	12
5.11 DEVSLP (DevSleep or DEVSLP) Mode (optional).....	12
<b>6. Software Interface .....</b>	<b>13</b>
6.1 Command Set.....	13
6.2 S.M.A.R.T. ....	13
<b>7. Electrical Specifications .....</b>	<b>15</b>
7.1 Operating Voltage.....	15
7.2 Power Consumption .....	15
<b>8. Physical Characteristics.....</b>	<b>16</b>
8.1 Dimensions .....	16
<b>9. Product Ordering Information.....</b>	<b>17</b>
9.1 Product Code Designations.....	17
9.2 Valid Combinations.....	18

## 1. General Descriptions

Apacer's SS220-M242 (M.2 2242) is the next generation modularized Solid State Drive (SSD) with the shape of all new M.2 form factor, with the aim to be the more suitable for mobile and compact computers with standard width at only 22.00 mm. SS220-M242 appears in M.2 2242 mechanical dimensions and is believed to be the leading add-in storage solution for future host computing systems.

The M.2 SSD is designed with SATA-based connector pinouts, providing full compliance with the latest SATA Revision 3.1 interface specifications. Aside from SATA compliance, SS220-M242 delivers exceptional performance and power efficiency. On the other hand, the extreme thin and light form factor makes SS220-M242 the ideal choice for mobile computing systems, which appears to be the trend in near future.

Regarding reliability, SS220-M242 is built with a powerful SATA controller that supports on-the-module ECC as well as efficient wear leveling scheme. Since it is operating under SATA 6.0 Gbps interface, SS220-M242 is provided with Apacer latest S.M.A.R.T. that are primarily oriented for the latest SATA interface SSD, for drive lifetime monitoring and analyzing.

## 2. Functional Block

Apacer SS220-M242 includes a single-chip SATA 6.0 Gbps and the flash media. The controller integrates the flash management unit to support multi-channel, multi-bank flash arrays. Figure 2-1 shows the functional block diagram.

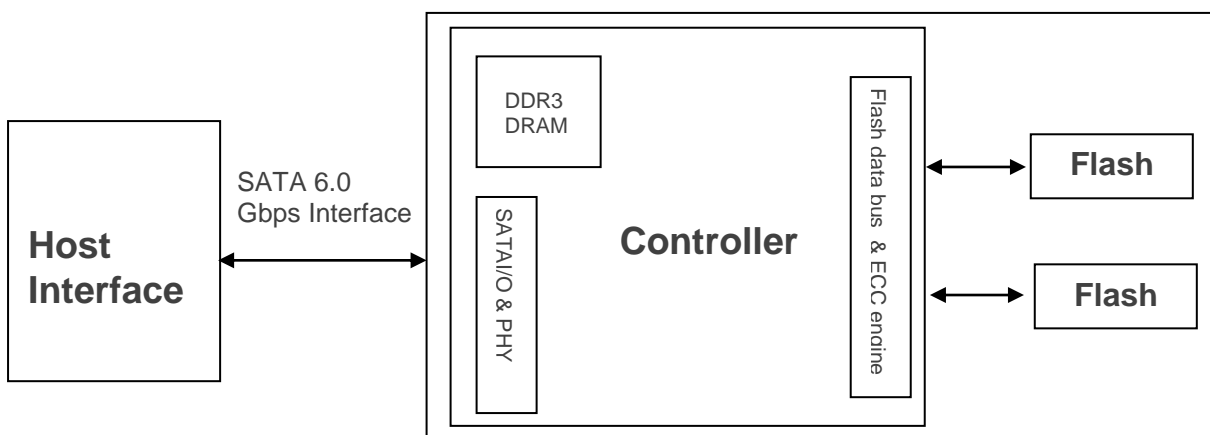
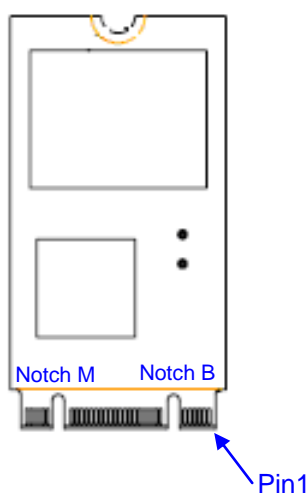

Figure 2-1 Block Diagram

### 3. Pin Assignments

This connector does not support hot plug capability. There are a total of 75 pins. 12 pin locations are used for mechanical key locations; this allows such a module to plug into both Key B and Key M connectors.



**Table 3-1** Pin Assignments

Pin	Type	Description
1	CONFIG_3	Ground (according to M.2 configurations for SSD-SATA definition)
2	3.3V	Supply Pin, 3.3V
3	GND	Ground
4	3.3V	Supply pin, 3.3V
5	No connect	No connect
6	Not available	No connect (used for other purposes)
7	Not available	No connect (used for other purposes)
8	Not available	No connect (used for other purposes)
9	No connect	No connect
10	DAS/DSS	Device Activity Signal/Disable Staggered Spin-up
11	No connect	No connect (used for other purposes)
12	(removed for key)	Mechanical notch B
13	(removed for key)	Mechanical notch B
14	(removed for key)	Mechanical notch B
15	(removed for key)	Mechanical notch B
16	(removed for key)	Mechanical notch B
17	(removed for key)	Mechanical notch B
18	(removed for key)	Mechanical notch B
19	(removed for key)	Mechanical notch B

Pin	Type	Description
20	Not available	No connect (used for other purposes)
21	CONFIG_0	Ground (according to M.2 configurations for SSD-SATA definition)
22	Not available	No connect (used for other purposes)
23	Not available	No connect (used for other purposes)
24	Not available	No connect (used for other purposes)
25	Not available	No connect (used for other purposes)
26	Not available	No connect (used for other purposes)
27	GND	Ground
28	Not available	No connect (used for other purposes)
29	PERn1	Not used
30	Not available	No connect (used for other purposes)
31	PERp1	Not used
32	Not available	No connect (used for other purposes)
33	GND	Ground
34	Not available	No connect (used for other purposes)
35	PETn1	Not used
36	Not available	No connect (used for other purposes)
37	PETp1	Not used
38	DEVSLP	Device Sleep, input. If driven high the host is informing the SSD to enter a low power state
39	GND	Ground
40	Not available	No connect (used for other purposes)
41	SATA-Rx+	Host receiver differential signal pair
42	Not available	No connect (used for other purposes)
43	SATA-Rx-	Host receiver differential signal pair
44	Not available	No connect (used for other purposes)
45	GND	Ground
46	Not available	No connect (used for other purposes)
47	SATA-Tx-	Host transmitter differential pair
48	Not available	No connect (used for other purposes)
49	SATA-Tx+	Host transmitter differential pair
50	PERST#	Not used
51	GND	Ground
52	CLKREQ#	Not used
53	REFCLKN	Not used
54	PEWAKE#	Not used
55	REFCLKP	Not used

Pin	Type	Description
56	MFG1	Manufacturing pin. Use determined by vendor (no connect on a host)
57	GND	Ground
58	MFG2	Manufacturing pin. Use determined by vendor (no connect on a host)
59	(removed for key)	Mechanical notch B
60	(removed for key)	Mechanical notch B
61	(removed for key)	Mechanical notch B
62	(removed for key)	Mechanical notch B
63	(removed for key)	Mechanical notch B
64	(removed for key)	Mechanical notch B
65	(removed for key)	Mechanical notch B
66	(removed for key)	Mechanical notch B
67	Not available	No connect (used for other purposes)
68	SUSCLK	Not used
69	CONFIG_1	Ground
70	3.3V	Supply pin, 3.3V
71	GND	Ground
72	3.3V	Supply pin, 3.3V
73	GND	Ground
74	3.3V	Supply pin, 3.3V
75	CONFIG_2	Ground

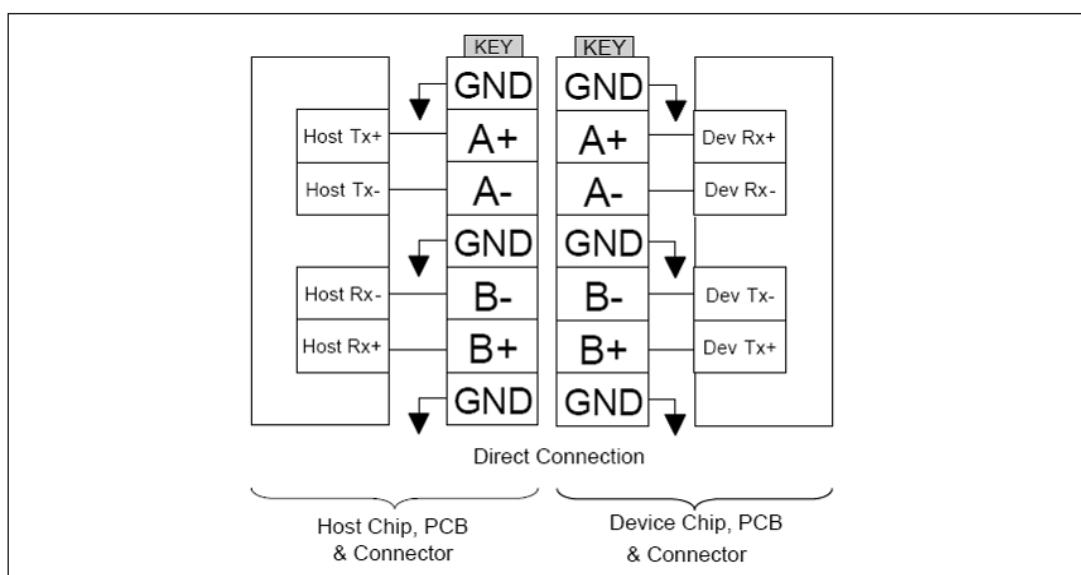

Figure 3-1 Direct Connection between the Host and Device

## 4. Product Specifications

### 4.1 Capacity

Capacity specifications of SS220-M242 are available as shown in Table 4-1. It lists the specific capacity and the default numbers of heads, sectors and cylinders for each product line.

**Table 4-1** Capacity Specifications

Capacity	Total bytes*	Cylinders	Heads	Sectors	Max LBA
1 GB	1,011,032,064	1,959	16	63	1,974,672
2 GB	2,011,226,112	3,897	16	63	3,928,176
4 GB	4,011,614,208	7,773	16	63	7,835,184
8 GB	8,012,390,400	15,525	16	63	15,649,200
16 GB	16,013,942,784	16,383	16	63	31,277,232
32 GB	32,017,047,552	16,383	16	63	62,533,296
64 GB	64,023,257,088	16,383	16	63	125,045,424

\*Display of total bytes varies from file systems, which means not all of the bytes can be used for storage.

\*\*Notes: 1 GB = 1,000,000,000 bytes; 1 sector = 512 bytes.

LBA count addressed in the table above indicates total user storage capacity and will remain the same throughout the lifespan of the device. However, the total usable capacity of the SSD is most likely to be less than the total physical capacity because a small portion of the capacity is reserved for device maintenance usages.

### 4.2 Performance

Performance of SS220-M242 is listed below in Table 4-2.

**Table 4-2** Performance Specifications

Capacity \ Performance	Capacity						
	1 GB	2 GB	4 GB	8 GB	16 GB	32 GB	64 GB
<b>Sequential Read* (MB/s)</b>	32	60	65	55	65	60	520
<b>Sequential Write* (MB/s)</b>	14	27	55	37	60	60	455
<b>Seq. Read QD32* (MB/s)</b>	32	60	65	60	65	65	530
<b>Seq. Write QD32* (MB/s)</b>	14	28	55	37	60	60	445
<b>Random Read IOPS** (4K)</b>	7,000	11,000	15,000	11,000	14,000	15,000	79,000
<b>Random Write IOPS** (4K)</b>	815	1,000	3,000	4,000	11,000	15,000	80,000

Note:

Results may differ from various flash configurations or host system setting.

\*Sequential performance is based on CrystalDiskMark 5.2.1 with file size 1,000MB.

\*\*Random performance measured using IOMeter with Queue Depth 32.



### 4.3 Environmental Specifications

Environmental specifications of SS220-M242 product follow MIL-STD-810 standards as shown in Table 4-3.

**Table 4-3** Environmental Specifications

Item	Specifications
Operating temp.	0°C to 70°C (Standard); -40°C to 85°C (Extended)
Non-operating temp.	-40°C to 100°C
Operating vibration	7.69 Grms, 20~2000 Hz/random (compliant with MIL-STD-810G)
Non-operating vibration	4.02 Grms, 15 ~ 2000 Hz/sine (compliant with MIL-STD-810G)
Operating shock	50(G), 11(ms), half-sine wave
Non-operating shock	1,500(G), 0.5(ms), half-sine wave

### 4.4 Mean Time Between Failures (MTBF)

Mean Time Between Failures (MTBF) is predicted based on reliability data for the individual components in SS220-M242. The prediction result for SS220-M242 is more than 2,000,000 hours.

Note: The MTBF is predicated and calculated based on “Telcordia Technologies Special Report, SR-332, Issue 2” method.

### 4.5 Certification and Compliance

SS220-M242 complies with the following standards:

- CE
- FCC
- RoHS Recast
- MIL-STD-810

## 4.6 LED Indicator Behavior

The behavior of the SS220-M242 LED indicators is described in Table 4-4.

**Table 4-4** LED Behavior

Location	LED	Description
LED A	DAS	LED blinks when the drive is being accessed
LED B	PHY	LED blinks when PHY is connected



## 5. Flash Management

### 5.1 Error Correction/Detection

SS220-M242 implements a hardware ECC scheme, based on the BCH algorithm. It can detect and correct up to 40 bit error in 1K bytes.

### 5.2 Bad Block Management

Current production technology is unable to guarantee total reliability of NAND flash memory array. When a flash memory device leaves factory, it comes with a minimal number of initial bad blocks during production or out-of-factory as there is no currently known technology that produce flash chips free of bad blocks. In addition, bad blocks may develop during program/erase cycles. When host performs program/erase command on a block, bad block may appear in Status Register. Since bad blocks are inevitable, the solution is to keep them in control. Apacer flash devices are programmed with ECC, page mapping technique and S.M.A.R.T to reduce invalidity or error. Once bad blocks are detected, data in those blocks will be transferred to free blocks and error will be corrected by designated algorithms.

### 5.3 Global Wear Leveling

Flash memory devices differ from Hard Disk Drives (HDDs) in terms of how blocks are utilized. For HDDs, when a change is made to stored data, like erase or update, the controller mechanism on HDDs will perform overwrites on blocks. Unlike HDDs, flash blocks cannot be overwritten and each P/E cycle wears down the lifespan of blocks gradually. Repeatedly program/erase cycles performed on the same memory cells will eventually cause some blocks to age faster than others. This would bring flash storages to their end of service term sooner. Global wear leveling is an important mechanism that levels out the wearing of all blocks so that the wearing-down of all blocks can be almost evenly distributed. This will increase the lifespan of SSDs.

### 5.4 Flash Translation Layer – Page Mapping

Page mapping is an advanced flash management technology whose essence lies in the ability to gather data, distribute the data into flash pages automatically, and then schedule the data to be evenly written. Page-level mapping uses one page as the unit of mapping. The most important characteristic is that each logical page can be mapped to any physical page on the flash memory device. This mapping algorithm allows different sizes of data to be written to a block as if the data is written to a data pool and it does not need to take extra operations to process a write command. Thus, page mapping is adopted to increase random access speed and improve SSD lifespan, reduce block erase frequency, and achieve optimized performance and lifespan.

### 5.5 ATA Secure Erase

ATA Secure Erase is an ATA disk purging command currently embedded in most of the storage drives. Defined in ATA specifications, (ATA) Secure Erase is part of Security Feature Set that allows storage drives to erase all user data areas. The erase process usually runs on the firmware level as most of the ATA-based storage media currently in the market are built-in with this command. ATA Secure Erase can securely wipe out the user data in the drive and protects it from malicious attack.

## 5.6 Power Failure Management

Power Failure Management plays a crucial role when experiencing unstable power supply. Power disruption may occur when users are storing data into the SSD. In this urgent situation, the controller would run multiple write-to-flash cycles to store the metadata for later block rebuilding. This urgent operation requires about several milliseconds to get it done. At the next power up, the firmware will perform a status tracking to retrieve the mapping table and resume previously programmed NAND blocks to check if there is any incompleteness of transmission.

## 5.7 TRIM

TRIM is a SATA command that helps improve the read/write performance and efficiency of solid-state drives (SSD). The command enables the host operating system to inform SSD controller which blocks contain invalid data, mostly because of the erase commands from host. The invalid will be discarded permanently and the SSD will retain more space for itself.

## 5.8 Thermal Sensor

Apacer Thermal Sensor is a digital temperature sensor with serial interface. By using designated pins for transmission, storage device owners are able to read temperature data.

## 5.9 Thermal Management Technique (optional)

Thermal management technique can monitor the temperature of the SSD equipped with a built-in thermal sensor via S.M.A.R.T. commands. This method can ensure the temperature of the device stays within temperature limits by drive throttling, i.e. reducing the speed of the drive when the device temperature reaches the threshold level, so as to prevent overheating, guarantee data reliability, and prolong product lifespan. When the temperature exceeds the maximum threshold level, thermal throttling will be triggered to reduce performance step by step to prevent hardware components from being damaged. Performance is only permitted to drop to the extent necessary for recovering a stable temperature to cool down the device's temperature. Once the temperature decreases to the minimum threshold value, transfer speeds will rise back to its optimum performance level.

## 5.10 SATA Power Management

By complying with SATA 6.0 Gb/s specifications, the SSD supports the following SATA power saving modes:

- ACTIVE: PHY ready, full power, Tx & Rx operational
- PARTIAL: Reduces power, resumes in under 10  $\mu$ s (microseconds)
- SLUMBER: Reduces power, resumes in under 10 ms (milliseconds)
- HIPM: Host-Initiated Power Management
- DIPM: Device-Initiated Power Management
- AUTO-SLUMBER: Automatic transition from partial to slumber.

Note: The behaviors of power management features would depend on host/device settings.

## 5.11 DEVSLP (DevSleep or DEVSLP) Mode (optional)

Device Sleep is a feature that allows SATA devices to enter a low power mode by designating pin 38 as DEVSLP signal with an aim to reducing power consumption.

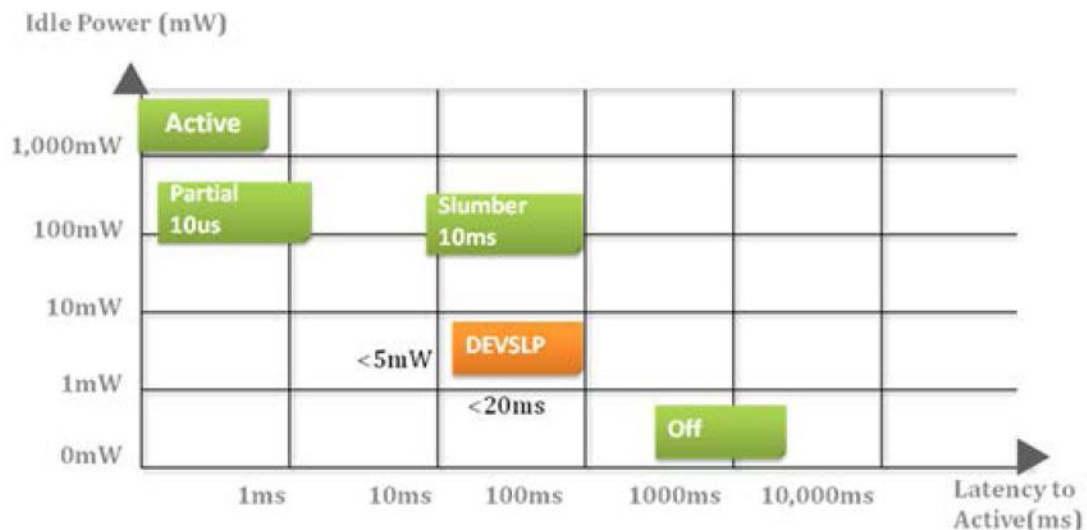

## 6. Software Interface

### 6.1 Command Set

This section defines the software requirements and the format of the commands the host sends to SS220-M242. Commands are issued to SS220-M242 by loading the required registers in the command block with the supplied parameters, and then writing the command code to the Command register.

Table 6-1 Command Set

Code	Command	Code	Command
E5h	Check Power Mode	F3h	Security Erase Prepare
06h	Data Set Management	F4h	Security Erase Unit
90h	Execute Device Diagnostic	F5h	Security Freeze Lock
E7h	Flush Cache	F1h	Security Set Password
EAh	Flush Cache EXT	F2h	Security Unlock
ECh	Identify Device	70h	Seek
E3h	Idle	EFh	Set Features
E1h	Idle Immediate	C6h	Set Multiple Mode
91h	Initialize Device Parameters	E6h	Sleep
C8h	Read DMA	B0h	SMART
25h	Read DMA EXT	E2h	Standby
C4h	Read Multiple	E0h	Standby Immediate
29h	Read Multiple EXT	CAh	Write DMA
20h	Read Sector	35h	Write DMA EXT
24h	Read Sector EXT	C5h	Write Multiple
40h	Read Verify Sectors	39h	Write Multiple EXT
42h	Read Verify Sectors EXT	30h	Write Sector
10h	Recalibrate	34h	Write Sector EXT
F6h	Security Disable Password		

### 6.2 S.M.A.R.T.

S.M.A.R.T. is an abbreviation for Self-Monitoring, Analysis and Reporting Technology, a self-monitoring system that provides indicators of drive health as well as potential disk problems. It serves as a warning for users from unscheduled downtime by monitoring and displaying critical drive information. Ideally, this should allow taking proactive actions to prevent drive failure and make use of S.M.A.R.T. information for future product development reference.

Apacer devices use the standard SMART command B0h to read data out from the drive to activate our S.M.A.R.T. feature that complies with the ATA/ATAPI specifications. S.M.A.R.T. Attribute IDs shall include initial bad block count, total later bad block count, maximum erase count, average erase count, power on hours and power cycle. When the S.M.A.R.T. Utility running on the host, it analyzes and reports the disk status to the host before the device reaches in critical condition.

Note: Attribute IDs may vary from product models due to various solution design and supporting capabilities.

Apacer memory products come with S.M.A.R.T. commands and subcommands for users to obtain information of drive status and to predict potential drive failures. Users can take advantage of the following commands/subcommands to monitor the health of the drive.

Code	SMART Subcommand
D0h	READ DATA
D1h	READ ATTRIBUTE THRESHOLDS
D2h	Enable/Disable Attribute Autosave
D4h	Execute Off-line Immediate
D5h	Read Log (optional)
D6h	Write Log (optional)
D8h	Enable Operations
D9h	Disable operations
DAh	Return Status

### General SMART attribute structure

Byte	Description
0	ID (Hex)
1 – 2	Status flag
3	Value
4	Worst
5*-11	Raw Data

\*Byte 5: LSB

### SMART attribute ID list

ID (Hex)	Attribute Name
9 (0x09)	Power-on hours
12 (0x0C)	Power cycle count
163 (0xA3)	Max. erase count
164 (0xA4)	Avg. erase count
166 (0xA6)	Total later bad block count
167 (0xA7)	SSD Protect Mode (vendor specific)
168 (0xA8)	SATA PHY Error Count
175 (0xAF)	Bad Cluster Table Count
192 (0xC0)	Unexpected Power Loss Count
194 (0xC2)	Temperature
241 (0xF1)	Total sectors of write

## 7. Electrical Specifications

### 7.1 Operating Voltage

Table 7-1 lists the supply voltage for SS220-M242.

**Caution: Absolute Maximum Stress Ratings** – Applied conditions greater than those listed under “Absolute Maximum Stress Ratings” may cause permanent damage to the device. This is a stress rating only and functional operation of the device at these conditions or conditions greater than those defined in the operational sections of this data sheet is not implied. Exposure to absolute maximum stress rating conditions may affect device reliability.

**Table 7-1** Operating Range

Item	Range
Supply Voltage	3.3V ± 5% (3.135-3.465V)

### 7.2 Power Consumption

Table 7-2 lists the power consumption for SS220-M242.

**Table 7-2** Power Consumption

Mode \ Capacity	Capacity							
	1 GB	2 GB	4 GB	8 GB	16 GB	32 GB	64 GB	
Active (mA)	210	235	270	230	265	280	570	
Idle (mA)	80	80	75	85	85	80	75	

Note:

\*All values are typical and may vary depending on flash configurations or host system settings.

\*\*Active power is an average power measurement performed using CrystalDiskMark with 128KB sequential read/write transfers.



## 8. Physical Characteristics

### 8.1 Dimensions

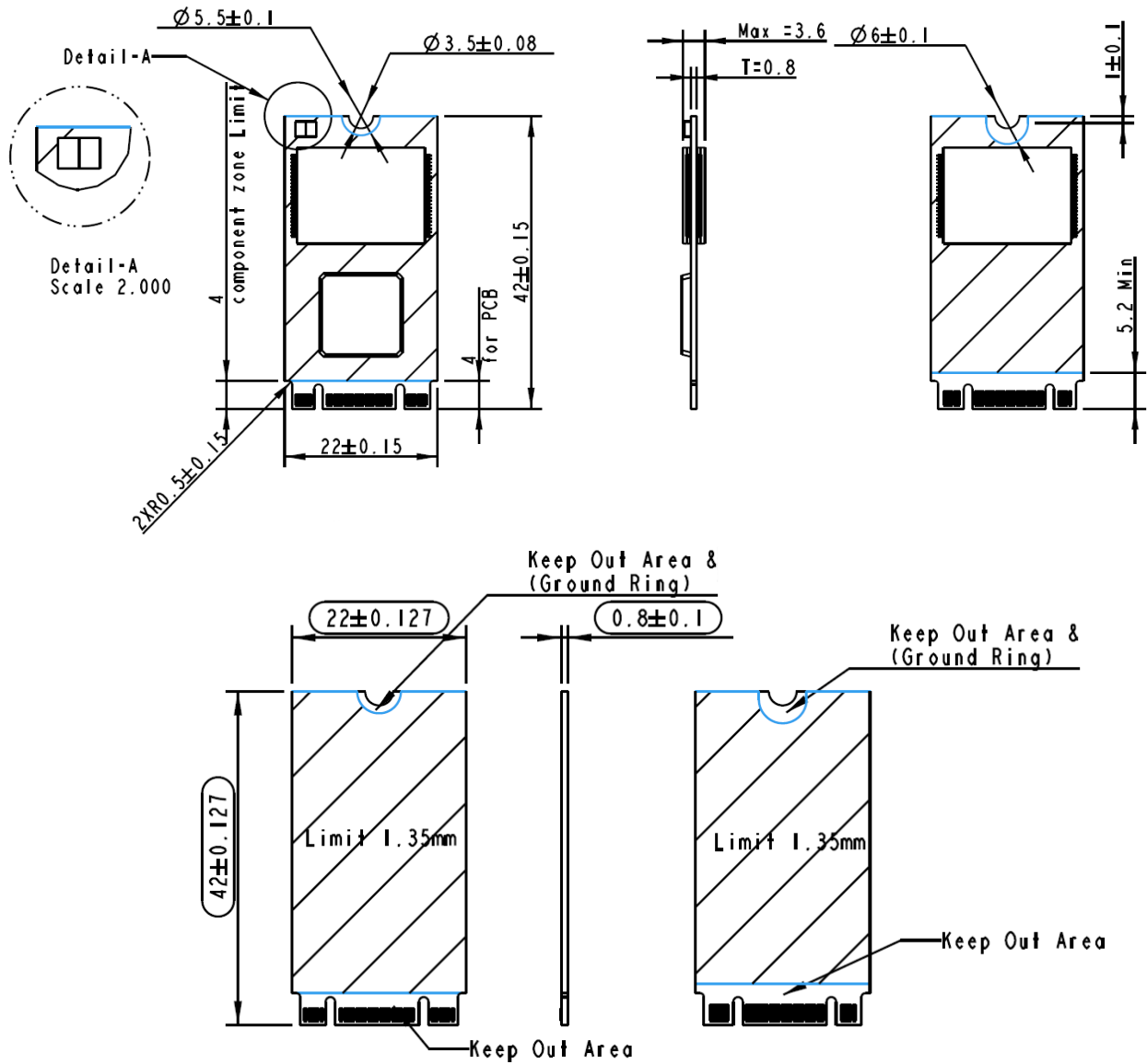

## 9. Product Ordering Information

### 9.1 Product Code Designations

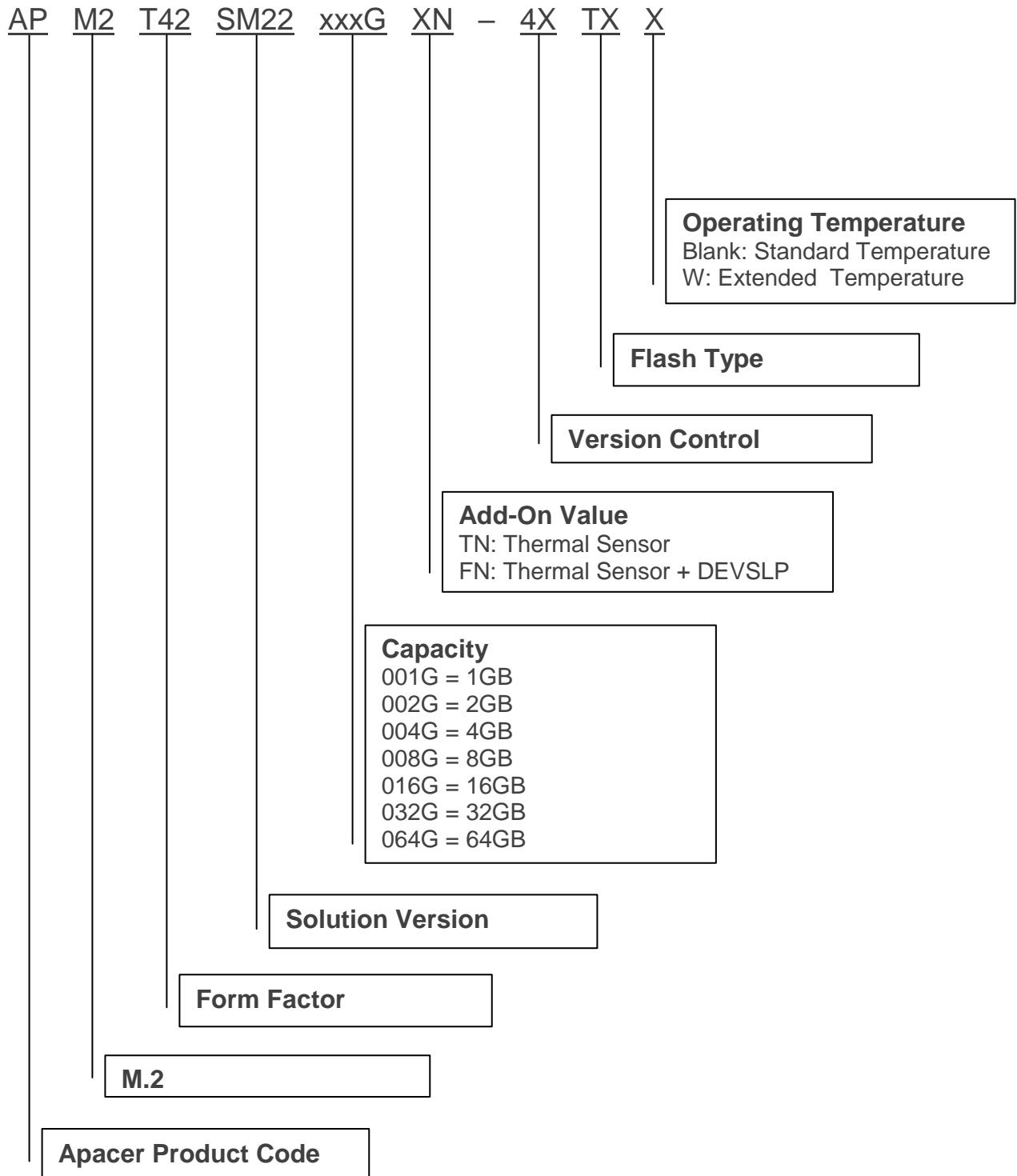

## 9.2 Valid Combinations

### 9.2.1 Without DEVSLP

Capacity	Standard Temperature	Extended Temperature
1GB	APM2T42SM22001GTN-4ET	APM2T42SM22001GTN-4ETW
2GB	APM2T42SM22002GTN-4ET	APM2T42SM22002GTN-4ETW
4GB	APM2T42SM22004GTN-4ET	APM2T42SM22004GTN-4ETW
8GB	APM2T42SM22008GTN-4ET	APM2T42SM22008GTN-4ETW
16GB	APM2T42SM22016GTN-4ET	APM2T42SM22016GTN-4ETW
32GB	APM2T42SM22032GTN-4ET	APM2T42SM22032GTN-4ETW
64GB	APM2T42SM22064GTN-4ETG	APM2T42SM22064GTN-4ETGW

### 9.2.2 With DEVSLP (optional)

Capacity	Standard Temperature	Extended Temperature
1GB	APM2T42SM22001GTN-4FT	APM2T42SM22001GTN-4FTW
2GB	APM2T42SM22002GTN-4FT	APM2T42SM22002GTN-4FTW
4GB	APM2T42SM22004GTN-4FT	APM2T42SM22004GTN-4FTW
8GB	APM2T42SM22008GTN-4FT	APM2T42SM22008GTN-4FTW
16GB	APM2T42SM22016GTN-4FT	APM2T42SM22016GTN-4FTW
32GB	APM2T42SM22032GTN-4FT	APM2T42SM22032GTN-4FTW
64GB	APM2T42SM22064GTN-4FTG	APM2T42SM22064GTN-4FTGW

**Note:** Valid combinations are those products in mass production or will be in mass production. Consult your Apacer sales representative to confirm availability of valid combinations and to determine availability of new combinations.

## Revision History

Revision	Description	Date
0.1	Preliminary release	3/22/2017
1.0	Official release	5/11/2017
1.1	Added 64GB support	6/14/2017
1.2	Added a figure to 3. Pin Assignments	7/13/2017
1.3	Updated product ordering information for 64GB	7/31/2017
1.4	Updated seq. read/write QD32 performance for 64GB	10/19/2017