

## SPI/QPI PSRAM

---

### Specifications

- **Single Supply Voltage**
  - $V_{DD}=1.62$  to  $1.98V$
- **Interface:** SPI/QPI with SDR mode
- **Performance:** Clock rate up to
  - 144MHz for Wrapped Burst operation
  - 84MHz for Linear 512 Burst operation
- **Organization:** 16Mb, 2M x 8bits
- **Addressable Bit Range:** A[20:0]
- **Page Size:** 512 bytes
- **Refresh:** Self-managed
- **Operating Temperature Range**
  - $T_c=-40^{\circ}C$  to  $+85^{\circ}C$  (standard range)
  - $T_c=-40^{\circ}C$  to  $+105^{\circ}C$  (extended range)
- **Maximum Standby Current**
  - $150\mu A$  @  $105^{\circ}C$
  - $100\mu A$  @  $85^{\circ}C$
  - $25\mu A$  @  $25^{\circ}C$

### Features

- **Output Driver LVCMOS** with programmable drive strengths of 50, 100 and  $200\Omega$
- **Dedicated Wrapped Burst** read and write commands
- **Linear 512 Length Burst** is supported up to 84MHz and can cross page boundary as long as  $t_{CEM}$  is met
- **Register Configurable Wrap Lengths** of 16, 32, 64 and 512
- **Toggle Command** to switch between configurable wrap length and 32 bytes wrap
- **Software Reset**

## Table of Contents

### 1 Table of Contents

1	Table of Contents .....	2
2	Introduction .....	4
3	Package Information .....	4
3.1	Package Types : SOP / USON (SN, ZR) , not to scale, Top view.....	4
4	Package Outline Drawing .....	5
4.1	SOP-8L(150), package code SN .....	5
4.2	USON-8L 3x2mm, package code ZR .....	6
5	Ordering Information .....	7
6	Signal Table .....	7
7	Block Diagram .....	8
8	Power-Up Initialization .....	9
9	Interface Description .....	10
9.1	Address Space .....	10
9.2	Page Length.....	10
9.3	Drive Strength .....	10
9.4	Power-on Status.....	10
10	Mode Register Definition .....	11
11	Command/Address Latching Truth Table .....	12
11.1	Command Termination .....	13
12	Mode Register Operations.....	14
12.1	SPI MR Read Operation.....	14
12.2	SPI MR Write Operation.....	14
12.3	QPI MR Read Operation.....	15
12.4	QPI MR Write Operation.....	15
13	Read ID .....	16
13.1	SPI Read ID Operation.....	16
13.2	QPI Read ID Operation.....	17
14	Toggle Burst Length Operation .....	18

---

15	SPI Mode Operations .....	19
15.1	SPI Read Operations.....	19
15.2	SPI Write Operations.....	21
15.3	SPI Quad Mode Enable Operation .....	22
16	QPI Mode Operations .....	23
16.1	QPI Read Operations.....	23
16.2	QPI Write Operation(s) .....	24
16.3	QPI Quad Mode Exit operation.....	24
17	Reset Operation .....	25
18	Input/Output Timing.....	26
19	Electrical Specifications: .....	27
19.1	Absolute Maximum Ratings .....	27
19.2	Pin Capacitance .....	27
19.3	Operating Conditions .....	28
19.4	DC Characteristics .....	29
19.5	AC Characteristics .....	30
20	Change Log.....	31

## 2 Introduction

This Pseudo-SRAM device features a high speed, low pin count interface. It has 4 I/O pins and operates in SPI(serial peripheral interface) or QPI (quad peripheral interface) mode with frequencies up to 144 MHz. The data input (A/DQ) to the memory relies on clock (CLK) to latch all instructions, addresses and data. It is most suitable for low-power and low cost portable applications. It incorporates a seamless self-managed refresh mechanism. Hence it does not require the support of DRAM refresh from system host. The self-refresh feature is a special design to maximize performance of memory read operation.

## 3 Package Information

The APS1604M-SQR is available in standard package including 8-lead SOP-8L(150) and advanced package including 8-lead USON-8L 3x2mm.

### 3.1 Package Types : SOP / USON (SN, ZR) , not to scale, Top view

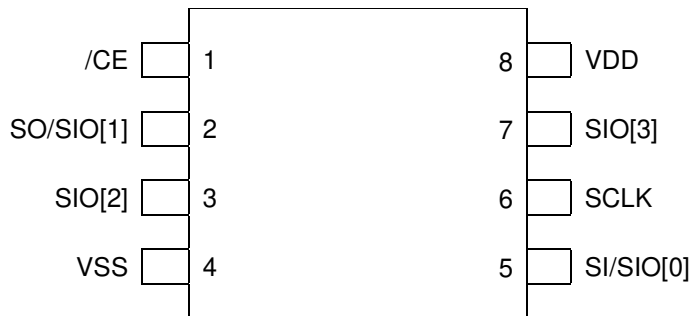

## 4 Package Outline Drawing

### 4.1 SOP-8L(150), package code SN

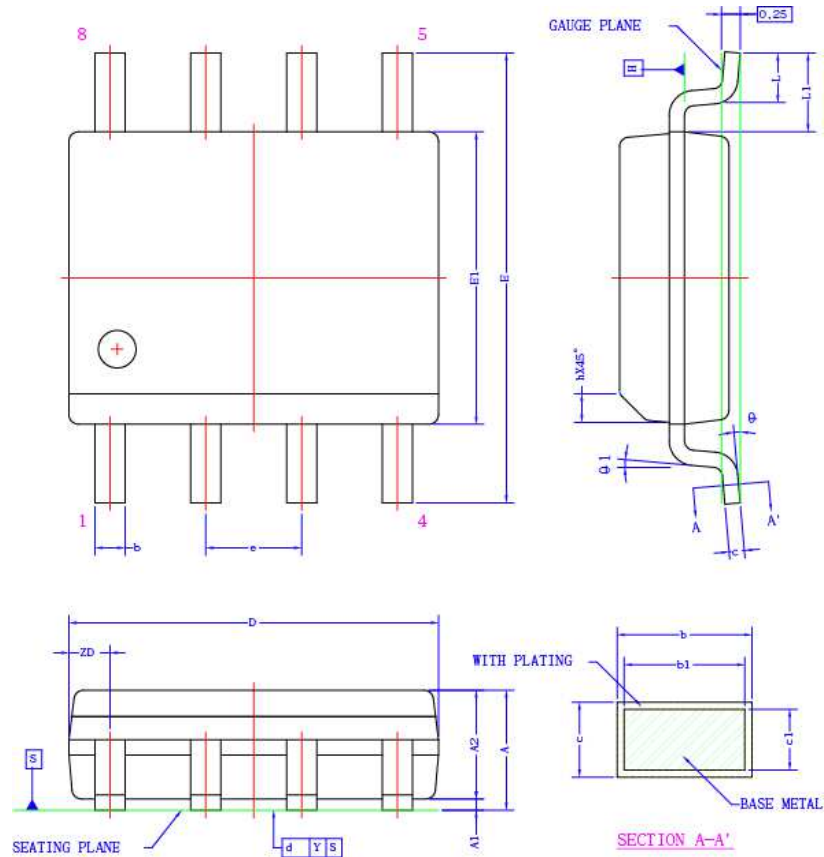

SYMBOL	DIMENSION (MM)			DIMENSION (MIL)		
	MIN.	NOM.	MAX.	MIN.	NOM.	MAX.
A	1.35	1.60	1.75	53	63	69
A1	0.10	0.15	0.25	4	6	10
A2	1.35	1.45	1.55	53	57	61
b	0.31	-	0.51	12	-	20
b1	0.28	0.40	0.48	11	16	19
c	0.17	-	0.25	7	-	10
c1	0.17	0.20	0.23	7	8	9
D	4.80	4.90	5.00	189	193	197
E	6.00 BSC			236 BSC		
E1	3.80	3.90	4.00	150	154	157
e	1.27 BSC			50 BSC		
L	0.40	0.66	1.27	16	26	50
L1	1.05 REF			41 REF		
ZD	0.55 REF			22 REF		
h	0.25	0.38	0.50	10	15	20
Y	-	-	0.10	-	-	4
θ	0°	-	8°	0°	-	8°
θ1	0°	-	-	0°	-	-

NOTE :

- REFER TO JEDEC STD: MS-012 AA.
- DIMENSION 'D' DOES NOT INCLUDE MOLD FLASH, PROTRUSION OR GATE BURRS. MOLD FLASH, PROTRUSION AND GATE BURRS SHALL NOT EXCEED 0.15mm PER SIDE.  
DIMENSION 'E1' DOES NOT INCLUDE INTERLEAD MOLD FLASH OR PROTRUSION. INTERLEAD MOLD FLASH OR PROTRUSION SHALL NOT EXCEED 0.25mm PER SIDE.  
'D' AND 'E1' DIMENSIONS ARE DETERMINED AT DATUM H .
- DIMENSION 'b' DOES NOT INCLUDE DAMBAR PROTRUSION.  
ALLOWABLE DAMBAR PROTRUSION SHALL BE 0.10mm TOTAL IN EXCESS OF THE 'b' DIMENSION AT MAXIMUM MATERIAL CONDITION.  
THE DAMBAR CANNOT BE LOCATED ON THE LOWER RADIUS OF THE FOOT.

## 4.2 USON-8L 3x2mm, package code ZR

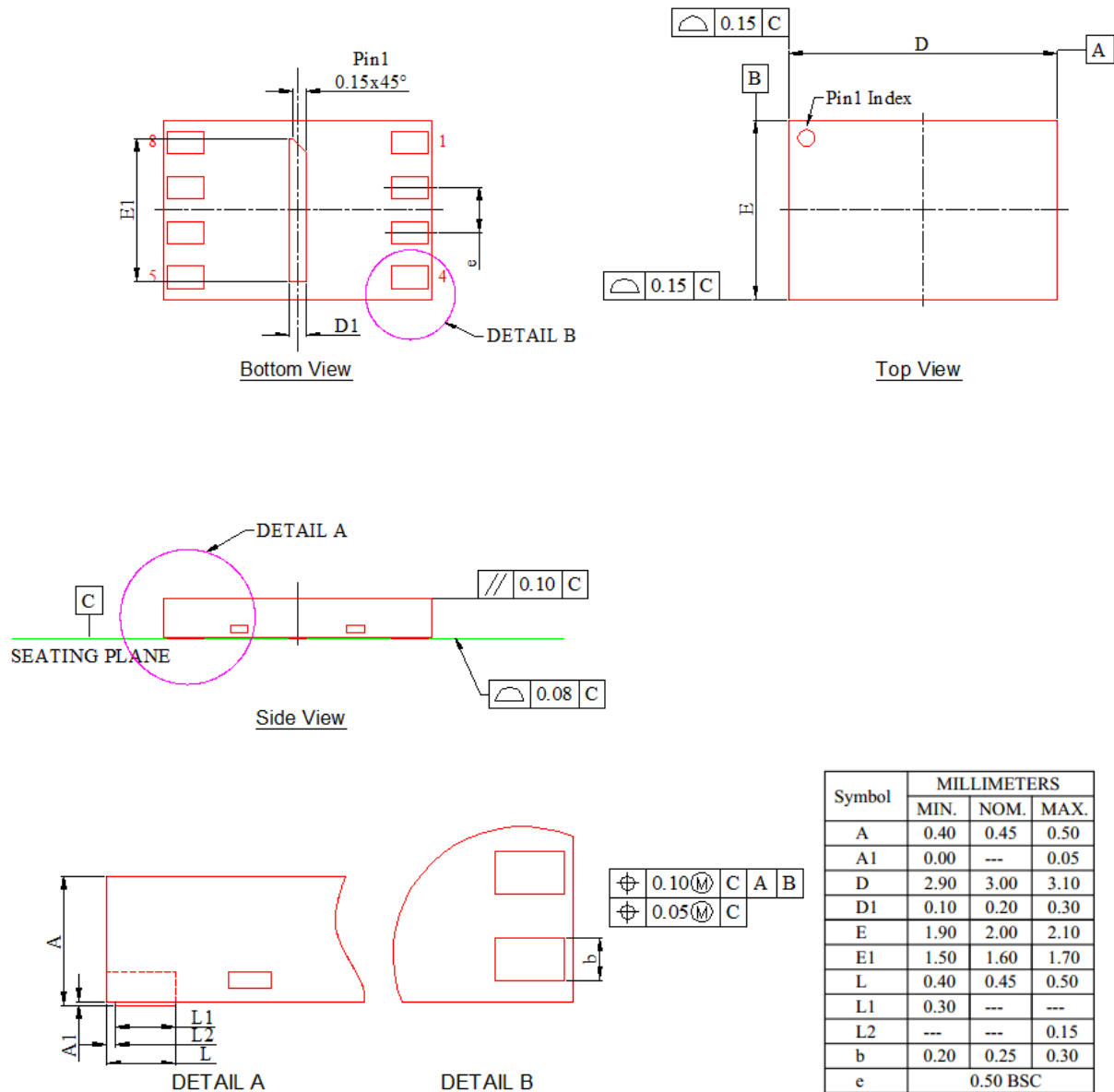

**NOTE:**

1. Scale 1:4
2. ALL DIMENSIONS AND TOLERANCES TAKE REFERENCE TO JEDEC MO-229
3. DIMENSION "b" APPLIES TO METALLIZED TERMINAL AND IS MEASURED BETWEEN 0.15MM AND 0.30MM FROM THE TERMINAL TIP. IF THE TERMINAL HAS OPTIONAL RADIUS ON THE OTHER END OF THE TERMINAL, THE DIMENSION B SHOULD NOT BE MEASURED IN THAT RADIUS AREA.

## 5 Ordering Information

**Table 1: Ordering Information**

Part Number	Temperature Range	Max Frequency	Note
APS1604M-SQR-ZR	Tc=-25°C to +85°C	144 MHz*	USON-8
APS1604M-SQR-SN	Tc=-40°C to +85°C	144 MHz*	SOP-8
APS1604M-SQRX-SN	Tc=-40°C to +105°C	144 MHz*	SOP-8

Note \*: 144MHz for Wrapped Burst operation

84MHz for Linear 512 Burst operation with RBX(row boundary crossing)

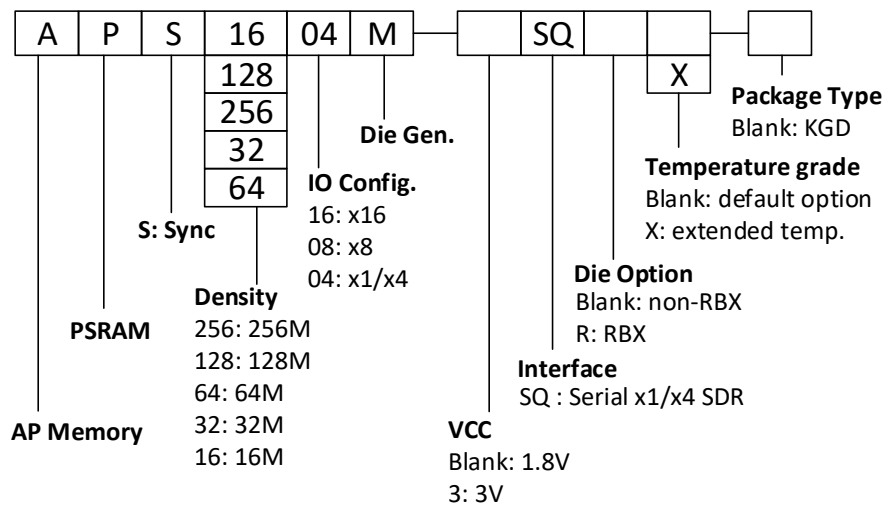

## 6 Signal Table

All signals are listed in Table 2.

**Table 2: Signals Table**

Symbol	Type	SPI Mode Function	QPI Mode Function	Comments
VDD	Power	Core supply 1.8V		
VSS	Ground	Core supply ground		
CE#	Input	Chip select, active low. When CE#=1, chip is in standby state		
CLK	Input	Clock Signal		
SI/SIO[0]	IO	Serial Input	IO[0]*	
SO/SIO[1]	IO	Serial Output	IO[1]*	
SIO[2]	IO	--	IO[2]*	
SIO[3]	IO	--	IO[3]*	

Note \*: SPI Quad mode

### 7 Block Diagram

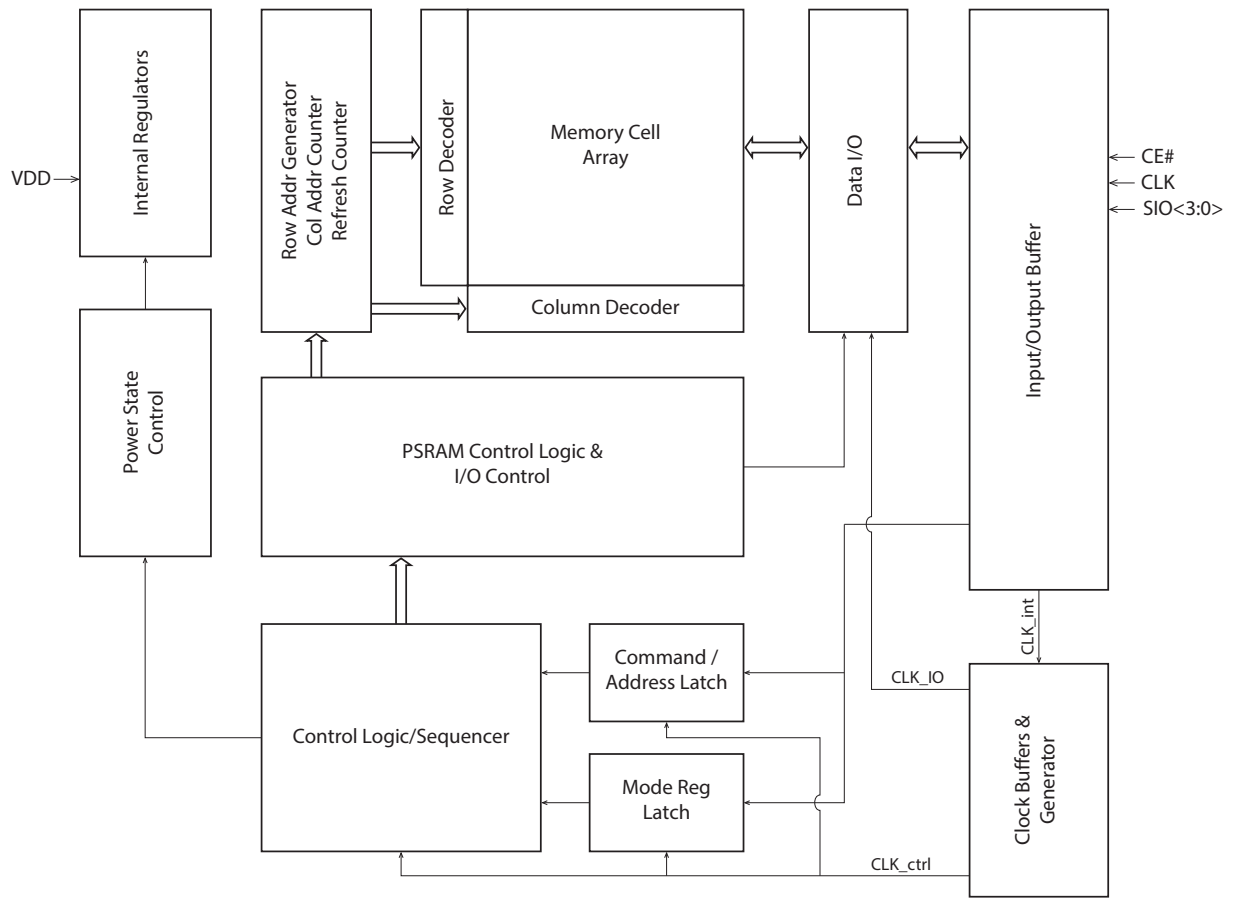



## 8 Power-Up Initialization

SPI/QPI products include an on-chip voltage sensor used to start the self-initialization process. When  $V_{DD}$  reaches a stable level at or above minimum  $V_{DD}$ , the device will require  $150\mu\text{s}$  and user-issued RESET Operation (see section 17) to complete its self-initialization process. From the beginning of power ramp to the end of the  $150\mu\text{s}$  period, CLK should remain LOW, CE# should remain HIGH (track  $V_{DD}$  within 200mV) and SI/SO/SIO[3:0] should remain LOW.

After the  $150\mu\text{s}$  period the device is ready for normal operation.

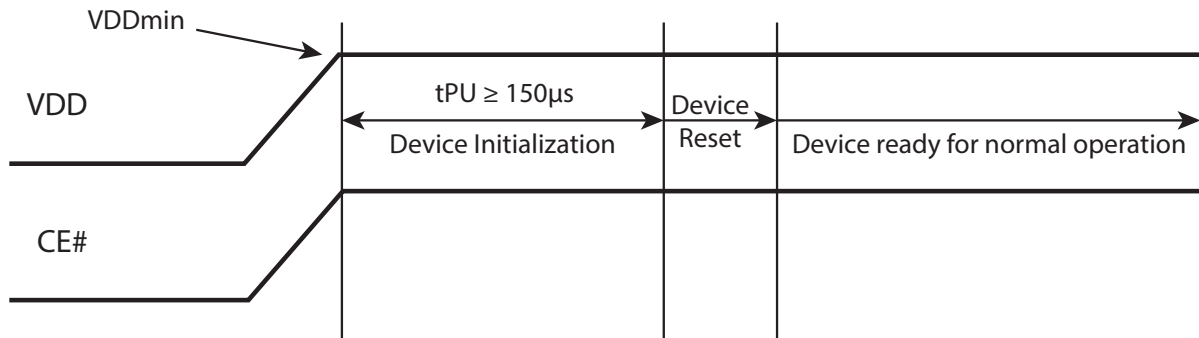

Figure 1. Power-Up Initialization Timing

## 9 Interface Description

### 9.1 Address Space

SPI/QPI PSRAM device is byte-addressable. 16M device is addressed with A[20:0].

### 9.2 Page Length

Read and write operations are default page size of 512 bytes.

### 9.3 Drive Strength

The device powers up in 50Ω.

### 9.4 Power-on Status

The device powers up in SPI Mode. It is required to have CE# high before beginning any operations.

## 10 Mode Register Definition

**Table 3: Mode Register Table**

MR No.	MA[3:0]	Access	OP7	OP6	OP5	OP4	OP3	OP2	OP1	OP0
0	`h0	R/W	rsvd.	Wrap		rsvd.		DQ Zout		

**Table 4: Wrap Codes MR0[6:5]**

Wrap Burst Settings		Page Boundary Crossing	
MR0[6:5]	Wrapped Length	Non-Wrap CMDs (`h03,`h0B,`hEB,`h02,`h38)	Wrap CMDs(`h8B,`h82)
00	16	Wrap 16, no cross page boundary	
01	32	Wrap 32, no cross page boundary	
10	64	Wrap 64, no cross page boundary	
11 (default)	512 (page size)	Linear, can cross page boundary	Wrap 512, no cross page boundary

**Table 5: DQ Output Drive Strength Codes MR0[1:0]**

DQ Output Drive Strength	
MR0[1:0]	Impedance
00(default)	50Ω
01	100Ω
10	200Ω
others	reserved

## 11 Command/Address Latching Truth Table

Command	Code	SPI Mode (QE=0)					QPI Mode (QE=1)				
		Cmd	Addr	Wait Cycle	DIO	Max Freq.	Cmd	Addr	Wait Cycle	DIO	Max Freq.
Read	'h03	S	S	0	S	33	N/A				
Fast Read	'h0B	S	S	8	S	144/84*	Q	Q	4	Q	66
Fast Read Quad	'hEB	S	Q	6	Q	144/84*	Q	Q	6	Q	144/84*
Write	'h02	S	S	0	S	144/84*	Q	Q	0	Q	144/84*
Quad Write	'h38	S	Q	0	Q	144/84*	same as 'h02				
Wrapped Read	h8B	S	S	8	S	144	Q	Q	6	Q	144
Wrapped Write	h82	S	S	0	S	144	Q	Q	0	Q	144
Mode Register Read	hB5	S	S	8	S	144	Q	Q	6	Q	144
Mode Register Write	hB1	S	S	0	S	144	Q	Q	0	Q	144
Enter Quad Mode	'h35	S	-	-	-	144	N/A				
Exit Quad Mode	'hF5	N/A					Q	-	-	-	144
Reset Enable	'h66	S	-	-	-	144	Q	-	-	-	144
Reset	'h99	S	-	-	-	144	Q	-	-	-	144
Burst Length Toggle	'hC0	S	-	-	-	144	Q	-	-	-	144
Read ID	'h9F	S	S	0	S	33	N/A				

Remark: S = Serial IO, Q = Quad IO

The device recognizes the following commands specified by the various input methods.

Note \*: Linear 512 Length burst can be performed *crossing page boundary(RBX)* by non-Wrapped burst commands issued while Burst Length Toggle is set to MR default setting of MRO[6:5]=11. Frequency limits are therefore: *Max Freq.* is up to 84MHz when *Linear 512 Length*, and *Max Freq.* is 144MHz under Wrapped Burst Operation.



## 12 Mode Register Operations

### 12.1 SPI MR Read Operation

For all reads, MR data will be available  $t^{\text{ACLK}}$  after the falling edge of CLK.

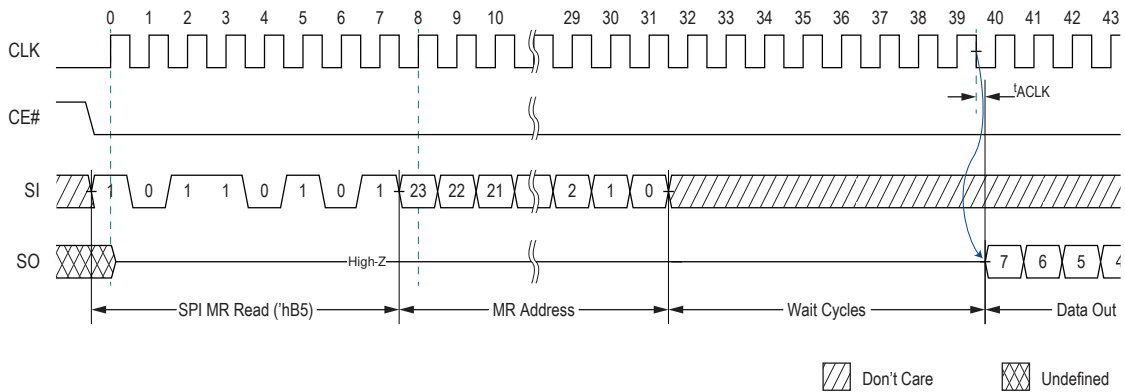

Figure 4: SPI MR Read 'hB5'

### 12.2 SPI MR Write Operation

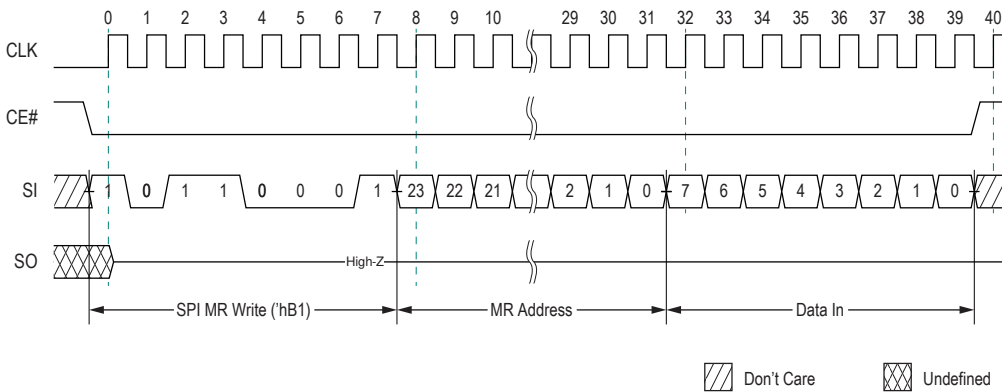

Figure 5: SPI MR Write 'hB1'

### 12.3 QPI MR Read Operation

For all reads, MR data will be available  $t^{\text{ACLK}}$  after the falling edge of CLK.

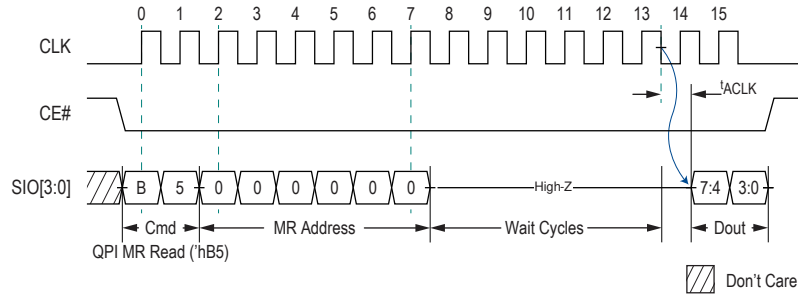

Figure 6: QPI MR Read 'hB5

### 12.4 QPI MR Write Operation

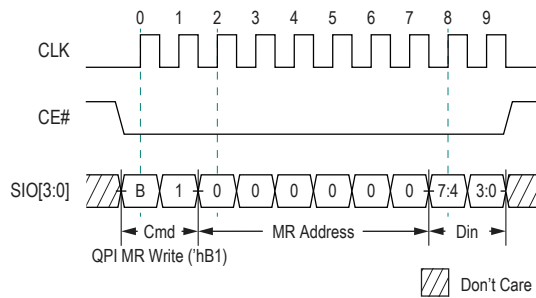

Figure 7: QPI MR Write 'hB1

### 13 Read ID

Read ID command provides information of vendor ID, known-good-die, device density, and manufacturing ID. It can be executed under the following 2 conditions: (Please see the following Figure 8)

1. Run it as the first operation after power up and before any other commands being executed.
2. Issue a memory read command with address = 'h00000 first, then Read ID command.
3. Issue a pre-condition of dummy read id, then Read ID command.

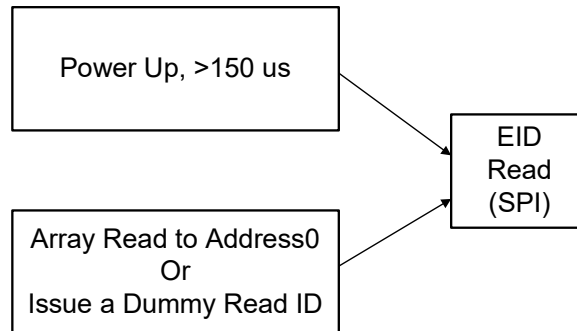

Figure 8: Pre-condition of EID Read

#### 13.1 SPI Read ID Operation

This command is similar to Fast Read, but without the wait cycles and the device outputs EID value instead of data.

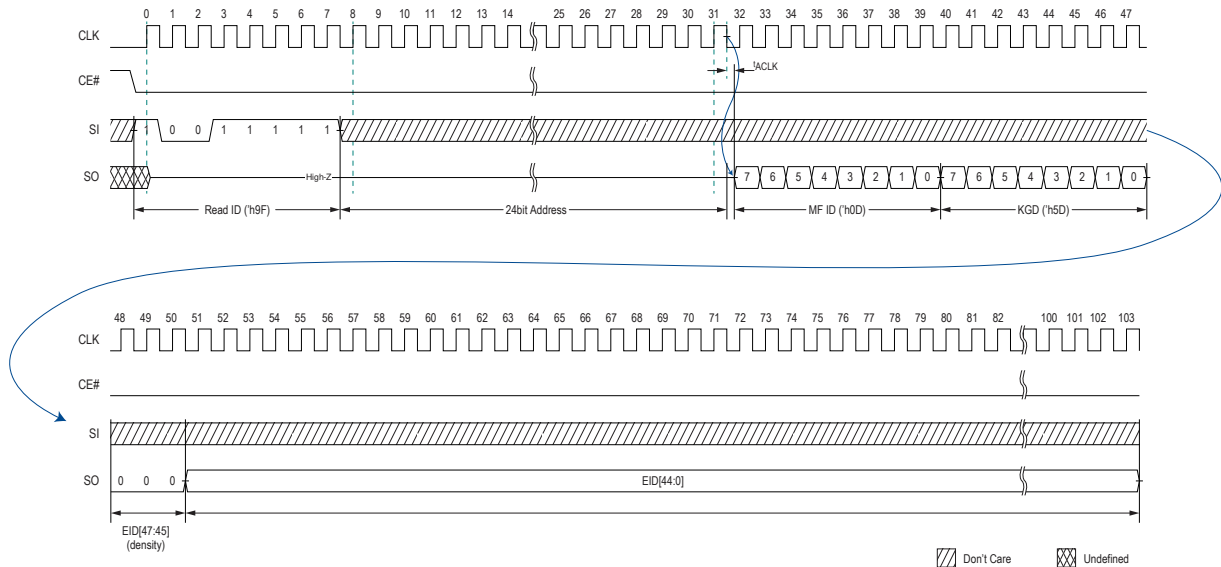

Figure 9: SPI Read ID 'h9F (available only in SPI mode)



### 13.2 QPI Read ID Operation

In QPI mode Read ID command is basically an QPI MR Read, but with particular attention to the Dout[7]. MRR data out bit[7] outputs serial ID data which is repeated every two clocks.

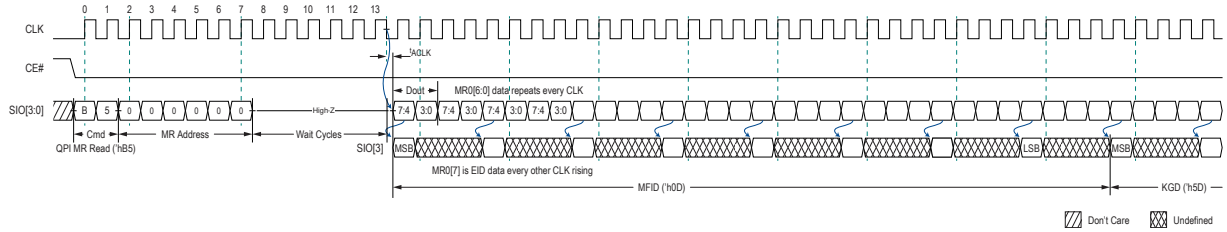

Figure 10: QPI Read ID (MR Read 'hB5) (max freq 84MHz)

Table 6: Known Good Die (KGD)

KGD[7:0]	Known Good Die
'b0101_0101	FAIL
'b0101_1101	PASS

\*Note: Default is FAIL die, and only mark PASS after all tests passed.

## 14 Toggle Burst Length Operation

The Toggle Burst Length Operation switches the device's wrapped burst boundary between the Mode Register setting (default of 512 bytes CA[8:0]) and 32 (CA[4:0]) bytes or whatever is set in MR0[6:5] and a fixed value of 32 bytes..

Commands other than Wrapped Read ('h8B) and Wrapped Write ('h82) are linear type bursts which allow the device to burst through page boundaries. A page boundary crossing is only available when the Burst Length Toggle is set to use MR settings (default) **AND** Burst Wrap setting is set to full page size MR0[6:5] = 11 (default). The page boundary crossing is invisible to the memory controller and limited to a lower max CLK frequency of 84MHz.

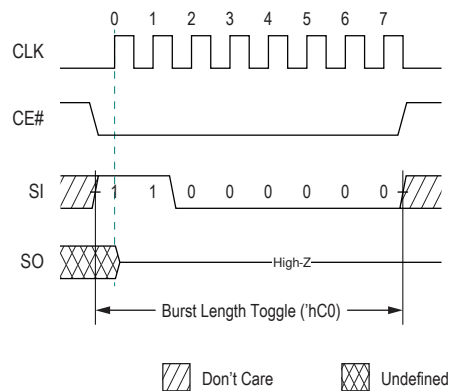

Figure 11: SPI Burst Length Toggle 'hC0

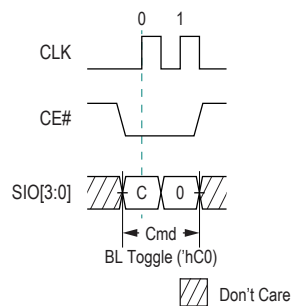

Figure 12: QPI Burst Length Toggle 'hC0

## 15 SPI Mode Operations

The device powers up into SPI mode by default but can also be switched into QPI mode.

### 15.1 SPI Read Operations

For all reads, data will be available  $t^{\text{ACLK}}$  after the falling edge of CLK.

SPI Reads can be done in four ways:

1. 'h03: Serial CMD, Serial Addr/IO, slow frequency, with wrap or linear bursting.
2. 'h0B: Serial CMD, Serial Addr/IO, fast frequency, with wrap or linear bursting.
3. 'hEB: Serial CMD, Quad Addr/IO, fast frequency, with wrap or linear bursting.
4. 'h8B: Serial CMD, Serial Addr/IO, fast frequency, with forced wrap (toggle & register configurable lengths).

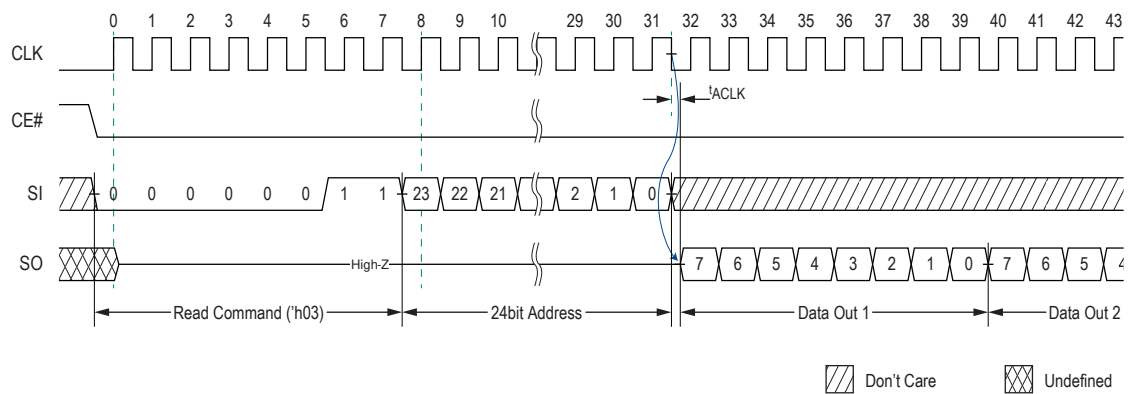

Figure 13: SPI Read 'h03 (max freq 33MHz)

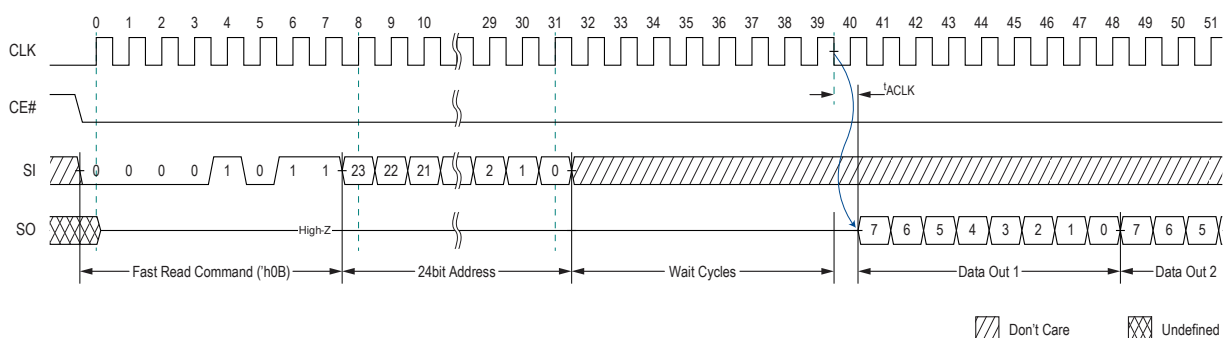

Figure 14: SPI Fast Read 'h0B (max freq 144/84 MHz)

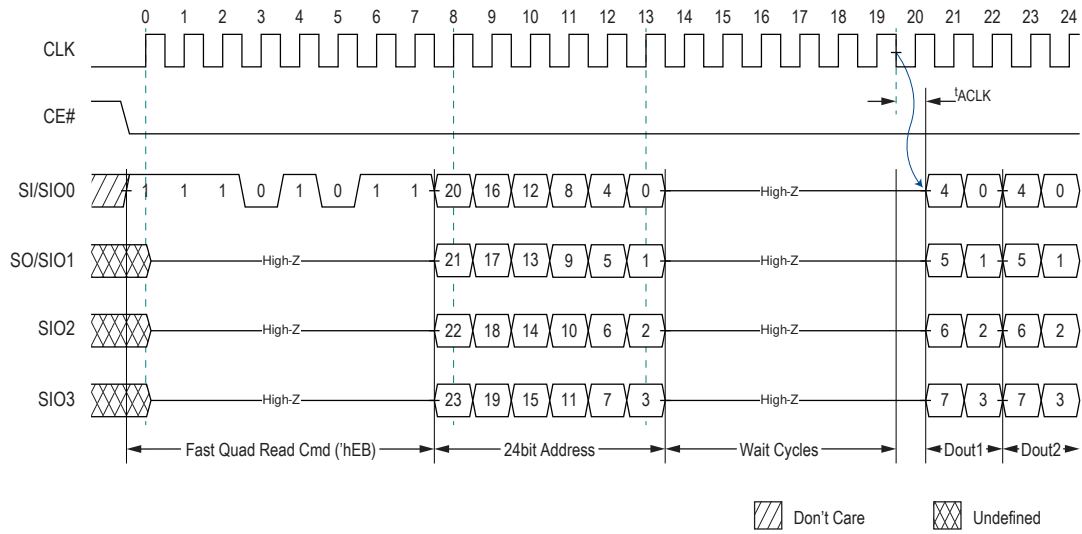

Figure 15: SPI Fast Quad Read 'hEB (max freq 144/84 MHz)

### 15.2 SPI Write Operations

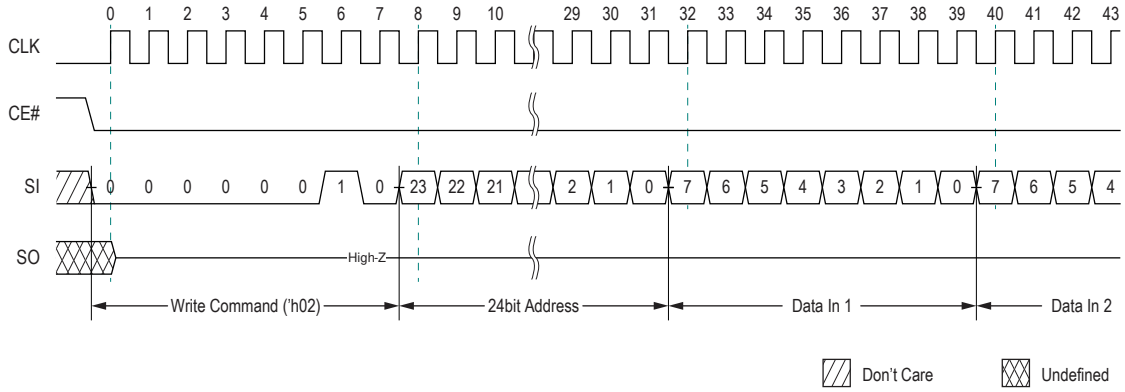

Figure 16: SPI Write 'h02

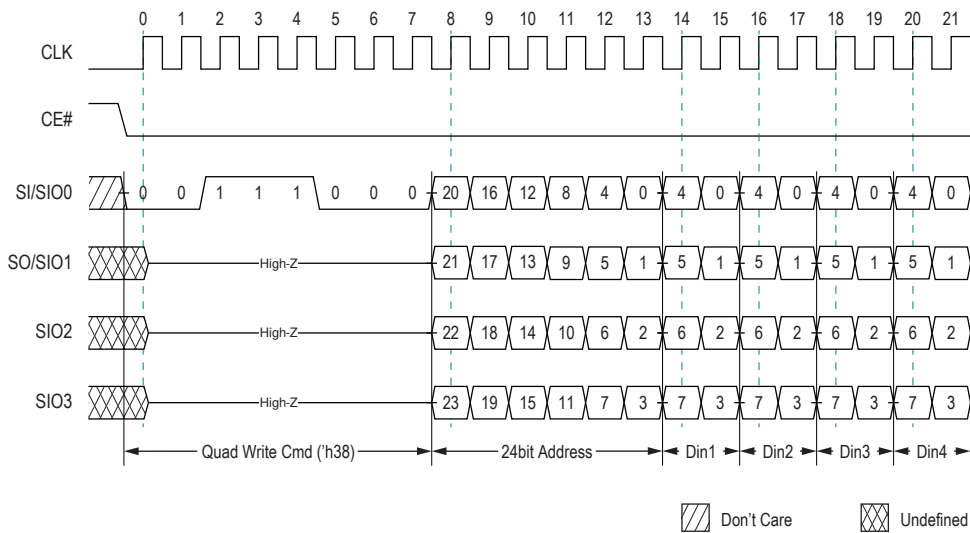
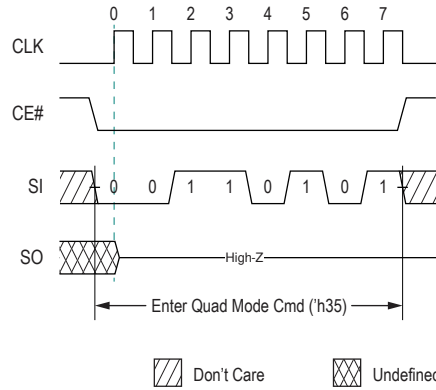

Figure 17: SPI Quad Write 'h38

### 15.3 SPI Quad Mode Enable Operation

This command switches the device into quad IO mode.



**Figure 18: Quad Mode Enable 'h35 (available only in SPI mode)**

## 16 QPI Mode Operations

### 16.1 QPI Read Operations

For all reads, data will be available  $t^*_{\text{ACLK}}$  after the falling edge of CLK.

QPI Reads can be done in one of three ways:

1. 'h0B: Quad CMD, Addr & IO, slow frequency with wrap or linear bursting.
2. 'hEB: Quad CMD, Addr & IO, fast frequency with wrap or linear bursting.
3. 'h8B: Quad CMD, Addr & IO, fast frequency with forced wrap (toggle & register configurable lengths).

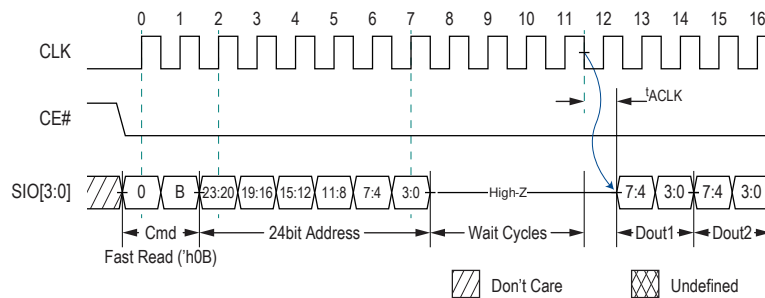

Figure 19: QPI Fast Read 'h0B (max freq 66 MHz)

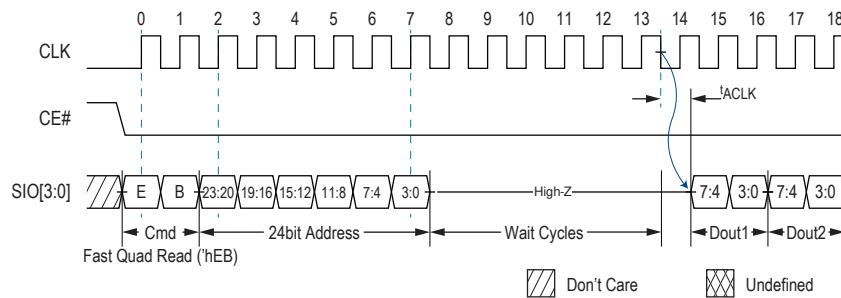

Figure 20: QPI Fast Quad Read 'hEB (max freq 144/84 MHz)

### 16.2 QPI Write Operation(s)

QPI write command can be done in one of two ways:

1. 'h02 or 'h38: Quad CMD, Addr & IO, with wrap or linear bursting.
2. 'h82: Quad CMD, Addr & IO, with forced wrap (toggle & register configurable lengths).

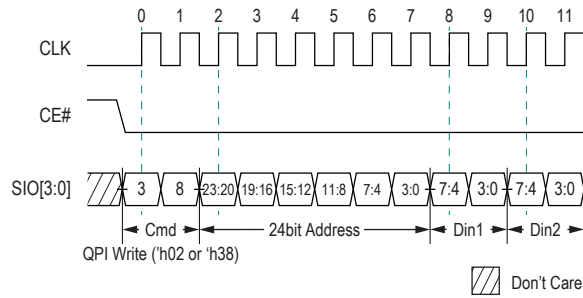

Figure 21: QPI Write

### 16.3 QPI Quad Mode Exit operation

This command will switch the device back into serial IO mode.

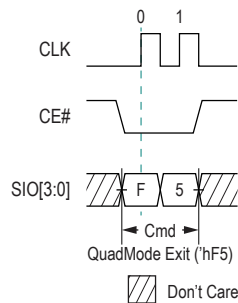

Figure 22: Quad Mode Exit 'hF5 (only available in QPI mode)



## 17 Reset Operation

The Reset operation is used as a system (software) reset that puts the device in SPI standby mode which is also the default mode after power-up. This operation consists of two commands: Reset-Enable (RSTEN) and Reset (RST).

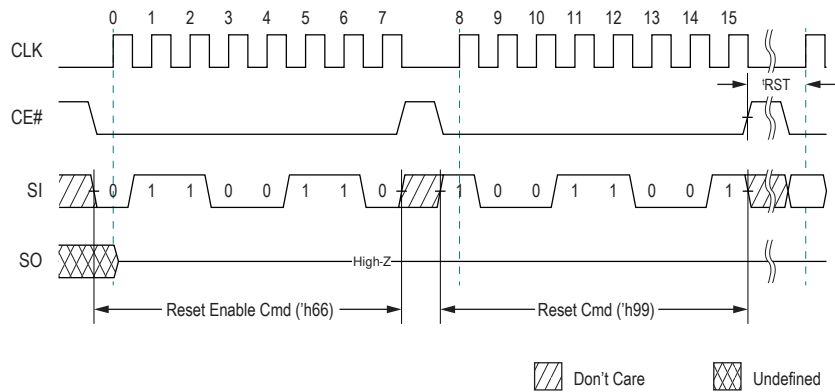

Figure 23: SPI Reset

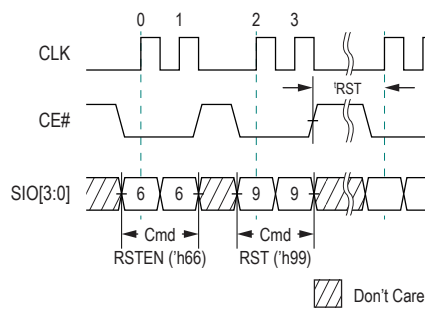

Figure 24: QPI Reset

Reset command has to immediately follow the Reset-Enable command in order for the reset operation to take effect. Any command other than the Reset command after the Reset-Enable command will cause the device to exit Reset-Enable state and abandon reset operation.

### 18 Input/Output Timing

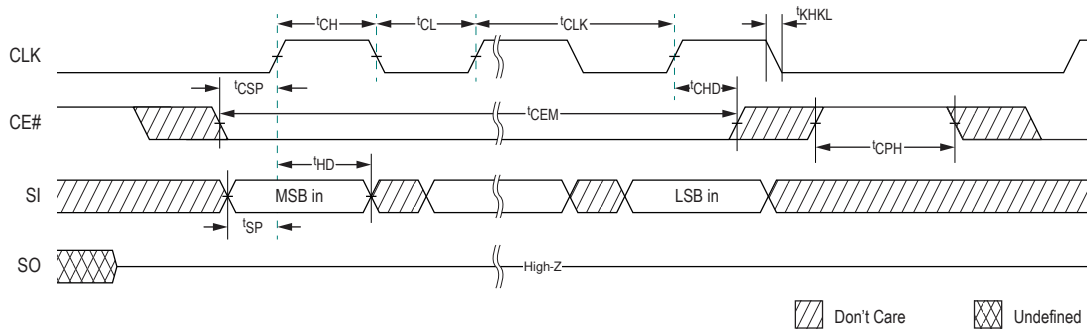

Figure 25: Input Timing

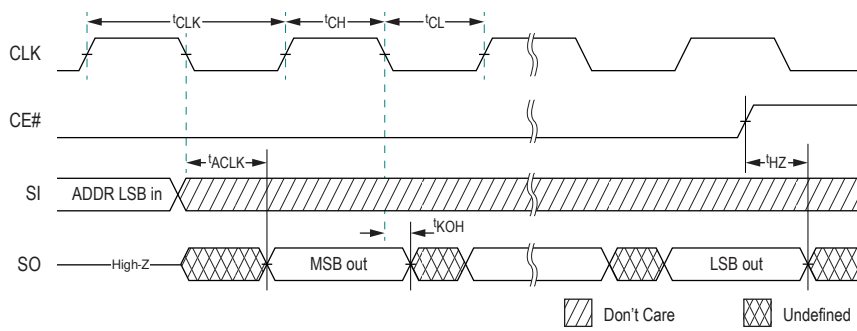

Figure 26: Output Timing

## 19 Electrical Specifications:

### 19.1 Absolute Maximum Ratings

**Table 7: Absolute Maximum Ratings**

Parameter	Symbol	Rating	Unit	Notes
Voltage to any ball except $V_{DD}$ relative to $V_{SS}$	VT	-0.4 to $V_{DD}+0.4$	V	
Voltage on $V_{DD}$ supply relative to $V_{SS}$	$V_{DD}$	-0.4 to +2.45	V	
Storage Temperature	$T_{STG}$	-55 to +150	°C	1

Notes 1: Storage temperature refers to the case surface temperature on the center/top side of the PSRAM.

Caution:

Exposing the device to stress above those listed in Absolute Maximum Ratings could cause permanent damage. The device is not meant to be operated under conditions outside the limits described in the operational section of this specification. Exposure to Absolute Maximum Rating conditions for extended periods may affect device reliability.

### 19.2 Pin Capacitance

**Table 8: Bare Die Pin Capacitance**

Parameter	Symbol	Min	Max	Unit	Notes
Input Pin Capacitance	CIN		2	pF	VIN=0V
Output Pin Capacitance	COUT		3	pF	VOUT=0V

Note 1: spec'd at 25°C.

**Table 9: Package Pin Capacitance**

Parameter	Symbol	Min	Max	Unit	Notes
Input Pin Capacitance	CIN		6	pF	VIN=0V
Output Pin Capacitance	COUT		8	pF	VOUT=0V

Note 1: spec'd at 25°C.

**Table 10: Load Capacitance**

Parameter	Symbol	Min	Max	Unit	Notes
Load Capacitance	$C_L$		15	pF	

Note 1: System  $C_L$  for the use of package

### 19.3 Decoupling Capacitor Requirement

It is required to have a decoupling capacitor on VDD pin for IO switchings and psram internal transient events. A low ESR 1 $\mu$ F ceramic cap is recommended. To minimize parasitic inductance, place the cap as close to VDD pin as possible. An optional 0.1 $\mu$ F can further improve high frequency transient response.

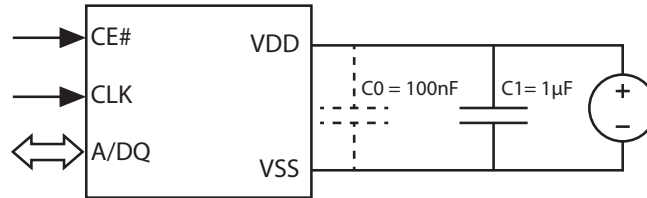

Figure 27: Decoupling Capacitor

Note that the length of grounding connection between PSRAM and PCB must be as short as possible. Having **ground plane on PCB** and **multipoint ground** would be preferred (to avoid single-point grounding topology). The width of VDD and VSS traces would be suggested more than 20mil.

### 19.4 Operating Conditions

Table 11: Operating Characteristics

Parameter	Min	Max	Unit	Notes
Operating Temperature (extended)	-40	105	°C	1
Operating Temperature (standard)	-40(-25*)	85	°C	*varies by package type

Note 1: spec'd temp range of -40 to 105°C is only characterized; test condition will be -32 to 105°C.

## 19.5 DC Characteristics

**Table 12: DC Characteristics**

Symbol	Parameter	Min	Max	Unit	Notes
V <sub>DD</sub>	Supply Voltage	1.62	1.98	V	
V <sub>IH</sub>	Input high voltage	V <sub>DD</sub> -0.4	V <sub>DD</sub> +0.2	V	
V <sub>IL</sub>	Input low voltage	-0.2	0.4	V	
V <sub>OH</sub>	Output high voltage (I <sub>OH</sub> =-0.2mA)	0.8 V <sub>DD</sub>		V	
V <sub>OL</sub>	Output low voltage (I <sub>OL</sub> =+0.2mA)		0.2 V <sub>DD</sub>	V	
I <sub>LI</sub>	Input leakage current		1	μA	
I <sub>LO</sub>	Output leakage current		1	μA	
I <sub>CC</sub>	Read/Write (144MHz)		7	mA	1,2
	Read/Write (66MHz)		6	mA	1,2
	Read/Write (13MHz)		5	mA	1,2
ISB <sub>EXT</sub>	Standby current (extended temp)		150	μA	3
ISB <sub>STD</sub>	Standby current (standard temp)		100	μA	3
ISB <sub>STDRoom</sub>	Standby current (standard room temp)		25	μA	3,4

- Note
- 1: Output load current not included.
  - 2: Typical I<sub>CC</sub> 5mA
  - 3: Standby current is measured when CLK is in DC low state.
  - 4: Typical ISB<sub>STD</sub> 20μA at 25°C

## 19.6 AC Characteristics

Table 13: READ/WRITE Timing

Symbol	Parameter	Min	Max	Unit	Notes
t <sub>CLK</sub>	CLK period - SPI Read ('h03)	30.3		ns	33MHz
	CLK period - QPI Read ('h0B)	15.1			66MHz
	CLK period - all other operations	7			144MHz <sup>*1,2,3</sup>
t <sub>CH</sub> /t <sub>CL</sub>	Clock high/low width	0.45	0.55	t <sub>CLK</sub> (min)	
t <sub>KHKL</sub>	CLK rise or fall time		1.1	ns	4
t <sub>CPH</sub>	CE# HIGH between subsequent burst operations	18		ns	
t <sub>CEM</sub>	CE# low pulse width		4	μs	Extended grade
			8		Standard grade
t <sub>CSP</sub>	CE# setup time to CLK rising edge PKG	2.5		ns	2
t <sub>CHD</sub>	CE# hold time from CLK rising edge PKG	3		ns	2
t <sub>SP</sub>	Setup time to active CLK edge	2		ns	
t <sub>HD</sub>	Hold time from active CLK edge	2		ns	
t <sub>HZ</sub>	Chip disable to DQ output high-Z		6	ns	
t <sub>ACLK</sub>	CLK to output delay	2	5.5	ns	3
t <sub>KOH</sub>	Data hold time from clock falling edge	1.5		ns	
t <sub>RST</sub>	Time between end of RST CMD to next valid CMD	50		ns	

Note 1: Only Linear 512 Burst allows page boundary crossing. Frequency limits are therefore 144MHz max for Wrapped Burst operation, 84MHz max when Linear 512 Burst commands cross page boundary

2: System max C<sub>L</sub> 15pF for the use of package.

3: For operating frequencies >84MHz, it is highly recommended to utilize CLK falling edge to sample read data or align sampling clock via data pattern tuning (refer to JEDEC JESD84-B50 for an example).

4: Measured from 20% to 80% of VDD