

RoHS Compliant

## Serial ATA Flash Drive

SM210-297 High-Speed Product Specifications

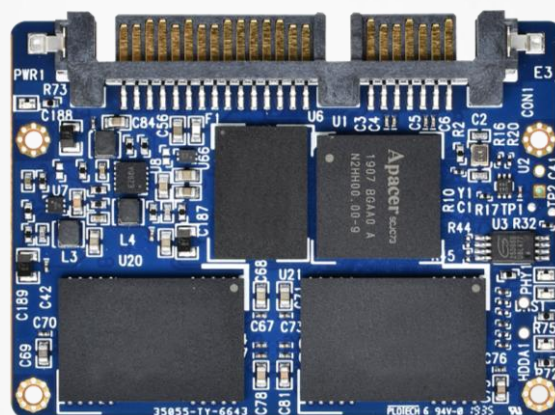

February 24, 2020

Version 1.3



**Apacer Technology Inc.**

1F, No.32, Zhongcheng Rd., Tucheng Dist., New Taipei City, Taiwan, R.O.C

Tel: +886-2-2267-8000 Fax: +886-2-2267-2261

[www.apacer.com](http://www.apacer.com)

## Specifications Overview:

- **Compliance with SATA Revision 3.1**
  - SATA 6 Gb/s interface
  - Backward compatible with SATA 1.5 and 3 Gb/s interfaces
  - ATA-8 command set
- **Capacity**
  - 32, 64, 128, 256, 512 GB
- **Performance\***
  - Burst read/write: 600 MB/sec
  - Sequential read: up to 545 MB/sec
  - Sequential write: up to 490 MB/sec
  - Random read (4K): up to 82,000 IOPS
  - Random write (4K): up to 78,000 IOPS
- **Flash Management**
  - Built-in hardware ECC
  - Global Wear Leveling
  - Flash bad-block management
  - S.M.A.R.T.
  - Power Failure Management
  - Device Sleep
  - ATA Secure Erase
  - TRIM
- **SATA Power Management**
- **NAND Flash Type:** MLC
- **MTBF:** >1,000,000 hours
- **Endurance (in Terabytes Written: TBW)**
  - 32 GB: 60 TBW
  - 64 GB: 133 TBW
  - 128 GB: 279 TBW
  - 256 GB: 604 TBW
  - 512 GB: 586 TBW
- **Temperature Range**
  - Operating:
    - Standard: 0°C to 70°C
    - Wide: -40°C to 85°C
  - Storage: -40°C to 100°C
- **Supply Voltage**
  - 5.0 V ± 5%
- **Power Consumption\***
  - Active mode: 825 mA
  - Idle mode: 80 mA
- **Connector Type**
  - 7-pin SATA signal connector
  - 15-pin SATA power connector
- **Form Factor**
  - JEDEC MO-297
  - Dimensions: 54.0 x 39.8 x 4.0, unit: mm
- **Shock & Vibration\*\***
  - Shock: 1,500 G
  - Vibration: 15 G
- **Reliability**
  - Thermal Sensor
- **DRAM Cache for Enhanced Random Performance**
- **RoHS Compliant**

\*Varies from capacities. The values for performances and power consumptions presented are typical and may vary depending on flash configurations or platform settings. Power consumption results of 128/256GB were based on experimental estimations.  
 \*\*Non-operating

## Table of Contents

<b>1. Product Description .....</b>	<b>4</b>
1.1 Introduction .....	4
1.2 Capacity .....	4
1.3 Performance .....	4
1.4 Pin Assignments .....	5
<b>2. Software Interface .....</b>	<b>7</b>
2.1 Command Set .....	7
2.2 S.M.A.R.T. ....	7
<b>3. Flash Management .....</b>	<b>9</b>
3.1 Error Correction/Detection .....	9
3.2 Bad Block Management .....	9
3.3 Global Wear Leveling .....	9
3.4 Power Failure Management .....	9
3.5 ATA Secure Erase .....	9
3.6 TRIM .....	10
3.7 DEVSLP (DevSleep or DEVSLP) Mode .....	10
3.8 SATA Power Management .....	10
<b>4. Reliability Features .....</b>	<b>11</b>
4.1 Thermal Sensor .....	11
<b>5. Environmental Specifications.....</b>	<b>12</b>
5.1 Environmental.....	12
5.2 Mean Time Between Failures (MTBF) .....	12
5.3 Certification and Compliance.....	12
5.4 Endurance .....	13
<b>6. Electrical Specifications .....</b>	<b>14</b>
6.1 Operating Voltage.....	14
6.2 Power Consumption .....	14
<b>7. Physical Characteristics.....</b>	<b>15</b>
<b>8. Product Ordering Information.....</b>	<b>16</b>
8.1 Product Code Designations.....	16

8.2 Valid Combinations..... 17

# 1. Product Description

## 1.1 Introduction

Apacer's SM210-297 is a well-balanced solid-state disk (SSD) drive with compact form factor and great performance. Designed in SATA 6 Gb/s interface, the SSD is able to deliver exceptional read/write speed, making it the ideal companion for heavy-loading industrial or server operations.

For data efficiency, the internal controlling unit of the SSD is engineered with DRAM for enhanced random performance. In regard of reliability, the drive comes with various implementations including powerful hardware ECC engine, power saving modes, wear leveling, flash block management, S.M.A.R.T., TRIM, and power failure management.

## 1.2 Capacity

Capacity specifications of SM210-297 are available as shown in Table 1-1. It lists the specific capacity and the default numbers of heads, sectors and cylinders for each product line.

**Table 1-1 Capacity Specifications**

Capacity	Total bytes*	Cylinders	Heads	Sectors	Max LBA
32 GB	32,017,047,552	16,383	16	63	62,533,296
64 GB	64,023,257,088	16,383	16	63	125,045,424
128 GB	128,035,676,160	16,383	16	63	250,069,680
256 GB	256,060,514,304	16,383	16	63	500,118,192
512 GB	512,110,190,592	16,383	16	63	1,000,215,216

\*Display of total bytes varies from file systems, which means not all of the bytes can be used for storage.

\*\*Notes: 1 GB = 1,000,000,000 bytes; 1 sector = 512 bytes.

LBA count addressed in the table above indicates total user storage capacity and will remain the same throughout the lifespan of the device. However, the total usable capacity of the SSD is most likely to be less than the total physical capacity because a small portion of the capacity is reserved for device maintenance usages.

## 1.3 Performance

Performance of SM210-297 is listed below in Table 1-2.

**Table 1-2 Performance Specifications**

Performance	Capacity	32 GB	64 GB	128 GB	256 GB	512 GB
	<b>Sequential Read* (MB/s)</b>		400	540	545	545
<b>Sequential Write* (MB/s)</b>		100	205	180	350	490
<b>Random Read IOPS** (4K)</b>		48,000	77,000	76,000	82,000	56,000
<b>Random Write IOPS** (4K)</b>		24,000	50,000	44,000	78,000	29,000

Note:

Results may differ from various flash configurations or host system setting.

\*Sequential performance is based on CrystalDiskMark 5.2.1 with file size 1,000MB.

\*\*Random performance measured using IOMeter with Queue Depth 32.

## 1.4 Pin Assignments

Table 1-3 describes the SFD signal segment and Table1-4 for power segment.

**Figure 1-1** SATA Connectors

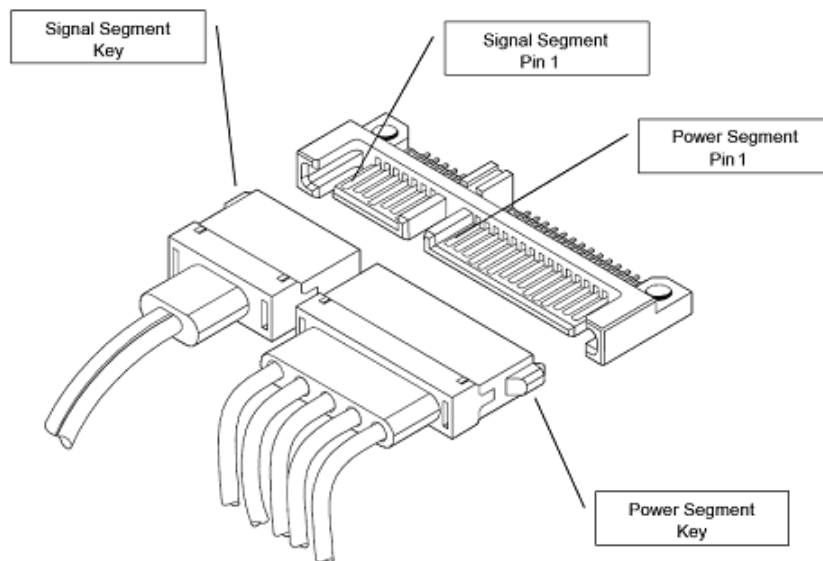
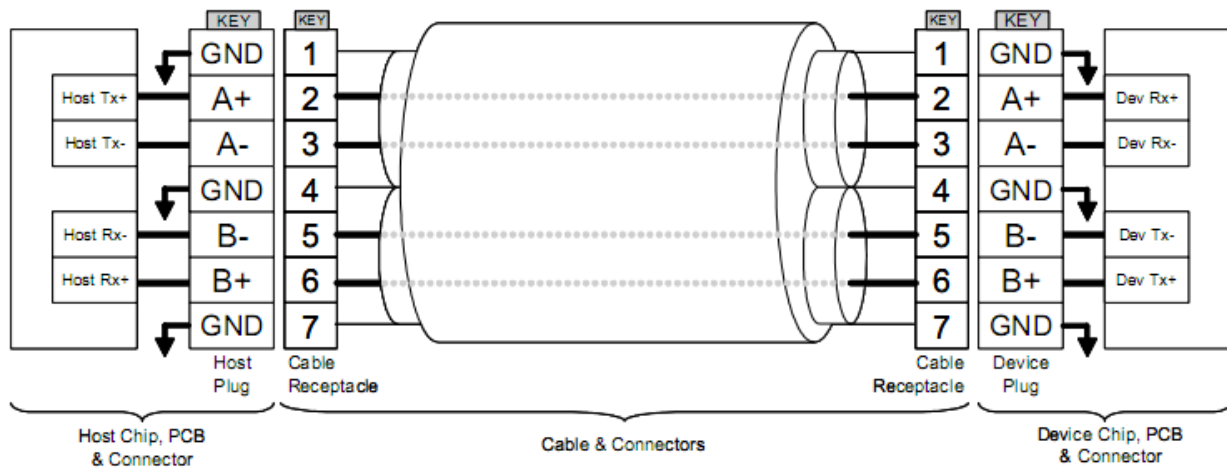

**Table 1-3** Signal Segment

Pin	Type	Description
S1	GND	
S2	RxP	+ Differential Receive
S3	RxN	- Differential Receive
S4	GND	
S5	TxN	- Differential Transmit
S6	TxP	+ Differential Transmit
S7	GND	

**Table 1-4** Power Segment

Pin	Signal/Description
Pin1	Unused (3.3V)
Pin2	Unused (3.3V)
Pin3	Device Sleep
Pin4	Ground
Pin5	Ground
Pin6	Ground
Pin7	5V
Pin8	5V
Pin9	5V
Pin10	Ground
Pin11	DAS
Pin12	Ground
Pin13	Unused (12V)
Pin14	Unused (12V)
Pin15	Unused (12V)



**Figure 1-2** SATA Cable/Connector Connection Diagram

The connector on the left represents the Host with TX/RX differential pairs connected to a cable. The connector on the right shows the Device with TX/RX differential pairs also connected to the cable. Notice also the ground path connecting the shielding of the cable to the Cable Receptacle.

## 2. Software Interface

### 2.1 Command Set

Table 2-1 summarizes the ATA commands supported by SM210-297.

**Table 2-1** Command Set

Code	Command	Code	Command
E5h	CHECK POWER MODE	F6h	SECURITY DISABLE
90h	EXECUTE DIAGNOSTICS	F3h	SECURITY ERASE
E7h	FLUSH CACHE	F4h	SECURITY ERASE UNIT
ECh	IDENTIFY DEVICE	F5h	SECURITY FREEZE LOCK
E3h	IDLE	F1h	SECURITY SET PASSWORD
E1h	IDLE IMMEDIATE	F2h	SECURITY UNLOCK
91h	INITIALIZE DEVICE PARAMETERS	7Xh	SEEK
C8h	READ DMA	EFh	SET FEATURES
25h	READ DMA EXT	C6h	SET MULTIPLE MODE
60h	READ FPDMA QUEUED	E6h	SLEEP
47h	READ LOG DMA EXT	B0h	S.M.A.R.T.
2Fh	READ LOG EXT	E2h	STANDBY
C4h	READ MULTIPLE	E0h	STANDBY IMMEDIATE
20 or 21h	READ SECTOR(S)	CAh	WRITE DMA
40 or 41h	READ VERIFY SECTOR(S)	35h	WRITE DMA EXT
10h	RECALIBRATE	61h	WRITE FPDMA QUEUED
57h	WRITE LOG DMA EXT	3Fh	WRITE LOG EXT
C5h	WRITE MULTIPLE	30h or 31h	WRITE SECTOR(S)

### 2.2 S.M.A.R.T.

S.M.A.R.T. is an abbreviation for Self-Monitoring, Analysis and Reporting Technology, a self-monitoring system that provides indicators of drive health as well as potential disk problems. It serves as a warning for users from unscheduled downtime by monitoring and displaying critical drive information. Ideally, this should allow taking proactive actions to prevent drive failure and make use of S.M.A.R.T. information for future product development reference.

Apacer devices use the standard SMART command B0h to read data out from the drive to activate our S.M.A.R.T. feature that complies with the ATA/ATAPI specifications. S.M.A.R.T. Attribute IDs shall include initial bad block count, total later bad block count, maximum erase count, average erase count, power on hours and power cycle. When the S.M.A.R.T. Utility running on the host, it analyzes and reports the disk status to the host before the device reaches in critical condition.

Note: Attribute IDs may vary from product models due to various solution design and supporting capabilities.



Apacer memory products come with S.M.A.R.T. commands and subcommands for users to obtain information of drive status and to predict potential drive failures. Users can take advantage of the following commands/subcommands to monitor the health of the drive.

Code	SMART Subcommand
D0h	READ DATA
D1h	READ ATTRIBUTE THRESHOLDS
D2h	ENABLE/DISABLE ATTRIBUTE AUTOSAVE
D4h	EXECUTE OFF-LINE IMMEDIATE
D5h	READ LOG (OPTIONAL)
D6h	WRITE LOG (OPTIONAL)
D8h	ENABLE OPERATIONS
D9h	DISABLE OPERATIONS
DAh	RETURN STATUS

### General SMART attribute structure

Byte	Description
0	ID (HEX)
1 – 2	STATUS FLAG
3	VALUE
4	WORST
5*-11	RAW DATA

\*Byte 5: LSB

### SMART attribute ID list

ID (Hex)	Attribute Name
9 (0x09)	POWER-ON HOURS
12 (0x0C)	POWER CYCLE COUNT
163 (0xA3)	MAX. ERASE COUNT
164 (0xA4)	AVG. ERASE COUNT
166 (0xA6)	TOTAL LATER BAD BLOCK COUNT
167 (0xA7)	SSD PROTECT MODE (VENDOR SPECIFIC)
168 (0xA8)	SATA PHY ERROR COUNT
175 (0xAF)	BAD CLUSTER TABLE COUNT
192 (0xC0)	UNEXPECTED POWER LOSS COUNT
194 (0xC2)	TEMPERATURE
241 (0xF1)	TOTAL SECTORS OF WRITE

## 3. Flash Management

### 3.1 Error Correction/Detection

SM210-297 implements a hardware ECC scheme, based on the BCH algorithm. It can detect and correct up to 40 bits error in 1K bytes.

### 3.2 Bad Block Management

Current production technology is unable to guarantee total reliability of NAND flash memory array. When a flash memory device leaves factory, it comes with a minimal number of initial bad blocks during production or out-of-factory as there is no currently known technology that produce flash chips free of bad blocks. In addition, bad blocks may develop during program/erase cycles. When host performs program/erase command on a block, bad block may appear in Status Register. Since bad blocks are inevitable, the solution is to keep them in control. Apacer flash devices are programmed with ECC, page mapping technique and S.M.A.R.T to reduce invalidity or error. Once bad blocks are detected, data in those blocks will be transferred to free blocks and error will be corrected by designated algorithms.

### 3.3 Global Wear Leveling

Flash memory devices differ from Hard Disk Drives (HDDs) in terms of how blocks are utilized. For HDDs, when a change is made to stored data, like erase or update, the controller mechanism on HDDs will perform overwrites on blocks. Unlike HDDs, flash blocks cannot be overwritten and each P/E cycle wears down the lifespan of blocks gradually. Repeatedly program/erase cycles performed on the same memory cells will eventually cause some blocks to age faster than others. This would bring flash storages to their end of service term sooner. Global wear leveling is an important mechanism that levels out the wearing of all blocks so that the wearing-down of all blocks can be almost evenly distributed. This will increase the lifespan of SSDs.

### 3.4 Power Failure Management

Power Failure Management plays a crucial role when power supply becomes unstable. Power disruption may occur when users are storing data into the SSD, leading to instability in the drive. However, with Power Failure Management, a firmware protection mechanism will be activated to scan pages and blocks once power is resumed. Valid data will be transferred to new blocks for merging and the mapping table will be rebuilt. Therefore, data reliability can be reinforced, preventing damage to data stored in the NAND Flash.

Note: The controller unit of this product model is designed with a DRAM as a write cache for improved performance and data efficiency. Though unlikely to happen in most cases, the data cached in the volatile DRAM might be potentially affected if a sudden power loss takes place before the cached data is flushed into non-volatile NAND flash memory.

### 3.5 ATA Secure Erase

ATA Secure Erase is an ATA disk purging command currently embedded in most of the storage drives. Defined in ATA specifications, (ATA) Secure Erase is part of Security Feature Set that allows storage drives to erase all user data areas. The erase process usually runs on the firmware level as most of the ATA-based storage media currently in the market are built-in with this command. ATA Secure Erase can securely wipe out the user data in the drive and protects it from malicious attack.

### 3.6 TRIM

TRIM is a SATA command that helps improve the read/write performance and efficiency of solid-state drives (SSD). The command enables the host operating system to inform SSD controller which blocks contain invalid data, mostly because of the erase commands from host. The invalid will be discarded permanently and the SSD will retain more space for itself.

### 3.7 DEVSLP (DevSleep or DEVSLP) Mode

Device Sleep is a feature that allows SATA devices to enter a low power mode by designating a particular pin as DEVSLP signal with an aim to reducing power consumption.

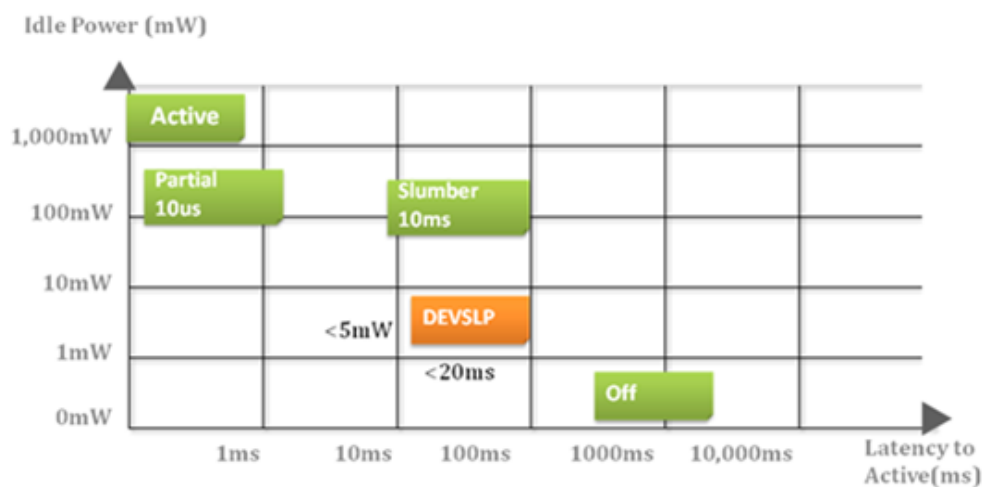

### 3.8 SATA Power Management

By complying with SATA 6 Gb/s specifications, the SSD supports the following SATA power saving modes:

- ACTIVE: PHY ready, full power, Tx & Rx operational
- PARTIAL: Reduces power, resumes in under 10  $\mu$ s (microseconds)
- SLUMBER: Reduces power, resumes in under 10 ms (milliseconds)
- HIPM: Host-Initiated Power Management
- DIPM: Device-Initiated Power Management
- AUTO-SLUMBER: Automatic transition from partial to slumber
- Device Sleep (DevSleep or DEVSLP): PHY powered down; power consumption  $\leq 5$  mW; host assertion time  $\leq 10$  ms; exit timeout from this state  $\leq 20$  ms (unless specified otherwise in SATA Identify Device Log).

Note: The behaviors of power management features would depend on host/device settings.

## 4. Reliability Features

### 4.1 Thermal Sensor

Apacer Thermal Sensor is a digital temperature sensor with serial interface. By using a designated pin for transmission, storage device owners are able to read temperature data.

## 5. Environmental Specifications

### 5.1 Environmental

SM210-297 environmental specifications follow the US military standards, shown in the table below.

**Table 5-1** Environmental Specifications

Environment	Specifications
Temperature	0°C to 70°C (Standard); -40°C to 85°C (Wide)
	-40°C to 100°C (Non-operating)
Vibration	Non-operating: Sine wave, 15(G), 10~2000(Hz), Operating: Random, 7.69(Grms), 20~2000(Hz)
Shock	Non-operating: Acceleration, 1,500 G, 0.5 ms Operating: Peak acceleration, 50 G, 11 ms

### 5.2 Mean Time Between Failures (MTBF)

Mean Time Between Failures (MTBF) is predicted based on reliability data for the individual components in SM210-297. The prediction result for SM210-297 is more than 1,000,000 hours.

Note: The MTBF is predicated and calculated based on “Telcordia Technologies Special Report, SR-332, Issue 2” method.

### 5.3 Certification and Compliance

SM210-297 complies with the following standards:

- CE
- FCC
- RoHS
- MIL-STD-810F

## 5.4 Endurance

The endurance of a storage device is predicted by TeraBytes Written based on several factors related to usage, such as the amount of data written into the drive, block management conditions, and daily workload for the drive. Thus, key factors, such as Write Amplifications and the number of P/E cycles, can influence the lifespan of the drive.

**Table 5-2** Endurance Specifications

Capacity	TeraBytes Written
32 GB	60
64 GB	133
128 GB	279
256 GB	604
512 GB	586

Note:

- The measurement assumes the data written to the SSD for test is under a typical and constant rate.
- The measurement follows the standard metric: 1 TB (Terabyte) = 1,000 GB.
- This estimation complies with JEDEC JESD-219, enterprise endurance workload of random data with payload size distribution.

## 6. Electrical Specifications

### 6.1 Operating Voltage

Table 6-1 lists the supply voltage for SM210-297.

**Table 6-1** Operating Range

Item	Range
Supply Voltage	5V $\pm$ 5% (4.75-5.25V)

### 6.2 Power Consumption

Table 6-2 lists the power consumption for SM210-297.

**Table 6-2** Power Consumption

Capacity Mode	32 GB	64 GB	128 GB	256 GB	512 GB
Active (mA)	235	320	325	515	825
Idle (mA)	80	80	80	80	80

Note:

\*All values are typical and may vary depending on flash configurations or host system settings.

\*\*Active power is an average power measurement performed using CrystalDiskMark with 128KB sequential read/write transfers.

## 7. Physical Characteristics

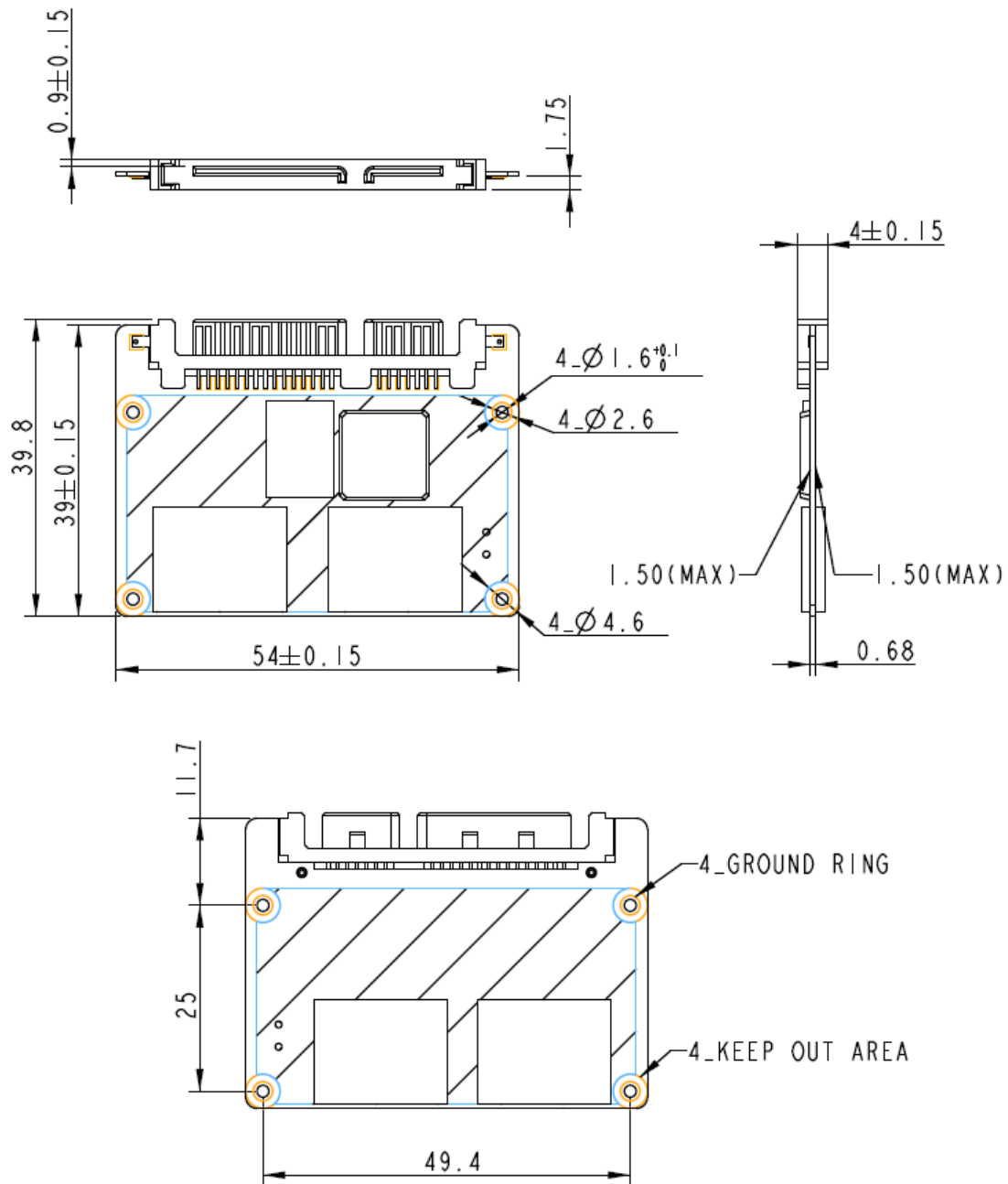



## 8. Product Ordering Information

### 8.1 Product Code Designations

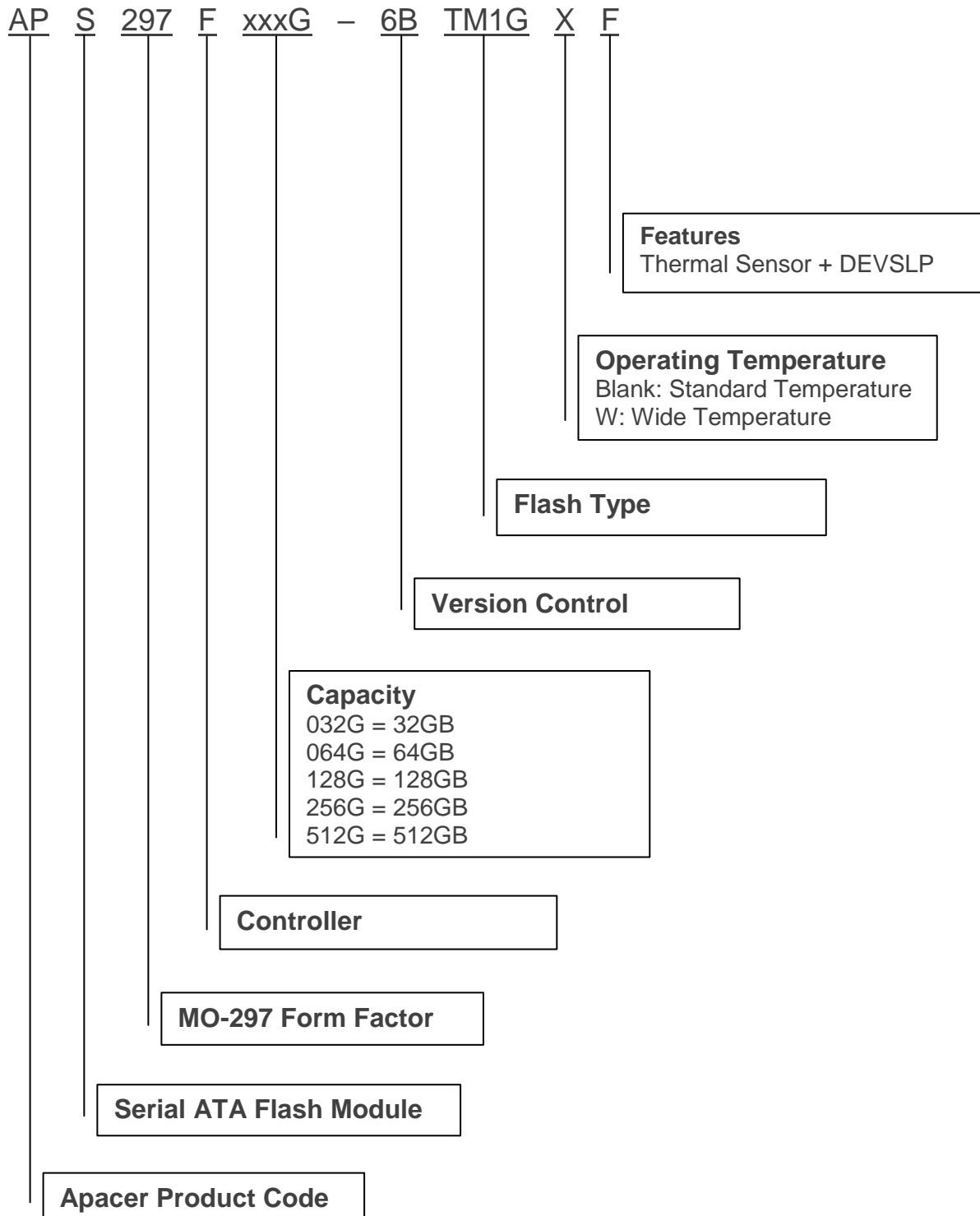

## 8.2 Valid Combinations

Capacity	Standard Temperature	Wide Temperature
32GB	APS297F032G-6BTM1GF	APS297F032G-6BTM1GWF
64GB	APS297F064G-6BTM1GF	APS297F064G-6BTM1GWF
128GB	APS297F128G-6BTM1GF	APS297F128G-6BTM1GWF
256GB	APS297F256G-6BTM1GF	APS297F256G-6BTM1GWF
512GB	APS297F512G-6BTM1GF	APS297F512G-6BTM1GWF

**Note:** Valid combinations are those products in mass production or will be in mass production. Consult your Apacer sales representative to confirm availability of valid combinations and to determine availability of new combinations.

## Revision History

Revision	Description	Date
1.0	Official release	6/14/2018
1.1	Revised the description of 4.1 Thermal Sensor	7/3/2018
1.2	<ul style="list-style-type: none"><li>- Renamed extended temperature to wide temperature</li><li>- Updated sequential read/write performance with that tested at QD32 for Performance on Specifications Overview and 1.3 Performance</li><li>- Updated technology description for 3.4 Power Failure Management</li><li>- Added 3.7 DEVSLP (DevSleep or DEVSLP) Mode</li><li>- Updated Power Consumption on Specifications Overview page and 6.2 Power Consumption</li></ul>	12/10/2019
1.3	Updated product photo on the cover page	2/24/2020