

SPI/QPI PSRAM

Specifications

- **Single Supply Voltage**
 - VDD=1.62 to 1.98V
- **Interface:** SPI/QPI with SDR mode
- **Performance:** Clock rate up to 84MHz
- **Organization:** 64Mb, 8M x 8bits
- **Addressable Bit Range:** A[22:0]
- **Page Size:** 1024 bytes
- **Refresh:** Self-managed
- **Operating Temperature Range**
 - TC = -40°C to +85°C (standard range)
 - TC = -40°C to +105°C (extended range)
- **Maximum Standby Current**
 - 300µA @ 105°C
 - 200µA @ 85°C
 - 100µA @ 25°C
 - 30µA @ 25°C (Half Sleep Mode with data retention)

Features

- **50Ω Output Drive Strength LVCMOS.**
- **Linear Burst** is supported up to 84MHz and can cross page boundary as long as tCEM is met.
- **Software Reset**
- **Ultra Low Power Half Sleep Mode** with data retention.

Table of Contents

1 Table of Contents

1	Table of Contents	2
2	Introduction	4
3	Package Information	4
4	Package Outline Drawing	5
4.1	SOP-8L(150), package code SN	5
4.2	USON-8L 3x2mm, package code ZR	6
5	Ordering Information	7
6	Signal Table	8
7	Power-Up Initialization	8
8	Interface Description	9
8.1	Address Space	9
8.2	Page Size	9
8.3	Drive Strength	9
8.4	Power-on Status	9
8.5	Command/Address Latching Truth Table	10
8.6	Command Termination	11
9	Half Sleep mode Operation	12
10	SPI Mode Operations	13
10.1	SPI Read Operations	13
10.2	SPI Write Operations	15
10.3	SPI Quad Mode Enable Operation	16
10.4	SPI Read ID Operation	16
11	QPI Mode Operations	17
11.1	QPI Read Operation	17
11.2	QPI Write Operation(s)	18
11.3	QPI Quad Mode Exit operation	18
12	Reset Operation	19
13	Input/Output Timing	20

14	Electrical Specifications:	21
14.1	Absolute Maximum Ratings	21
14.2	Pin Capacitance	21
14.3	Decoupling Capacitor Requirement.....	22
14.4	Operating Conditions	22
14.5	DC Characteristics	23
14.6	AC Characteristics	24
15	Change Log.....	25

2 Introduction

This Pseudo-SRAM device features a high speed, low pin count interface. It has 4 SDR I/O pins and operates in SPI(serial peripheral interface) or QPI (quad peripheral interface) mode with frequencies up to 84 MHz. The data input (A/DQ) to the memory relies on clock (CLK) to latch all instructions, addresses and data. It is most suitable for low-power and low cost portable applications. It incorporates a seamless self-managed refresh mechanism. Hence it does not require the support of DRAM refresh from system host. The self-refresh feature is a special design to maximize performance of memory read operation.

3 Package Information

The APS6404L-SQRH is available in standard package including 8-lead SOP-8L(150) and advanced package including 8-lead , USON-8L 3x2mm.

- **Package Type: SOP/USON (SN, ZR)**

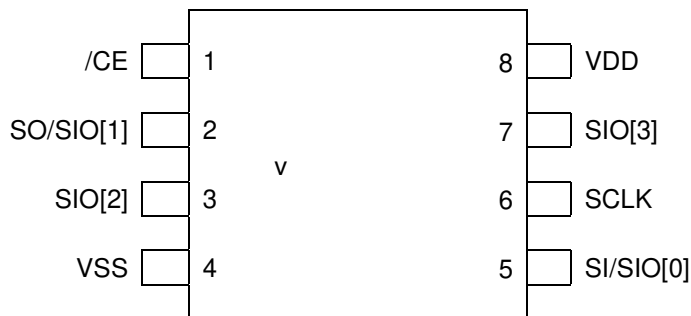

Top View

4 Package Outline Drawing

4.1 SOP-8L(150), package code SN

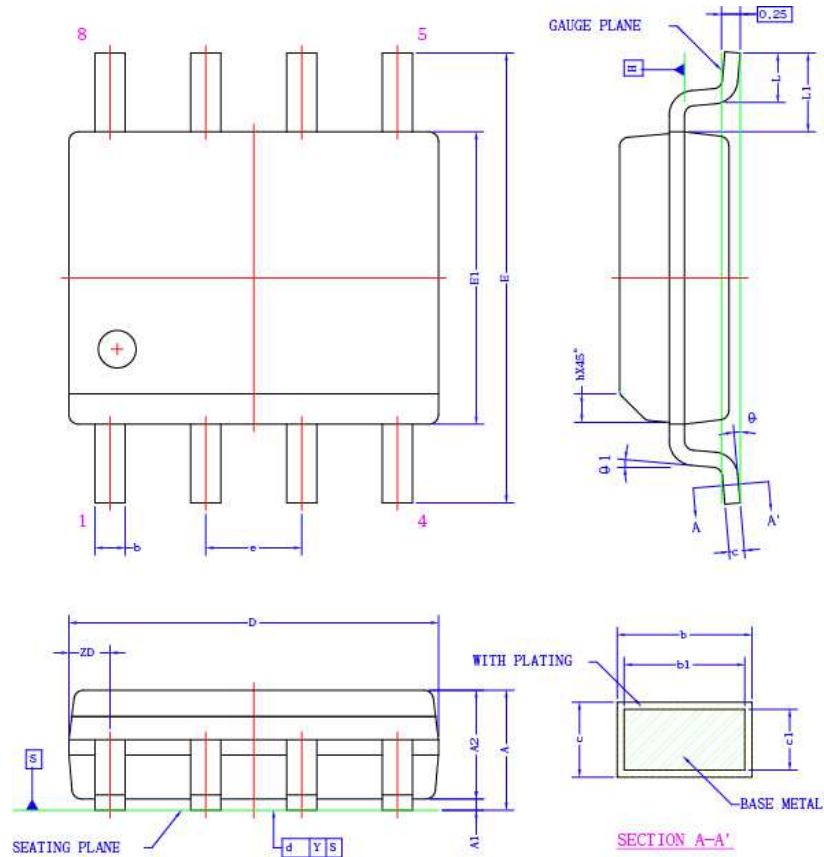

SYMBOL	DIMENSION (MM)			DIMENSION (MIL)		
	MIN.	NOM.	MAX.	MIN.	NOM.	MAX.
A	1.35	1.60	1.75	53	63	69
A1	0.10	0.15	0.25	4	6	10
A2	1.35	1.45	1.55	53	57	61
b	0.31	-	0.51	12	-	20
b1	0.28	0.40	0.48	11	16	19
c	0.17	-	0.25	7	-	10
c1	0.17	0.20	0.23	7	8	9
D	4.80	4.90	5.00	189	193	197
E	6.00 BSC			236 BSC		
E1	3.80	3.90	4.00	150	154	157
e	1.27 BSC			50 BSC		
L	0.40	0.66	1.27	16	26	50
L1	1.05 REF			41 REF		
ZD	0.55 REF			22 REF		
h	0.25	0.38	0.50	10	15	20
Y	-	-	0.10	-	-	4
ϕ	0°	-	8°	0°	-	8°
$\phi 1$	0°	-	-	0°	-	-

NOTE :

- REFER TO JEDEC STD: MS-012 AA.
- DIMENSION 'D' DOES NOT INCLUDE MOLD FLASH, PROTRUSION OR GATE BURRS. MOLD FLASH, PROTRUSION AND GATE BURRS SHALL NOT EXCEED 0.15mm PER SIDE.
DIMENSION 'E1' DOES NOT INCLUDE INTERLEAD MOLD FLASH OR PROTRUSION. INTERLEAD MOLD FLASH OR PROTRUSION SHALL NOT EXCEED 0.25mm PER SIDE.
'D' AND 'E1' DIMENSIONS ARE DETERMINED AT DATUM H.
- DIMENSION 'b' DOES NOT INCLUDE DAMBAR PROTRUSION. ALLOWABLE DAMBAR PROTRUSION SHALL BE 0.10mm TOTAL IN EXCESS OF THE 'b' DIMENSION AT MAXIMUM MATERIAL CONDITION. THE DAMBAR CANNOT BE LOCATED ON THE LOWER RADIUS OF THE FOOT.

4.2 USON-8L 3x2mm, package code ZR

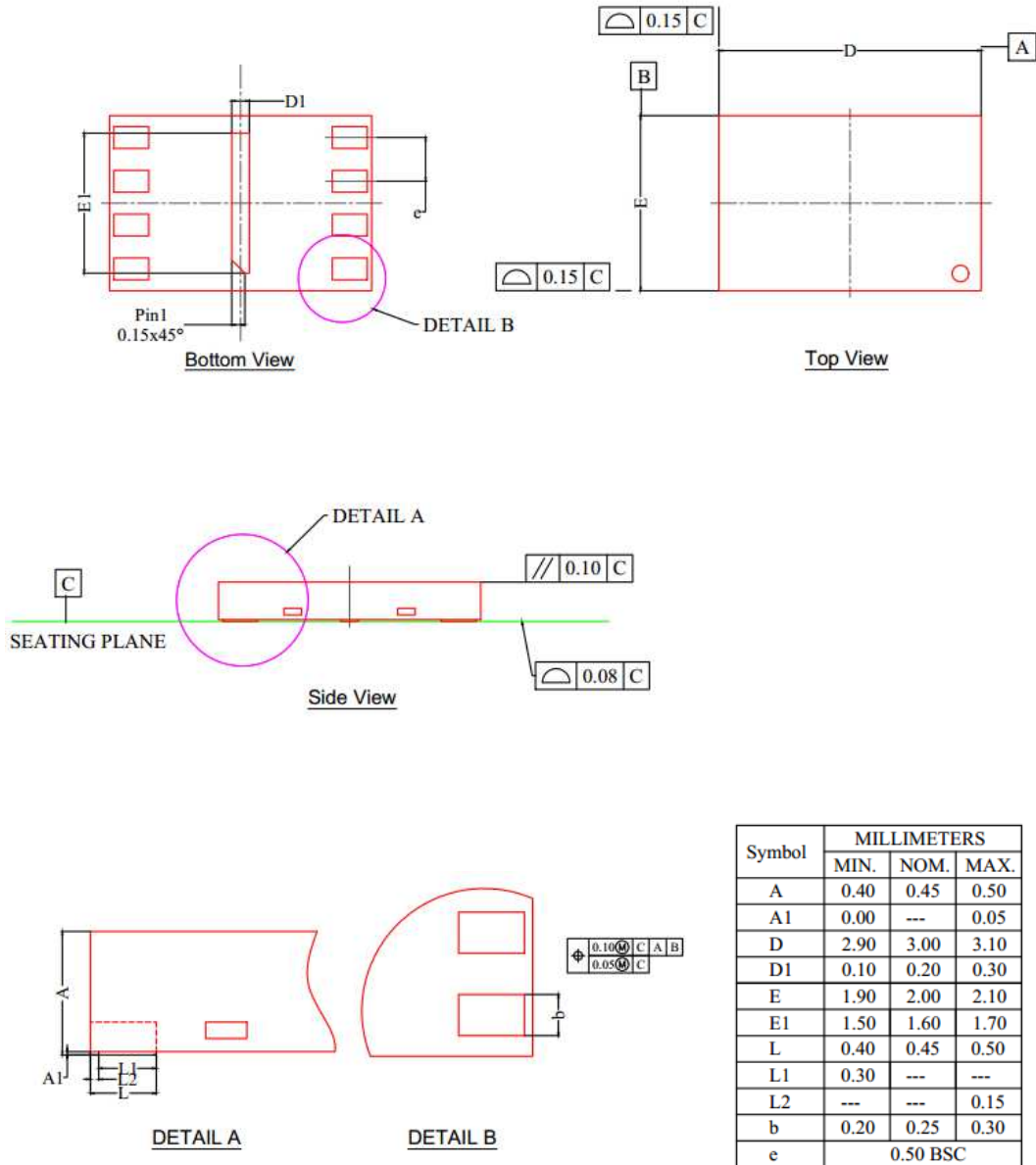

NOTE:

1. Scale 1:4
2. ALL DIMENSIONS AND TOLERANCES TAKE REFERENCE TO JEDEC MO-229
3. DIMENSION "b" APPLIES TO METALLIZED TERMINAL AND IS MEASURED BETWEEN 0.15MM AND 0.30MM FROM THE TERMINAL TIP. IF THE TERMINAL HAS OPTIONAL RADIUS ON THE OTHER END OF THE TERMINAL, THE DIMENSION B SHOULD NOT BE MEASURED IN THAT RADIUS AREA.

5 Ordering Information

Table 1: Ordering Information

Part Number	Temperature Range	Max Frequency	Note
APS6404L-SQRH-ZR	Tc = -25°C to +85°C	84 MHz	USON-8
APS6404L-SQRH-SN	Tc = -40°C to +85°C	84 MHz	SOP-8
APS6404L-SQRHX-SN	Tc = -40°C to +105°C	84 MHz	SOP-8

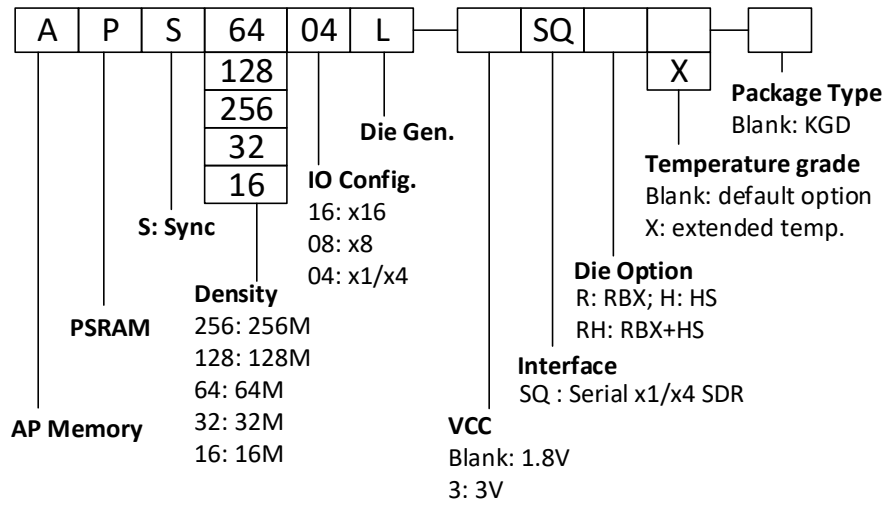

6 Signal Table

All signals are listed in Table 2.

Table 2: Signals Table

Symbol	Type	SPI Mode Function		QPI Mode Function	Comments
VDD	Power	Core supply 1.8V			
VSS	Ground	Core supply ground			
CE#	Input	Chip select, active low. When CE#=1, chip is in standby state			
CLK	Input	Clock Signal			
SI/SIO[0]	IO	Serial Input	IO[0]*	IO[0]	
SO/SIO[1]	IO	Serial Output	IO[1]*	IO[1]	
SIO[2]	IO	--	IO[2]*	IO[2]	
SIO[3]	IO	--	IO[3]*	IO[3]	

Note *: SPI Quad mode

7 Power-Up Initialization

SPI/QPI products include an on-chip voltage sensor used to start the self-initialization process. When VDD reaches a stable level at or above minimum VDD, the device will require 150 μ s and user-issued RESET Operation (see section 12) to complete its self-initialization process. From the beginning of power ramp to the end of the 150 μ s period, CLK should remain LOW, CE# should remain HIGH (track VDD within 200mV) and SI/SO/SIO[3:0] should remain LOW.

After the 150 μ s period the device is ready for normal operation.

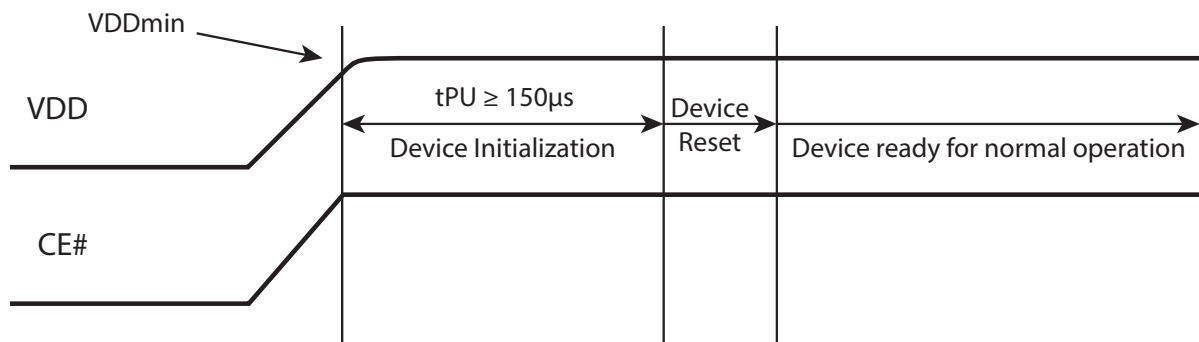

Figure 1. Power-Up Initialization Timing

8 Interface Description

8.1 Address Space

SPI/QPI PSRAM device is byte-addressable. 64M device is addressed with A[22:0].

8.2 Page Size

Page size is 1K (CA[9:0]). The device operates in a linear bursting address sequence that crosses page boundary in a continuous manner. Note however that burst operations which cross page boundary have a lower max input clock frequency limit of 84MHz, and it can cross page boundary one time only in a burst.

8.3 Drive Strength

The device powers up in 50Ω.

8.4 Power-on Status

The device powers up in SPI Mode. It is required to have CE# high before beginning any operations.

8.5 Command/Address Latching Truth Table

The device recognizes the following commands specified by the various input methods.

Command	Code	SPI Mode (QE=0)					QPI Mode (QE=1)				
		Cmd	Addr	Wait Cycle	DIO	Max Freq.	Cmd	Addr	Wait Cycle	DIO	Max Freq.
Read	'h03	S	S	0	S	33	N/A				
Fast Read	'h0B	S	S	8	S	84	Q	Q	4	Q	66
Fast Read Quad	'hEB	S	Q	6	Q	84	Q	Q	6	Q	84
Write	'h02	S	S	0	S	84	Q	Q	0	Q	84
Quad Write	'h38	S	Q	0	Q	84	same as 'h02				
Enter Quad Mode	'h35	S	-	-	-	84	N/A				
Exit Quad Mode	'hF5	N/A					Q	-	-	-	84
Reset Enable	'h66	S	-	-	-	84	Q	-	-	-	84
Reset	'h99	S	-	-	-	84	Q	-	-	-	84
Half Sleep Entry	'hC0	S	-	-	-	84	N/A				
Read ID	'h9F	S	S	0	S	33	N/A				
Remark: S = Serial IO, Q = Quad IO											

8.6 Command Termination

All Reads & Writes must be completed by raising CE# high immediately afterwards in order to terminate the active command and set the device into standby. Not doing so will block internal refresh operations and cause memory failure.

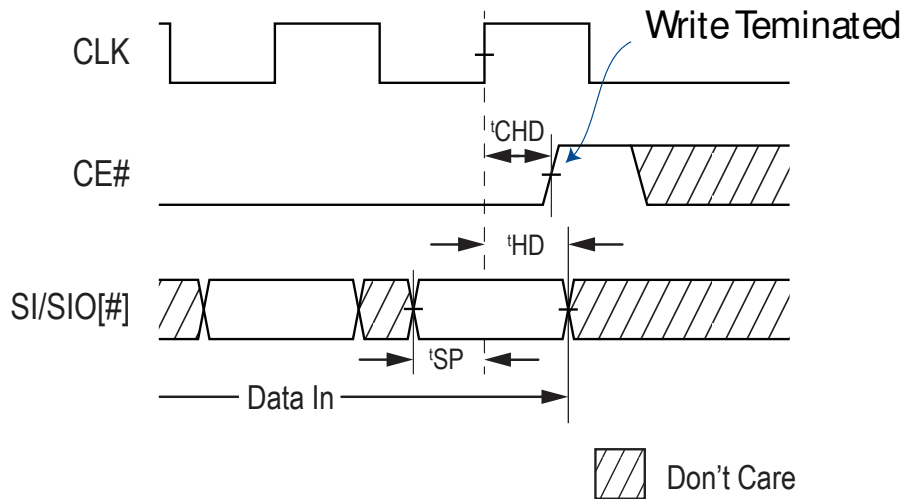

Figure 2: Write Command Termination

For a memory controller to correctly latch the last piece of data prior to read termination, it is recommended to provide a longer CE# hold time ($t_{CHD} > t_{ACLK} + t_{CLK}$) for a sufficient data window.

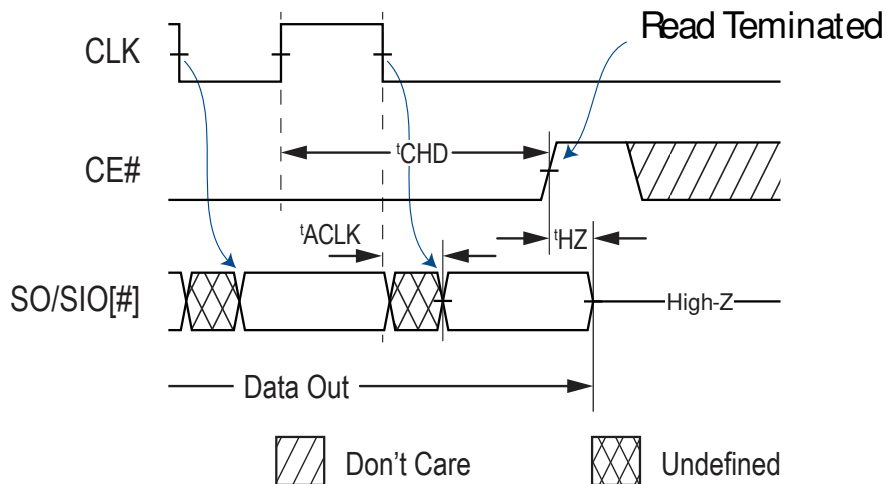

Figure 3: Read Command Termination

9 Half Sleep mode Operation

Half Sleep Mode is a feature which puts the device in an ultra-low power state, while the stored data is retained. Half Sleep Mode Entry can be entered by issuing a command 'hC0 in SPI modes. CE# going high initiates the Half Sleep mode and must be maintained for the minimum duration of t_{HS} . The Half Sleep Entry command sequences are shown below.

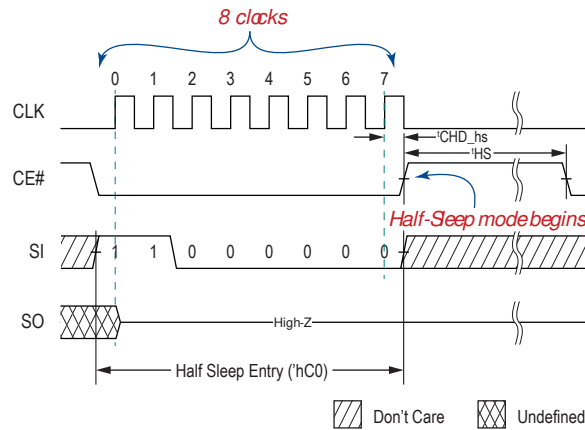

Figure 4: SPI Half Sleep Entry 'hC0, SPI only command.

Half Sleep Exit is initiated by a low pulsed CE#. Afterwards, CE# can be held high with or without clock toggling until the first operation begins (observing minimum t_{XHS}).

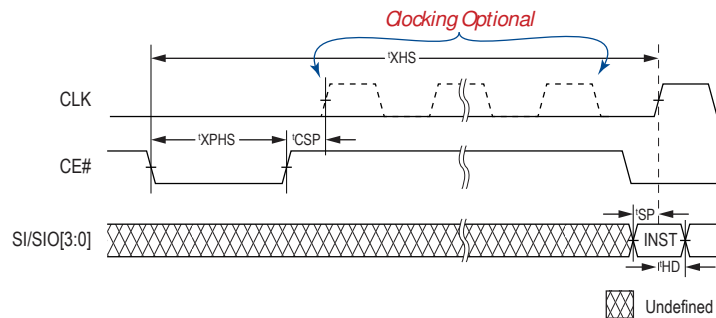

Figure 5: Half Sleep Exit

10 SPI Mode Operations

The device powers up into SPI mode by default but can also be switched into QPI mode.

10.1 SPI Read Operations

For all reads, data will be available t^1_{ACLK} after the falling edge of CLK.

SPI Reads can be done in three ways:

1. 'h03: Serial CMD, Serial Addr/IO, slow frequency.
2. 'h0B: Serial CMD, Serial Addr/IO, fast frequency.
3. 'hEB: Serial CMD, Quad Addr/IO, fast frequency.

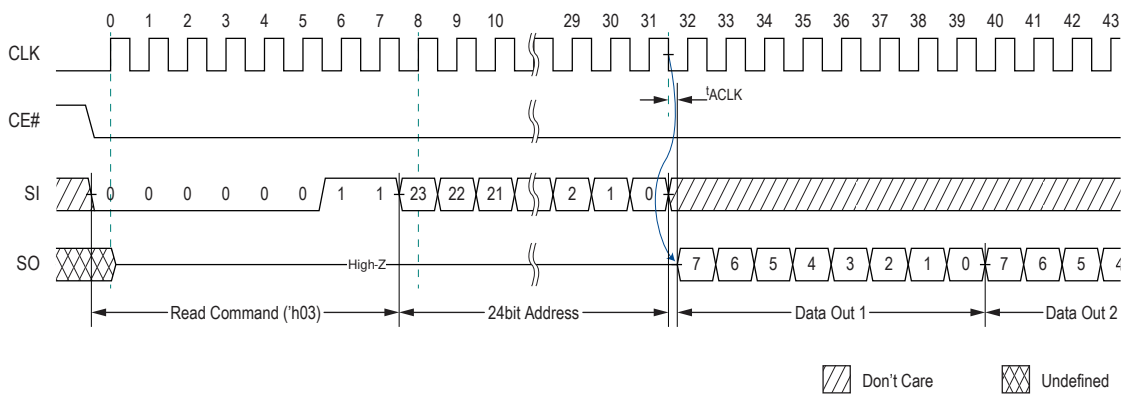

Figure 6: SPI Read 'h03 (max freq 33MHz)

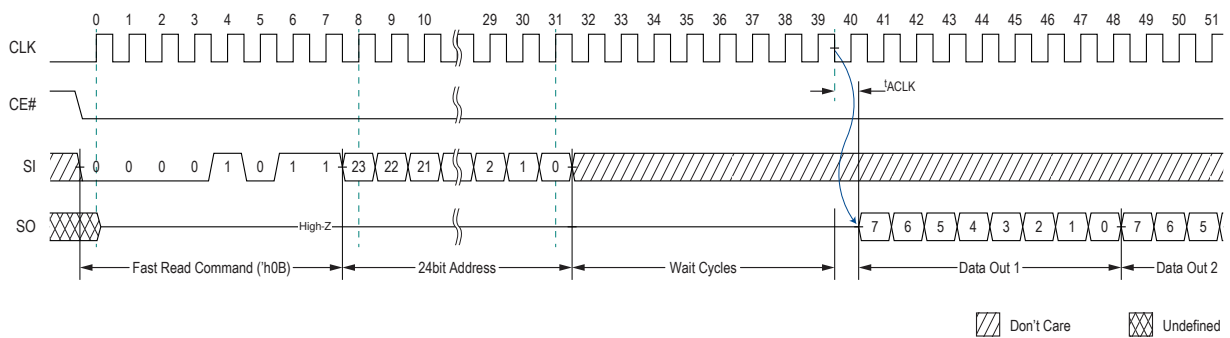

Figure 7: SPI Fast Read 'h0B (max freq 84 MHz)

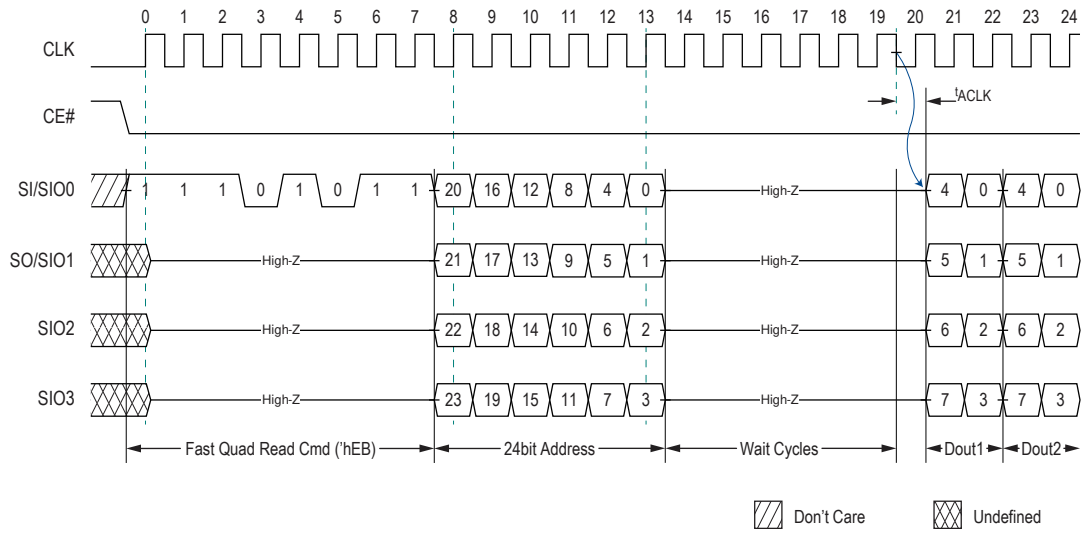

Figure 8: SPI Fast Quad Read 'hEB (max freq 84 MHz)

10.2 SPI Write Operations

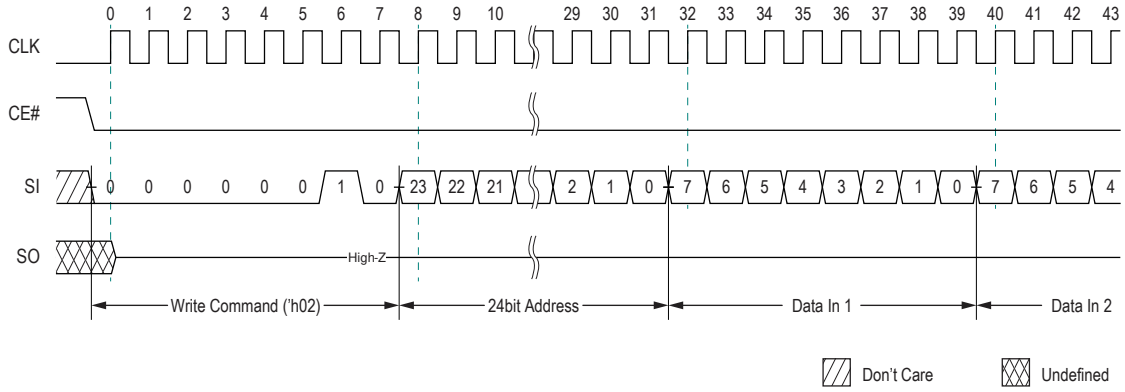

Figure 9: SPI Write 'h02

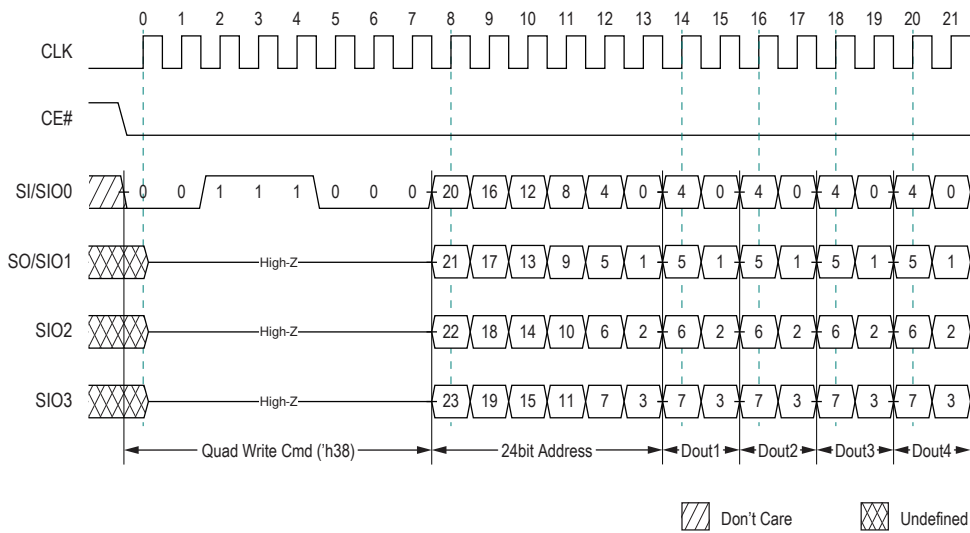

Figure 10: SPI Quad Write 'h38

10.3 SPI Quad Mode Enable Operation

This command switches the device into quad IO mode.

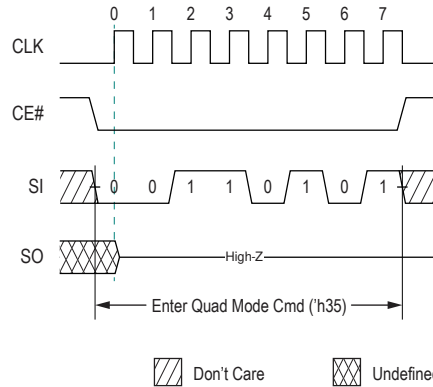

Figure 11: Quad Mode Enable 'h35 (available only in SPI mode)

10.4 SPI Read ID Operation

This command is similar to Fast Read, but without the wait cycles and the device outputs EID value instead of data.

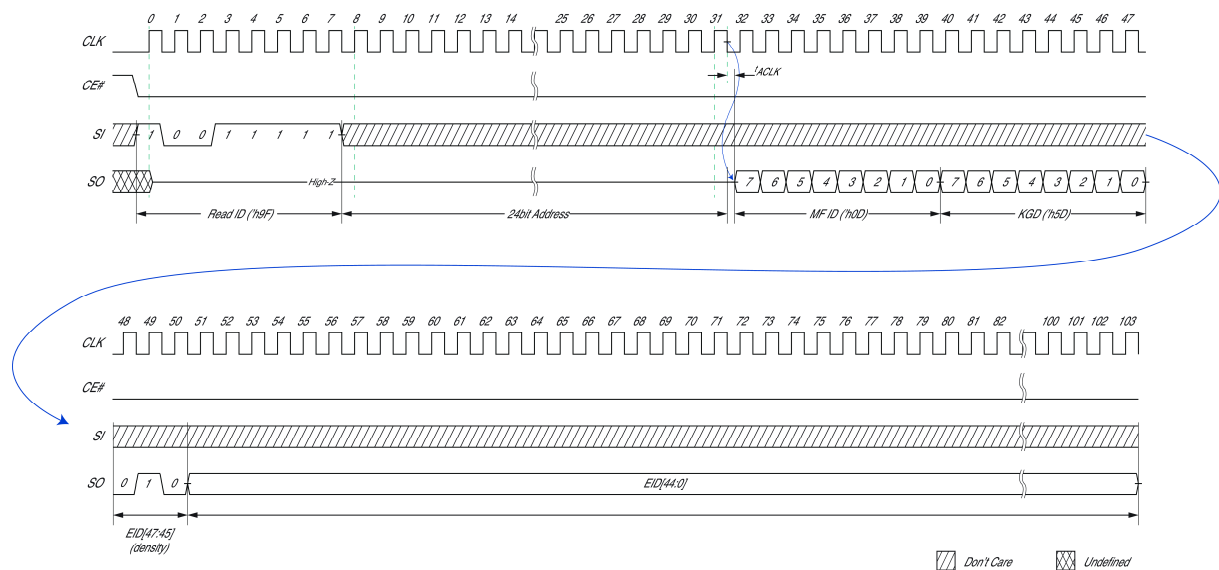

Figure 12: SPI Read ID 'h9F (available only in SPI mode)

Table 3: Known Good Die (KGD)

KGD[7:0]	Known Good Die
'b0101_0101	FAIL
'b0101_1101	PASS

*Note: Default is FAIL die, and only marked PASS after all tests passed.

11 QPI Mode Operations

11.1 QPI Read Operation

For all reads, data will be available $t^{\dagger}\text{ACLK}$ after the falling edge of CLK.

QPI Reads can be done in one of two ways:

1. 'h0B: Quad CMD, Quad Addr/IO, slow frequency
2. 'hEB: Quad CMD, Quad Addr/IO, fast frequency

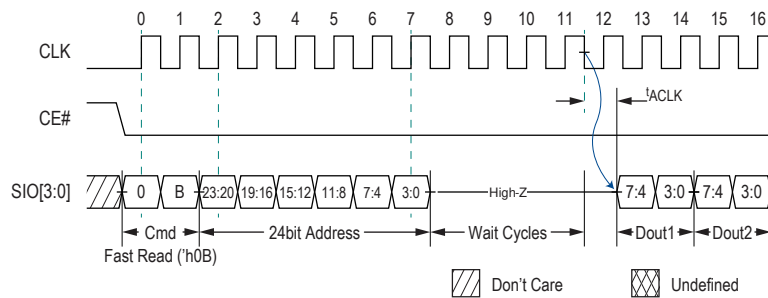

Figure 13: QPI Fast Read 'h0B (max freq 66 MHz)

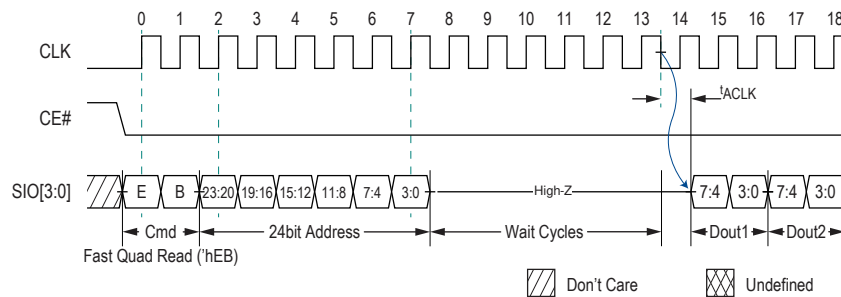

Figure 14: QPI Fast Quad Read 'hEB (max freq 84 MHz)

11.2 QPI Write Operation(s)

QPI write command can be input as 'h02 or 'h38.

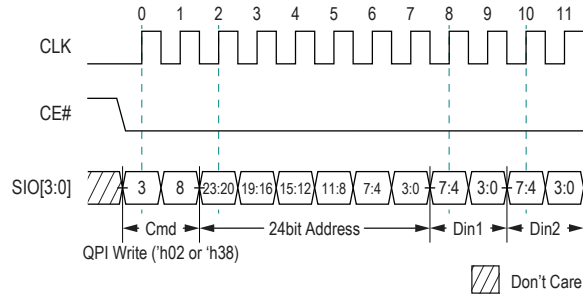

Figure 15: QPI Write 'h02 or 'h38

11.3 QPI Quad Mode Exit operation

This command will switch the device back into serial IO mode.

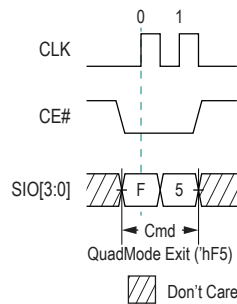

Figure 16: Quad Mode Exit 'hF5 (only available in QPI mode)

12 Reset Operation

The Reset operation is used as a system (software) reset that puts the device in SPI standby mode which is also the default mode after power-up. This operation consists of two commands: Reset-Enable (RSTEN) and Reset (RST).

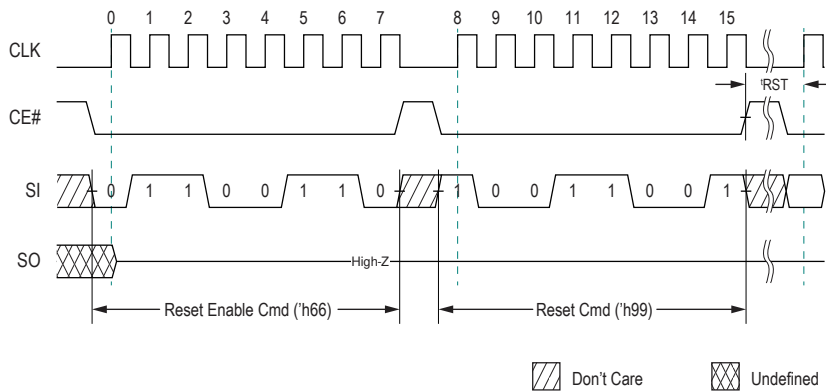

Figure 17: SPI Reset

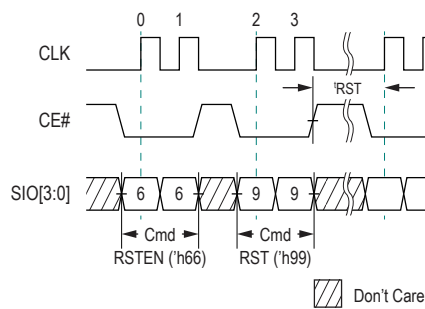

Figure 18: QPI Reset

Reset command has to immediately follow the Reset-Enable command in order for the reset operation to take effect. Any command other than the Reset command after the Reset-Enable command will cause the device to exit Reset-Enable state and abandon reset operation.

13 Input/Output Timing

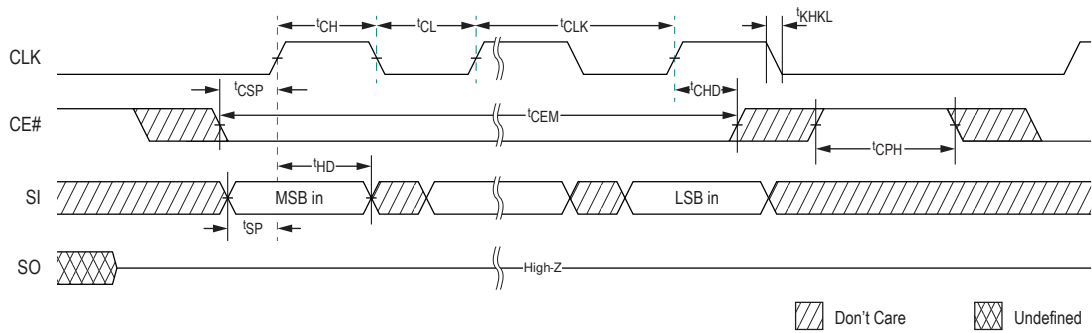

Figure 19: Input Timing

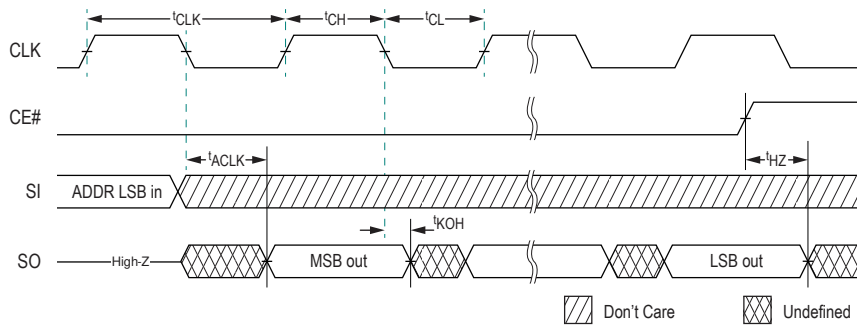

Figure 20: Output Timing

14 Electrical Specifications:

14.1 Absolute Maximum Ratings

Table 4: Absolute Maximum Ratings

Parameter	Symbol	Rating	Unit	Notes
Voltage to any ball except V_{DD} relative to V_{SS}	VT	-0.4 to $V_{DD}+0.4$	V	
Voltage on V_{DD} supply relative to V_{SS}	V_{DD}	-0.4 to +2.45	V	
Storage Temperature	T_{STG}	-55 to +150	°C	1

Notes 1: Storage temperature refers to the case surface temperature on the center/top side of the PSRAM.

Caution:

Exposing the device to stress above those listed in Absolute Maximum Ratings could cause permanent damage. The device is not meant to be operated under conditions outside the limits described in the operational section of this specification. Exposure to Absolute Maximum Rating conditions for extended periods may affect device reliability.

14.2 Pin Capacitance

Table 5: Package Pin Capacitance

Parameter	Symbol	Min	Max	Unit	Notes
Input Pin Capacitance	CIN		6	pF	VIN=0V
Output Pin Capacitance	COUT		8	pF	VOUT=0V

Note 1: spec'd at 25°C.

Table 6: Bare Die Pin Capacitance

Parameter	Symbol	Min	Max	Unit	Notes
Input Pin Capacitance	CIN		2	pF	VIN=0V
Output Pin Capacitance	COUT		3	pF	VOUT=0V

Note 1: spec'd at 25°C.

Table 7: Load Capacitance

Parameter	Symbol	Min	Max	Unit	Notes
Load Capacitance	C_L		15	pF	

Note 1: System C_L for the use of package

14.3 Decoupling Capacitor Requirement

System designers need to take care of power integrity considering voltage regulator response and the memory peak currents/usage modes.

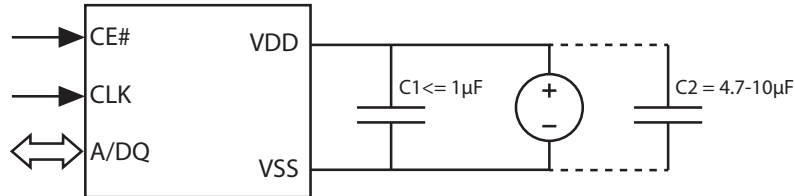

14.3.1 Low ESR cap C1:

It is recommended to place a low ESR decoupling capacitor of $\leq 1\mu\text{F}$ close to the device to absorb transient peaks.

14.3.2 Large cap C2:

During Half-sleep modes even though half-sleep average currents are very small (less than $100\mu\text{A}$), device will internally have low duty cycle burst refresh for an extended period of time of a few tens of microseconds. These refresh current peaks are large. During this period if the system regulator cannot supply large peaks for several microseconds, it is important to place a $4.7\mu\text{F}$ - $10\mu\text{F}$ cap to take care of burst refresh currents and replenish the charge before next burst of refreshes.

14.4 Operating Conditions

Table 8: Operating Characteristics

Parameter	Min	Max	Unit	Notes
Operating Temperature (extended)	-40	105	°C	1
Operating Temperature (standard)	-40(-25*)	85	°C	*varies by package type

Note 1: spec'd temp range of -40 to 105°C is only characterized; test condition will be -32 to 105°C.

14.5 DC Characteristics

Table 9: DC Characteristics

Symbol	Parameter	Min	Max	Unit	Notes
V _{DD}	Supply Voltage	1.62	1.98	V	
V _{IH}	Input high voltage	V _{DD} -0.4	V _{DD} +0.2	V	
V _{IL}	Input low voltage	-0.2	0.4	V	
V _{OH}	Output high voltage (I _{OH} =-0.2mA)	0.8 V _{DD}		V	
V _{OL}	Output low voltage (I _{OL} =+0.2mA)		0.2 V _{DD}	V	
I _{LI}	Input leakage current		1	μA	
I _{LO}	Output leakage current		1	μA	
I _{CC}	Read/Write		7	mA	1,2
ISB _{EXT}	Standby current (extended temp)		300	μA	3
ISB _{STD}	Standby current (standard temp)		200	μA	3
ISB _{STDROOM}	Standby current (standard room temp)		100	μA	3,4
ISB _{STD_HS}	Half Sleep current (standard room temp)		30	μA	3,5

- Note
- 1: Output load current not included.
 - 2: Typical I_{CC} 5.0mA at 84MHz.
 - 3: Standby current is measured when CLK is in DC low state.
 - 4: Typical ISB_{STDROOM} is 66μA.
 - 5: Typical ISB_{STD_HS} is 20uA.

14.6 AC Characteristics

Table 10: READ/WRITE Timing

Symbol	Parameter	Min	Max	Unit	Notes
t_{CLK}	CLK period - SPI Read ('h03)	30.3		ns	33MHz
	CLK period - QPI Read ('h0B)	15.1			66MHz
	CLK period - all other operations	7			84MHz ^{*1,2}
t_{CH}/t_{CL}	Clock high/low width	0.45	0.55	$t_{CLK}(\text{min})$	
t_{KHKL}	CLK rise or fall time		1.5	ns	3
t_{CPH}	CE# HIGH between subsequent burst operations	18		ns	
t_{CEM}	CE# low pulse width		4	μs	Extended grade
			8		Standard grade
t_{CSP}	CE# setup time to CLK rising edge PKG	2.5		ns	
t_{CHD}	CE# hold time from CLK rising edge PKG	3.0		ns	2
t_{CHD_HS}	CE# hold time from CLK rising edge for Half Sleep Entry command	6		ns	
t_{SP}	Setup time to active CLK edge	2		ns	
t_{HD}	Hold time from active CLK edge	2		ns	
t_{HZ}	Chip disable to DQ output high-Z		5.5	ns	
t_{ACLK}	CLK to output delay	2	5.5	ns	
t_{KOH}	Data hold time from clock falling edge	1.5		ns	
t_{HS}	Minimum Half Sleep duration	4		μs	
t_{XHS}	Half Sleep Exit CE# low to CLK setup time	150		μs	
t_{XPHS}	Half Sleep Exit CE# low pulse width	60		ns	
			8	μs	Standard temp
			4	μs	Extended temp
t_{RST}	Time between end of RST CMD to next	50		ns	

Note 1: Frequency limits are therefore:
84MHz max when burst commands cross page boundary

2: System max C_L 15pF for the use of package.

3: Measured from 20% to 80% of VDD