

# 1. SPECIFICATION

AR-1332DA-21W

ITEMS.		SPECIFICATIONS
01	Type	Dynamic 13mm receiver unit
02	Sensitivity (S.P.L)	115dB $\pm$ 3 dB at 1kHz 180mV with IEC 318 coupler
03	Impedance.	32 Ohm $\pm$ 15% at 1KHz
04	Magnet Field Intensity.	Axial – dB , Radial –dB at 1KHz
05	Nominal Input Power	10mW
06	Max. Input Power.	Must be normal at a white noise , 26mW( 900mV ) for 1 minute.
07	Total Harmonics Distortion	Max 5 % at 1K Hz.
08	Operation temperature	-30°C to +70°C
09	Storage temperature	-40°C to +85°C
10	Weight.	1.1g $\pm$ 0.3g

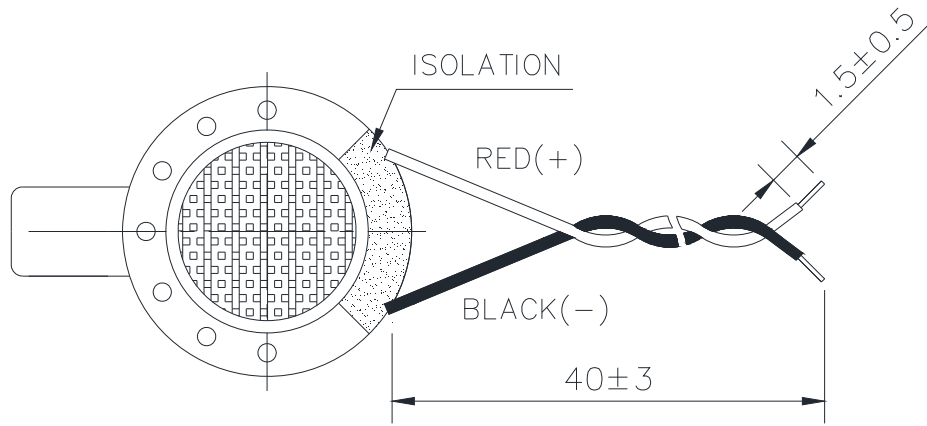

WIRE : UL1571 AWG32

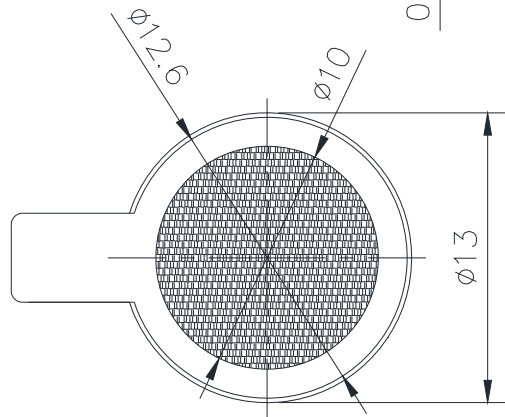
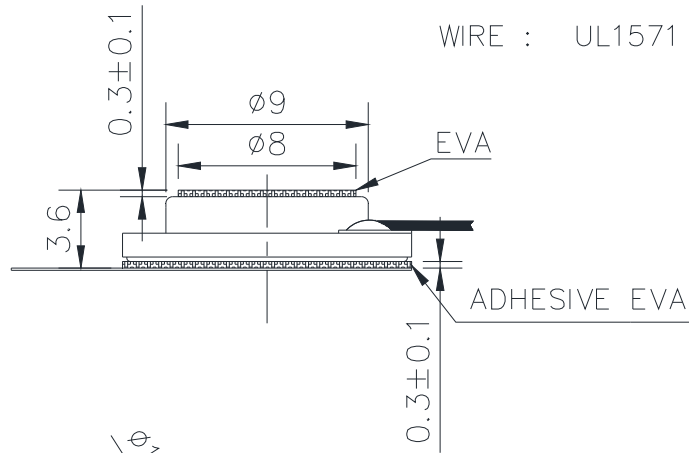

MATERIAL  
 HOUSING : METAL  
 DIAPHRAGM : PEI

TITLE: <i>DYNAMIC RECEIVER</i>		DRAWN: <i>JOHN</i> 01/27/2005	SCALE: 3:1	SHEET: 1 of 1
PART NO. <i>AR-1332DA-21W</i>		DESIGNED: R & D OF AAT	UNITS: mm	
DWG NO. <i>DTR-1085</i>		CHECKED:	TOLERANCE ± 0.2	
		APPROVAL:	UNLESS OTHERWISE SPECIFIED:	
REV		MATERIAL: *****	ONE PLACE DECIMAL ± ***	
			TWO PLACE DECIMAL ± ***	
			THREE PLACE DECIMAL ± ***	

